

Internal distribution code:

- (A) [-] Publication in OJ
- (B) [-] To Chairmen and Members
- (C) [-] To Chairmen
- (D) [X] No distribution

**Datasheet for the decision
of 15 February 2019**

Case Number: T 2007/16 - 3.2.05

Application Number: 03720671.1

Publication Number: 1490236

IPC: B42D15/10

Language of the proceedings: EN

Title of invention:
Optically variable security device

Patent Proprietor:
De La Rue International Limited

Opponent:
Leonhard Kurz Stiftung & Co. KG

Relevant legal provisions:
EPC 1973 Art. 54(1), 56, 100(a), 100(b), 100(c)

Keyword:
Added matter (no)
Sufficiency of disclosure (yes)
Novelty (yes)
Inventive step (no)
Remittal to the first instance (yes)

Catchword:

Objection of insufficient disclosure based on the subject-matter of a dependent claim (see point 5).



Beschwerdekammern
Boards of Appeal
Chambres de recours

Boards of Appeal of the
European Patent Office
Richard-Reitzner-Allee 8
85540 Haar
GERMANY
Tel. +49 (0)89 2399-0
Fax +49 (0)89 2399-4465

Case Number: T 2007/16 - 3.2.05

D E C I S I O N
of Technical Board of Appeal 3.2.05
of 15 February 2019

Appellant: Leonhard Kurz Stiftung & Co. KG
(Opponent) Schwabacher Strasse 482
90763 Fürth (DE)

Representative: Norbert Zinsinger
Louis, Pöhlau, Lohrentz
Patentanwälte
Postfach 30 55
90014 Nürnberg (DE)

Respondent: De La Rue International Limited
(Patent Proprietor) De La Rue House,
Jays Close,
Viables
Basingstoke, Hampshire RG22 4BS (GB)

Representative: Gill Jennings & Every LLP
The Broadgate Tower
20 Primrose Street
London EC2A 2ES (GB)

Decision under appeal: **Decision of the Opposition Division of the
European Patent Office posted on 15 July 2016
rejecting the opposition filed against European
patent No. 1490236 pursuant to Article 101(2)
EPC.**

Composition of the Board:

Chairman M. Poock
Members: O. Randl
 D. Rogers

Summary of Facts and Submissions

- I. The opponent filed an appeal against the decision of the opposition division rejecting the opposition against European patent No. 1 490 236.

The opposition division found neither of the three grounds of opposition under Article 100 a) to c) EPC 1973 to prejudice the maintenance of the patent as granted.

Among the documents cited by the opposition division, the following are relevant for the appeal proceedings:

D1: WO 97/19820 A1;
D2: EP 0 201 323 A2;
D3: CH 689 680 A5;
D4: WO 97/23856 A1;
D5: DE 100 07 916 A1;
D6: JP 2001-315472 A;
D7: EP 0 328 086 A2;
D8: WO 91/06925 A1.

- II. The oral proceedings before the board took place on 15 February 2019.
- III. The appellant (opponent) requested that the decision under appeal be set aside and the patent be revoked.

The respondent (patent proprietor) requested to dismiss the appeal, or alternatively, to set aside the decision under appeal and to maintain the patent upon the basis of one of the first to eleventh Auxiliary Requests, all filed under cover of a letter dated 22 March 2017.

IV. Claims 1, 3 and 14 of the patent (main request) read as follows (the feature references used by the board are indicated in square brackets):

"1. [1-1] A security device [1-2] comprising at least first and second superposed and differentiated diffractive or holographic optically variable effect generating structures (4,4'), [1-3] each having a surface relief microstructure, [1-4] the second optically variable effect generating structure (4') being viewable through the first, wherein [1-5] the first optically variable effect generating structure includes a discontinuous metallic layer (5A,5B) characterized in that [1-6] a dye or pigment is provided in or between layer(s) of the optically variable effect generating structures (4,4') and wherein [1-7] the structures generate a visually integrated image."

"3. A device according to any of the preceding claims, wherein the first and second optically variable effect generating structures (4,4') generate orthogonal holographic images, typically originated by classical holography."

"14. [14-1] A method of manufacturing a security device, the method comprising [14-2] providing at least first and second superposed and differentiated diffractive or holographic optically variable effect generating structures (4,4'), [14-3] each having a surface relief microstructure, whereby [14-4] the second optically variable effect generating structure (4') is viewable through the first, wherein [14-5] the first optically variable effect generating structure includes a discontinuous metallic layer (5A,5B) characterized in that [14-6] a dye or

pigment is provided in or between layer(s) of the optically variable effect generating structures (4,4') and wherein [14-7] the structures generate a visually integrated image."

V. The appellant argued as follows:

(a) Inadmissible extension

Claims 1 and 14 extend beyond the content of the original application because both the differentiation referred to in features 1-2 and 14-2 and the generation of a visually integrated image (features 1-7 and 14-7) have no basis in the original application.

(b) Insufficiency of disclosure

Those skilled in the art would not know how to obtain the object of dependent claim 3 because they would not know how to obtain orthogonal holographic images. Therefore, the subject-matter of claim 1 (which encompasses the object of claim 3) is not sufficiently disclosed over the whole scope of the claim.

(c) Novelty

Claims 1 and 14 lack novelty over the disclosure of documents D1, D3, D4, D5, and D6.

(i) Novelty over document D1

Contrary to the opinion of the opposition division, feature 1-6 is disclosed in document D1. In the embodiment according to Fig. 12, it is possible to

construe the layered structure made up of the lacquer layer 48 and the metallic layer 9 as the "first structure" and the layered structure comprising the metallic layer 8 and the adhesive layer 12 as the "second structure". Document D1 explicitly refers to document D2 (see page 14, lines 4 to 5), which discloses the use of dye (see page 20, lines 5 to 21, and claim 10).

Feature 1-7 is also disclosed: when the individual OVM exposes variable colours as a function of the angle of observation, the overall impression of the device changes as well. Each OVM produces an image, but the two OVMs together generate an integrated image. The appellant referred to the embodiment of Fig. 13, which comprises kinematic motifs 52 that qualify as OVMs (see page 15, lines 8 and following). Additional OVMs in the shape of letters 53 (see page 15, lines 21 to 23) are visible through the gaps 49. They produce a rainbow effect: there is no direction where the letters are invisible. Paragraph [0019] of the patent corroborates this reading of the claim. The interpretation of the claim must not be based on other documents, such as document D7.

That Figs. 12 and 13 refer to the same embodiment is clear from page 15, line 8 etc. Fig. 12 shows a longitudinal cross-section of the security device of Fig. 13.

Paragraph [0012] of document D1 refers to a completely different embodiment and should not be used when the embodiment of Figs. 12 and 13 is examined.

(ii) Novelty over document D3

The subject-matter of claims 1 and 14 is not new over the disclosure of document D3. This document teaches to provide printed images between the outer protective layer 2" and the intermediate layer 17 (see Fig. 4, claim 8, col. 5, lines 38 to 44, and the passage extending from col. 5, line 63 to col. 6, line 2). Moreover, document D3 discloses that the protective layer 2, which according to Fig. 4 is formed by the outer protective layer 2' and the intermediate layer 17, is to be dyed in at least two adjacent regions (see claim 12 and col.5, lines 33 to 38). Both variants encompassed in feature 1-6 are disclosed when the set of layers 2', 14, 14', the security element 3 and the relief structure 21 are understood to form the first structure and the ensemble formed by protective lacquer 20, the diffraction element 5, the indicia 10, the embossed layer 19 and possibly the substrate 1 is understood to form the second structure. The first variant is realised when the intermediate layer 17, which is located between the elements, is dyed. The second variant is obtained when the layer 2' is dyed.

(iii) Novelty over document D4

Contrary to the opinion of the opposition division, document D4 discloses features 1-4 and 1-7. It is possible to consider the first element 13 to be the first OVM and the second element 12 the second OVM. The partial layer 7 constitutes the layer with pigments between those elements. The embodiment of Fig. 2 is designed to be visible through a windscreen. The opaque layer 8 makes it impossible

to convey information through the backside. Thus, the second structure 12 is visible through the first structure 13. The embossed lacquer layer 5 of the first structure is transparent and covered with a hologram over its entire surface (see page 4, lines 7 to 9). However, the metal layer does not entirely cover this hologram, so there are gaps through which the metallic layer 10 of the second structure 12 is visible (see col. 4, line 34 to col. 5, line 5, and col. 2, lines 25 to 38). It is apparent from Fig. 3 and Fig. 1 that the second structure 12 has a greater surface than the first structure 13 and completely covers the latter. Thus, the metallised holographic structure of the lacquer layer 10 is visible through the gaps in the lacquer layer 5 of the first structure.

(iv) Novelty over document D5

The opposition division failed to realise that document D5 discloses feature 1-6. Claim 10 of document D5 discloses that a printed image is part of the security element. It is not explicitly disclosed between which layers it is provided, but irrespective of the precise choice, one of the options expressed by features 1-6 and 14-6 would necessarily be chosen.

(v) Novelty over document D6

The finding of the opposition division that document D6 does not disclose feature 1-5 and that, although feature 1-6 and the combination of features 1-4 and 1-7 are disclosed as such, they are not disclosed in combination, is wrong. Fig. 9 discloses a metallic layer that does not cover the

entire surface of the second structure (see also paragraph [0043]). The explanations regarding the dyed lacquer layer in paragraph [0078] refer to the preceding disclosure in a very general way and do not constitute a distinct embodiment. Thus, all the features are disclosed in combination.

(d) Inventive step

The subject-matter of claims 1 and 14 does not involve an inventive step. The appellant expressed its agreement with the provisional opinion expressed in the communication of the board, according to which feature 1-6 would be obvious for the skilled person starting from the disclosure of document D1 and considering the teaching of document D8 to solve the objective technical problem. The skilled person would envisage combining the teaching of these documents because both deal with security elements comprising diffractive structures. It is a common feature of all the embodiments shown in document D8 that printed ink images are provided between the embossed layer and the reflective layer (see page 9, lines 13 to 15). There is no reason why the skilled person would not make use of this teaching and introduce ink to increase the difficulty of counterfeiting.

(e) Remittal to the department of first instance

The appellant declared that it did not object to a remittal of the case.

VI. The respondent argued as follows:

(a) Inadmissible extension

There is no inadmissible extension of subject-matter. The original application, on page 2, lines 33 to 36, discloses that there are differentiated OVMS. A reading of this passage in the context of the rest of the description (see page 3, lines 17 to 20, page 4, lines 13 to 16, original claim 21, page 6, line 20 to page 7, line 27, and all the figures) must be considered to provide an appropriate basis for this feature. Feature 1-7 has a basis on page 19. Two passages of the description (page 3, lines 34 to 37, and page 4, lines 1 to 4) confirm that the inventive principle is shared by all the embodiments.

(b) Insufficiency of disclosure

The patent does not infringe Article 83 EPC. Claim 3 is provided with an enabling disclosure on page 13, line 18, to page 14, line 2. The invention concerns two separate and superposed microstructures. In view of this disclosure, those skilled in the art would be able to freely configure the orientation of these superposed structures to achieve the orthogonal imagery of claim 3.

(c) Patentability

Claims 1 and 14 are both novel and inventive over the cited state of the art.

(i) Novelty over document D1

This document discloses neither a pigment (feature 1-6) nor two structures which generate a visually integrated image (feature 1-7).

An integrated image within the meaning of claim 1 is more than just an overall impression produced by the device. Multiple OVMS do not always generate integrated images. Document D7 (in col. 12, lines 12 and following, and Fig. 11) discloses an example in which two different images can be seen at different angles. It also mentions the problems of crosstalk between multiple holograms. Document D1 also envisages the case of separate images (see page 12, lines 5 to 8). Fig. 12, while being a different embodiment, does not explicitly state whether there is one single image or not. This is not sufficient to anticipate the feature of claim 1. Fig. 13 is a schematic drawing, as can be seen from the fact that the very thin layer 3 (thickness: 100-200 micrometres, see page 13, lines 15 and 16) is drawn as if it were quite thick. This makes it clear that features regarding when the images are visible cannot be extracted from this drawing. Fig. 12 shows gaps in the upper structure, but some of the gaps are in neutral areas where there is no relief structure at all. Thus, it cannot be said that document D1 directly and unambiguously discloses feature 1-7. Moreover, document D1 does not disclose that the colours of the letters 53 are visible over all viewing angles.

Fig. 9 shows a structure that is very similar to Fig. 12. Document D1 clearly acknowledges the fact

that the images generated by these relief structures are not visible at all angles.

(ii) Novelty over document D3

It is not disclosed in document D3 that the diffraction structure 5 overlaps with either the security element 3 or the relief structure 21. The side view offered in Fig. 4 does not disclose whether these features are laterally arranged. Thus, feature 1-4 is not disclosed. Document D3 also fails to disclose that the first OVM includes a metallic layer (feature 1-5). Feature 1-6 is not disclosed either.

(iii) Novelty over document D4

Document D4 does not directly and unambiguously teach the location of the second holographic structure 10. The logic of the appellant's argument is flawed. The document is silent with regards to the positioning of the stamped hologram. It is entirely possible that the second hologram stamped in the second element 12 is intended to be visible. The lack of precision of document D4 is enough to render the claims novel over document D4. Also, there is no disclosure in this document that the second hologram of the second element 12 carries an OVM different from that of the first element.

(iv) Novelty over document D5

While document D5 discloses embodiments comprising relief structures on opposing sides of the security element, it is not disclosed whether the relief structures are different, as required by the

claims. Regarding claim 10 of document D5, document D5 clearly teaches that the inks can be provided as an overprinting on one side of the security element (see claim 9). It is incorrect to consider that claim 10 teaches that ink should be incorporated into the structure of the security element.

(v) Novelty over document D6

In Fig. 9, the metal layer is continuous with respect to the hologram to which it is applied. Thus, the layer is a continuous metal layer of the type described in paragraph [0067]. Further, since this hologram of Fig. 9 is opaque, the second structure is not visible through the first hologram but visible around it.

(d) Inventive step

The subject-matter of claims 1 and 14 does involve an inventive step over the combination of documents D1 and D8.

Document D8 relates to single holograms. The skilled person trying to improve a superposed arrangement of OVMs would not expect to find an answer in this document. The main concern of document D8 is preventing fraud by reuse (see page 3, lines 20 to 24). Thus, the skilled person would understand that the teaching of document D8 is not to make the device more difficult to counterfeit but to prevent fraud by reuse. The overall aim of the document is different from the objective technical problem. There is no incentive for the skilled person to consult this

document and to integrate its teaching into document D1. Document D8 only discloses the use of inks in relation to holograms and diffractive devices embossed over large contiguous areas. As can be seen from page 10, lines 10 to 21, document D8 teaches to provide non-diffractive areas generating a second, static image (see page 8, lines 3 to 7, and claim 1). It is not particularly concerned with introducing dyes or pigments. Document D8 sees the printed ink as a means to pattern the otherwise large and contiguous holograms by concealing the optically variable effect. Those skilled in the art would see that there are already optically inactive areas (see document D1, page 14, lines 17 to 21). If they were to apply the teaching of document D8 to document D1, they would do so by adapting the optically inactive regions that document D1 already provides rather than seeking and incorporating additional means of producing optically inactive areas.

(e) Remittal to the department of first instance

When the board stated that it found claim 1 of the main request not to be inventive and that it envisaged a remittal to the department of first instance, the respondent expressed its approval of this course of action.

Reasons for the Decision

1. Applicable law

The application on which the patent is based was filed on 3 April 2003. In application of Article 7 of the Act revising the EPC of 29 November 2000 (Special edition No. 4, OJ EPO, 217) and the Decision of the Administrative Council of 28 June 2001 on the transitional provisions under Article 7 of the Act revising the EPC of 29 November 2000 (Special edition No. 4, OJ EPO, 219), Articles 54, 56, 100, and 111 EPC 1973 and Article 123 EPC [2000] apply in the present case.

2. Terminology

Having to deal with a great number of references to the original application, the board introduces the following abbreviation: "p.N/L-M", N, L and M being integer numbers, refers to page N, lines L to M. For instance, "p.4/13-16" is a reference to page 4, lines 13 to 16; "p.3/19" refers to line 19 of page 3.

The board understands the expression "optically variable effect generating structures" to convey the same meaning as the expression "image generating optical variable microstructures", which the patent abbreviates as OVM. The board, therefore, uses the same abbreviation for both expressions.

3. Claim interpretation

3.1 Structural requirements for the OVM

A security device according to claim 1 or manufactured with a method according to claim 14, comprises at least two superposed OVMs (features 1-2 and 14-2). Each OVM comprises a surface relief microstructure (features 1-3 and 14-3), but at least one of them (the "first" OVM referred to in features 1-2 and 1-5 (14-2 and 14-5)) has to be a composite unit made up of several elements because it must comprise a discontinuous metallic layer (features 1-5 and 14-5). That layer is at least partially transparent to light in the visible spectrum so that the second (underlying) OVM is viewable through the first (features 1-4 and 14-4). Finally, dye or pigment is provided in at least one layer or, if there are several layers, possibly also between the layers (features 1-6 and 14-6) of each OVM (see point 3.4).

Only elements that actually contribute to the generation of optically variable effects (such as the surface relief microstructures and the corresponding reflection layers etc.) can be said to be part of the OVM. Mere protection or support layers are not part of the OVM within the meaning of claims 1 and 14.

3.2 Features 1-2 and 14-2: "differentiated"

Feature 1-2 refers to "differentiated" diffractive or holographic OVMs. The patent does not contain a definition of what exactly is meant by "differentiated".

The Oxford English Dictionary (OED) defines the verb "differentiate" in its transitive form as "to cause

(something) to be ... distinguished (from something else); to cause or constitute a difference between". Thus, two objects may be said to be "differentiated" if they can be distinguished from each other.

This understanding is compatible with the use of the verb in the patent and in the original application. For instance, paragraph [0056] of the patent discloses:

"Two possible thread structures are shown in Fig. 13 and Fig. 14, differentiated by the fact that in the former (Fig. 13) the photopolymer's PET support layer 32 is retained as one of the outward facing layers whilst in the latter (Fig. 14) the photopolymer 30 provides one of the outward facing layers." (Underlining by the board.)

The differentiation mentioned in this passage clearly refers to structural differences resulting in that the thread structures can be distinguished from each other.

3.3 Features 1-3 and 14-3: "surface relief microstructure"

The expression "surface relief microstructure" is not defined in the opposed patent. The skilled person in the field of security devices would be familiar with holograms. One type of hologram is obtained by surface relief grating, i.e. a periodic variation of thickness in a material of constant refractive index. Such holograms reflect light. Surface relief microstructures are understood to correspond to this kind of holograms.

Surface relief microstructures are to be distinguished from volume (or Bragg) holograms. In such holograms the thickness of the recording material is much larger than

the light wavelength used for recording. Diffraction of light from the hologram occurs under the conditions of Bragg diffraction (wavelength, wave shape). This is obtained by periodic variation of the refractive index (index modulation). Volume holograms usually operate in transmission.

3.4 Features 1-6 and 14-6

According to these features, a dye or pigment is provided "in or between layer(s) of the optically variable effect generating structures". This feature is somewhat ambiguous and in need of interpretation.

First, does the feature refer to layers of OVMS or layered OVMS? The overall disclosure of the patent (see, for instance, paragraph [0047]) strongly suggests that layered OVMS are meant. Also, if layers of OVMS were meant, the feature would have been drafted without the definite article ("in or between layer(s) of ~~the~~ optically variable effect generating structures").

Second, the expression "in or between layer(s)" is understood to mean "in one layer or in several layers or between layers".

Accordingly, the variant 'in' may correspond to an OVM comprising only one layer, whereas the variant 'between' requires the OVM to have at least two layers.

Finally, the reference to the plural ("structures") makes clear that claim 1 requires dye or pigment to be provided in all the OVMS referred to in the preceding claim features. A security device in which only the first or the second OVM contains dye or pigment is not encompassed by the claims.

3.5 Features 1-7 and 14-7: "visually integrated image"

The patent does not contain any definition of what is meant by the expression "visually integrated image". The OED defines the adjective "integrated" as "combined into a whole; united; undivided" and "uniting in one system several constituents previously regarded as separate". Considering this general meaning of the adjective, the board understands the expression "visually integrated image" to designate an image that appears united and undivided to an onlooker. Accordingly, claim 1 does not encompass devices in which the diffractive or holographic effects are only ever visible separately (at distinct viewing angles).

4. Inadmissible extension (Article 100 c) EPC 1973)

4.1 Features 1-2 and 14-2

According to these features, the interpretation of which is given in point 3.2 above, the security feature comprises at least a first and second superposed and differentiated diffractive or holographic OVMs.

According to the opposition division, this feature is disclosed at p.2/34-35 of the original application:

"The present invention increases the visual sophistication, security and differentiation of the diffractive or holographic imagery ..."

The opposition division pointed out that throughout the whole application only structures different from each other were disclosed (referring in particular to Fig. 1,

p.3/19, p.4/13-16, p.6/20 to p.7/27, p.11/26-29, p.12/9-11, p.12/33-36, p.13/6, p.19/7-9, and original claim 5), and that claim 21 explained that the structures were derived from different processes.

The disclosure of p.2/33-36 refers to the differentiation of the imagery as a whole rather than to the differentiation of the OVMS. Also, p.3/19 does not establish that the structures are different from each other.

The passage p.4/13-16 ("It is preferable that two distinctly different origination technologies, for example e-beam lithography and two-step rainbow holography are used to create OVM 1 and OVM 2.") is more relevant because the skilled person would understand that the use of two different technologies, which as such is cumbersome, is preferable precisely because it allows obtaining structures different from each other. It may be true, from a purely theoretical point of view, that it is possible to obtain completely identical structures using different technologies, but there is no good reason for the skilled person to proceed in this way when the same result can be achieved much more easily by repeatedly using the same technology.

The passage from p.6/20 to p.7/27 discloses that the OVM sub-assemblies are produced by following different procedures before being laminated together. As a consequence, the skilled person would expect the OVM to be different from each other.

The passage on p.11/26-29 discloses the possibility of generating each OVM using distinct origination

technologies. Again, the skilled person would expect this to lead to distinguishable OVMs. The passage on p.12/33-36 is somewhat less clear in this respect. The disclosure of p.12/9-11 explicitly requires the two OVMs to have a different diffractive brightness. P.13/6 requires the two OVMs to be complementary (and, therefore, different) zero-order diffractive devices. The same holds true for original claim 5. The passage of p.19/7-9 discloses a combination of a diffractive or holographic surface relief image and a volume/Bragg hologram.

As a consequence, the skilled reader considering the application as a whole would understand the application to disclose security features comprising superposed and differentiated diffractive or holographic OVMs.

4.2 Features 1-7 and 14-7

These features (see point 3.5) require the structures to generate a visually integrated image.

In point 2.2 of the decision under appeal, the opposition division referred to p.19/5-9:

"Finally it should be stressed that the inventive concept here is the concept of a visually integrated image provided for example, by the combination of a diffractive or holographic surface relief image and a volume/Bragg hologram and not the precise construction of the assembly ..."

The board is unable to endorse the counter-argument that this passage does not concern embodiments of the invention because feature 1-3 requires the OVM to have a surface relief microstructure rather than a volume

hologram. This is because this passage exposes the general inventive concept. The combination with a Bragg hologram is only given as an example.

The opposition division also stated that if the second structure is viewable through the first (as required by features 1-4 and 14-4), a visually integrated image is necessarily obtained. The board cannot find any fault in this reasoning.

4.3 Conclusion

The objection based on Article 100 c) EPC 1973 is unfounded.

5. Insufficiency of disclosure (Article 100 b) EPC 1973)

The appellant's objection is based on claim 3, according to which the first and second optically variable effect generating structures generate orthogonal holographic images, typically originated by classical holography.

The opposition division referred to what it called the "main rule" for Article 83 EPC according to which only one way to perform the invention must be clear to the skilled person. It argued that a patent could not conflict with Article 83 EPC if those skilled in the art could perform the subject-matter of an independent claim, irrespective of whether they could perform the subject-matter of a dependent claim. Accordingly, the opposition division did not even examine the subject-matter of claim 3.

The board cannot endorse this approach. The "main rule" asserted by the opposition division has no basis

in the EPC or in the jurisprudence of the boards of appeal. A dependent claim directed at a particular embodiment can give rise to an objection under Article 83 EPC if the skilled person does not know how to obtain this embodiment. Also, a dependent claim directed at subject-matter that the skilled person would not know how to obtain indicates that the invention defined in the corresponding independent claim is not sufficiently disclosed over the whole domain encompassed by the claim.

The disclosure of the patent in respect of the subject-matter of claim 3 can be found in paragraphs [0049] and [0050] of the patent:

"The designers of Kinegram®'s and Exelgram®'s and other forms of interferential and non-interferential lithographically generated diffractive optically variable devices, often exploit the fact that from a fabrication viewpoint they can readily alter the orientation (azimuthal angle) of their elemental grating structures by $\pm 90^\circ$ to generate orthogonal images. Such that for vertical orientation a first graphical image is diffracted into the observers eye, whilst rotating the device (about an axis normal to its plane) by 90° generates (horizontal orientation) diffracts or relays a second graphical image into the observers eye. This orthogonal image switch is a very powerful feature.

By contrast within a classical two-step rainbow hologram the ability to change the orientation (azimuthal) angle is constrained making the generation of truly orthogonal images difficult. Therefore an important aspect of certain examples

of this invention is the design feature that OVM1 and OVM2 contain orthogonal holographic images generated by classical holography. Though of course either or both microstructures may also contain other origination technologies (e.g. dot-matrix overlays)."

In view of this disclosure of the patent, there is no plausible case that the skilled person would be unable to obtain a security device according to claim 3.

Consequently, the board has reached the conclusion that the subject-matter of claim 3 is sufficiently disclosed for it to be carried out by the skilled person.

6. Novelty (Articles 100 a) and 54 EPC 1973)

6.1 Novelty over document D1

There was disagreement on whether document D1 disclosed features 1-6 and 1-7 (14-6 and 14-7).

6.1.1 Feature 1-6 (14-6)

The sweeping reference to document D2 in document D1 (page 14, line 5) is not sufficient to incorporate the entire disclosure of document D2 by reference. It cannot, therefore, be said that document D1 directly and unambiguously discloses feature 1-6 via page 20, lines 23 and following, of document D2, according to which various dyes can be used for coloration.

6.1.2 Feature 1-7 (14-7)

In this context, the embodiment of Figs. 12 and 13 of document D1 is most relevant. There was some discussion

on how these two figures related to each other.

Document D1 never states that the two drawings are representations of the same device (see page 3, lines 1 to 4), but repeatedly refers to Fig. 12 when describing Fig. 13 (see, for instance, page 15, lines 6 to 8, 21, and 25). Figs. 12 and 13 are also referred to in the context of Fig. 14 (see page 17, lines 22 and 29) and Fig. 15 (see page 18, lines 13 and 28). The overall impression is that the description does not strictly distinguish between embodiments but maintains a certain fluidity. Although Fig. 12 cannot be said to precisely correspond to a particular longitudinal or transversal cross-section of the object depicted in Fig. 13, the way in which the layers of the device of Fig. 12 are realised is clearly meant to apply to Fig. 13 as well.

The security device of Fig. 13 comprises at least two types of OVM:

- "The **relief structures 15** (Fig. 12) form **within the surface portions 50** kinematic motifs 52 which have an optical diffraction effect, ..." (page 15, lines 8 and 9; highlighting by the board).
The opacity of surface portions 50 is obtained by a thin metal or oxide layer 9 that is not transparent to visible light (see page 13, lines 22 to 24). However, there are transparent gaps 49 through which the underlying regions are visible (see page 13, lines 19 to 21). As pointed out above (see point 3.1), the upper OVM is composite: the discontinuous metallic layer 9 is part of that OVM.
- "The surface occupied by an **individual letter 53** has the **relief structures 10** (Fig. 12) so that the letters 53 light in different colours depending on

the respective direction of incidence of the light which impinges through the gaps 49 from the top side 5 of the carrier foil 3." (page 15, lines 20 to 23; highlighting by the board).

Fig. 13

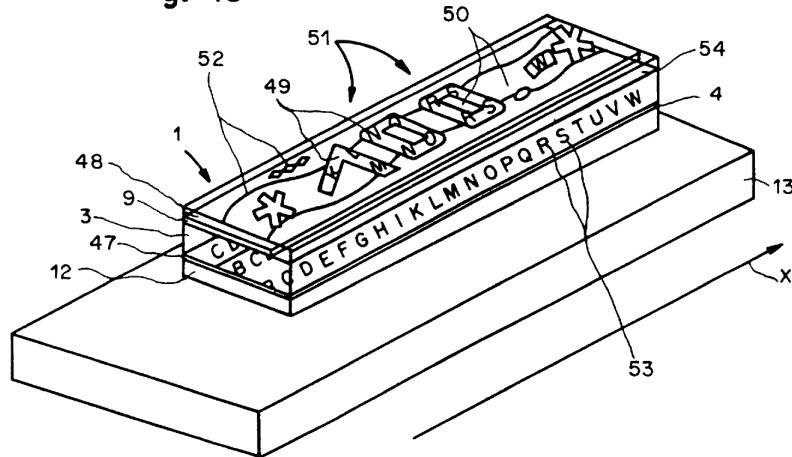
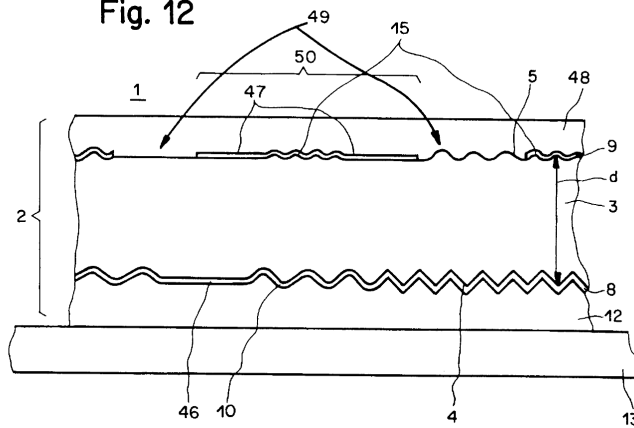

Fig. 12



The second OVM (i.e. relief structures 10) is visible through the transparent gaps 49 in the opaque layer 50, which forms part of the first OVM because the latter is formed by the relief structures 15 and the discontinuous metallic layer 9. Thus, the second OVM is viewable "through the first", which means that feature 1-4 is disclosed. The resulting image appears

relief structure 21, and that the second OVM consists of the lacquer layer 20, the diffraction element 5, the indicia 10 and the substrate 1. Document D3 clearly discloses that the relief structure 21 is provided on the upper surface 18 of intermediate layer 17 (see column 5, lines 40-44) and that the diffraction element 5 is formed in a layer of thermoplastic lacquer (column 5, lines 47-51). As a consequence, an understanding of the embodiment of Fig. 4 in which the first OVM does not comprise the intermediate layer appears to go against the teaching of document D3.

The printed images 14 cannot be said to be arranged between layers of an OVM. They are provided on top of the upper OVM.

The disclosure of document D3 in respect of coloured portions of the protective layer (claim 12, col. 7, lines 1-3) refers to the embodiment of Fig. 5 rather than to the embodiment of Fig. 4. In Fig. 4 there is no distinction made between neighbouring zones 24 and 25, which could be dyed differently.

Therefore, there is no direct and unambiguous disclosure of feature 1-6 (14-6) in the context of the embodiment of Fig. 4 of document D3.

6.2.2 Feature 1-5 (14-5)

The decision under appeal is silent on the disclosure of this feature. The passage in col. 4, lines 2-14, of document D3 only mentions a metal coating (which appears to be continuous) as an optional feature of the embodiment of Fig. 1. It cannot be said to provide a direct and unambiguous disclosure in respect of

feature 1-5 (14-5) in respect of the embodiment of Fig. 4.

6.2.3 Features 1-4 and 1-7 (14-4 and 14-7)

According to these features, the second OVM is viewable through the first, and the OVMs generate a visually integrated image. In the embodiment of Fig. 4 of document D3 (see above), at least part of the light reflected by the relief microstructure 5 can be observed through the relief microstructure 21. The resulting image can be said to appear united and undivided to an onlooker. It, therefore, qualifies as a visually integrated image as defined above (see point 3.5).

The argument that Fig. 4 is a side view and does not provide information on the lateral arrangement of diffraction structure 5 with respect to the relief structure 21 is unpersuasive because Fig. 4 is, like Fig. 1, not a side view but a cross-section through the security element (col. 2, line 46: "Querschnitt").

6.2.4 Conclusion

The subject-matter of claims 1 and 14 is new over the disclosure of document D3 because this document does not disclose features 1-5 and 1-6 (14-5 and 14-6).

6.3 Novelty over document D4

Document D4 discloses a security marking label. The label depicted in Fig. 3 has a first element 13 comprising a transparent lacquer layer 5 with an embossed holographic image (page 4, lines 7-8), and a second element 12 comprising a metallised lacquer

layer 10 with an embossed holographic image (page 2, lines 25-28 and page 4, line 35).

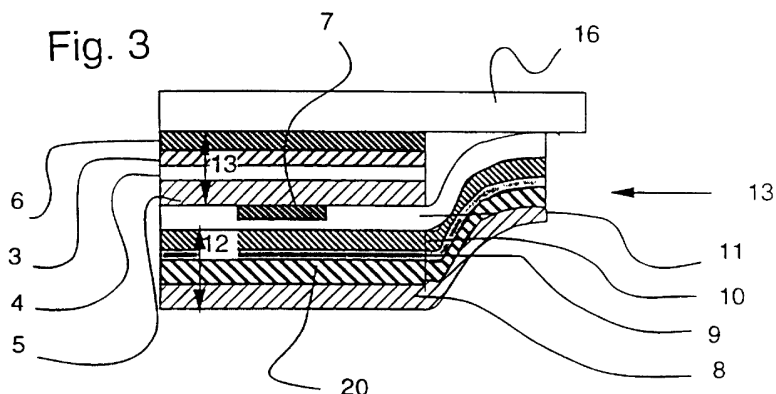

The opposition division found document D4 not to disclose features 1-4 and 1-7, according to which the second OVM is viewable through the first, and declared:

"Of course, logic requires that the hologram of layer 10 should be detectable in some way, but this has not to be in that it is viewable through the first: The hologram of layer 10 is visible next to the hologram of layer 5, since layer 12 extends beyond layer 13." (See point 4.3 of the decision under appeal.)

The board notes that Fig. 3 shows a cross-section of Fig. 1 along the line A-A (see page 4, lines 1-2).

Fig. 1

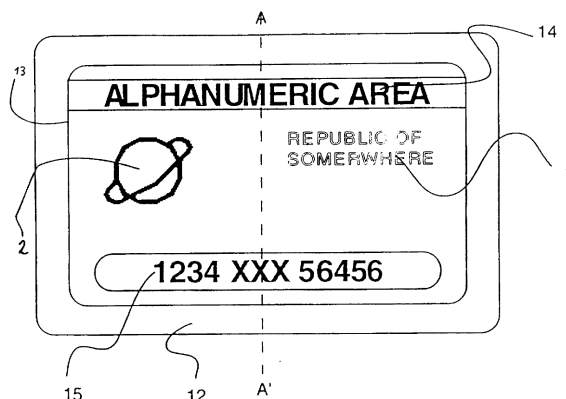
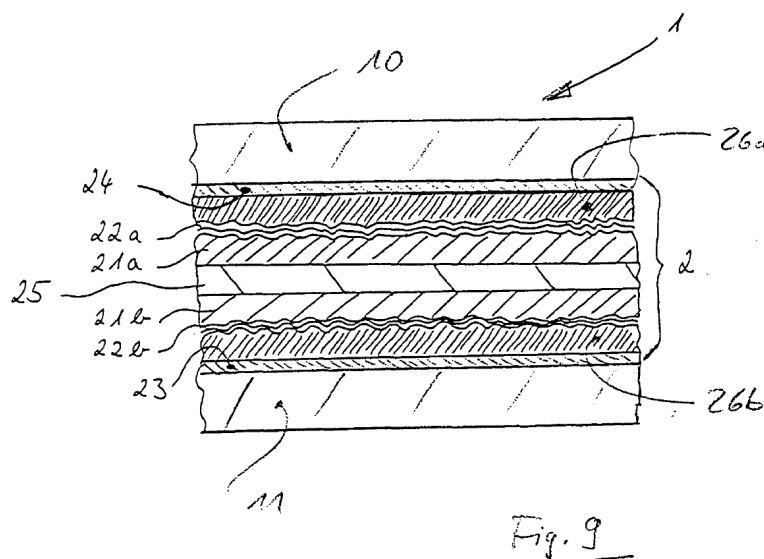

Fig. 1 does not suggest that any superposition of the holographic images (information 2 and 15) is intended. Therefore, at least feature 1-4 is not disclosed in document D4.

6.4 Novelty over document D5

The opposition division found document D5 not to disclose features 1-6 and 14-6.

Claim 10 of document D5 discloses that the security element comprises additional optical effects, such as printed images made from ink the optical effect of which depends on the angle of observation. There is no explicit disclosure on the precise location of the printed images. The argument that, irrespective of the precise choice, one of the options expressed by features 1-6 and 14-6 would necessarily be chosen, is unpersuasive. Fig. 9, on which the most relevant novelty attack is based, comprises two OVMs (metal coated relief layers 21a and 21b) separated by a supporting layer 25:



Those skilled in the art wishing to implement the teaching of claim 10 would most probably provide the printed images outside the metallic layers 22a and 22b, where they can be readily seen. They would not provide them between the OVMS (i.e. in layer 25) or in the OVMS (in layers 21a and 21b). Be that as it may, these variants cannot be said to be implicitly disclosed in document D5.

6.5 Novelty over document D6

The opposition division reached the conclusion that document D6 did not disclose feature 1-5 (14-5) and that, although feature 1-6 (14-6) and the combination of features 1-4 and 1-7 (14-4 and 14-7) were disclosed as such, they were not disclosed in combination.

The embodiment shown in Fig. 9 of document D6 is a superposition of four holograms, two of which are opaque (不透明) and two transparent (透明).

Paragraph [0043] describes what can be seen when looking at this composite structure from above and below.

【图9】

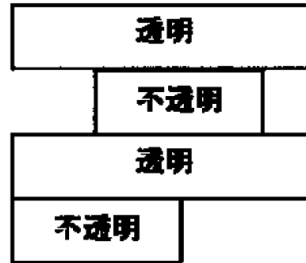

This very schematic representation, which is only concerned with a sequence and the relative position of transparent and opaque holograms, cannot be said to clearly and unambiguously disclose feature 1-5 (14-5). There is no disclosure of how the metallic layer extends in the region where the opaque regions end. Also, there is no reason to believe that a metallic layer responsible for the hologram being opaque is discontinuous.

Document D6 discloses feature 1-6 (14-6) because paragraph [0078] provides the general teaching that resin layers of the hologram can be coloured. This means that dye or pigments is provided in at least one layer of the OVM.

Paragraphs [0034] and [0035] refer to the embodiments of Fig. 7. It is legitimate to combine this teaching with the general teaching of paragraph [0078]. Therefore, the board cannot endorse the statement of the opposition division that feature 1-6 (14-6) and the combination of features 1-4 and 1-7 (14-4 and 14-7) are not disclosed in combination.

To sum up, only feature 1-5 (14-5) is not disclosed in document D6.

6.6 Conclusion on novelty

The claimed subject-matter is new over the cited prior art. The following table summarises the distinguishing features with respect to the different documents:

Document	Distinguishing feature(s)
D1	1-6 (14-6)
D3	1-5 (14-5), 1-6 (14-6)
D4	1-4 (14-4)
D5	1-6 (14-6)
D6	1-5 (14-5)

7. Inventive step

The board applies the problem-solution approach to examine whether the claimed subject-matter involves an inventive step. Document D1 is used as the starting point.

7.1 Difference

As explained in point 6.1 above, claims 1 and 14 differ from the disclosure of document D1 by feature 1-6 and 14-6, respectively.

7.2 Objective technical problem

The opposed patent is silent on the technical effect of feature 1-6 but discloses in paragraph [0044] that "pigments may provide colouration [sic] or luminescent effects (phosphorescent and fluorescent)". The skilled person would expect feature 1-6 to have the technical

effect of allowing further colour effects, which increases the difficulty of counterfeiting. Therefore, the objective technical problem solved by feature 1-6 (14-6) is to make counterfeiting more difficult.

7.3 Obviousness

Document D8 discloses means to increase the difficulty to counterfeit security devices. After an overview of the state of the art, the description of the invention is introduced with the statement: "Although the use of these devices leads to a relatively secure product which is difficult to counterfeit, there is a need for even more secure devices to be made." (page 3, lines 14-15). In view of this very general statement, the board is unable to endorse the argument that the skilled person would disregard document D8 because it deals with the prevention of fraud by reuse rather than by counterfeiting.

The core teaching of document D8 is to provide an optically diffracting layer and an at least partially reflective layer which together generate a first image, and a non-optically diffracting second image within the device in association with the first image (see claim 1). More concretely, this is being achieved by printed ink images 4 being provided at the interface between the embossed thermoplastic layer 7 and the reflective metal layer(s) 5 (see all the figures).

Fig.2.

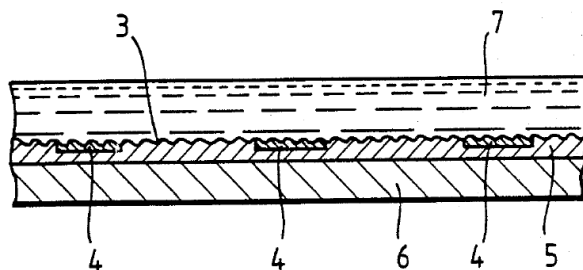

Thus, document D8 teaches the skilled person to provide printed ink images between layers of the OVM. When applying this teaching to the optical information carrier according to document D1, the skilled person would obtain a security device according to claim 1.

The argument that document D8 sees the printed ink as a means to pattern the otherwise large and contiguous holograms by concealing the optically variable effect, and that - considering that there are already optically inactive areas in the devices of document D1 - the skilled person would refrain from seeking and incorporating additional means of producing optically inactive areas, is unpersuasive because it is based on a biased reading of document D8. When setting forth the core of the invention, document D8 states that "in an optical device of the kind described, a non-optically diffracting, second image is provided within the device in association with the first image" (see page 3, lines 16 to 19, immediately following the description of the problem to be solved). Accordingly, the first purpose of the printed ink is to constitute a non-optically diffracting, second image, and not to conceal the optically variable effect.

Thus, claims 1 and 14 lack inventive step over the disclosure of documents D1 and D8 in combination.

As a consequence, the respondent's main request (maintaining the patent as granted) cannot be allowed.

8. Remittal to the department of first instance

Having considered that both parties were in favour of a remittal, the board has decided to remit the case to the department of first instance to offer the parties two levels of jurisdiction.

Order

For these reasons it is decided that:

1. The decision under appeal is set aside.
2. The case is remitted to the first instance for further prosecution.

The Registrar:

The Chairman:



N. Schneider

M. Poock

Decision electronically authenticated