

Internal distribution code:

- (A) [-] Publication in OJ
(B) [-] To Chairmen and Members
(C) [-] To Chairmen
(D) [X] No distribution

**Datasheet for the decision
of 27 February 2019**

Case Number: T 1716/16 - 3.2.02

Application Number: 10723101.1

Publication Number: 2437830

IPC: A61M5/315

Language of the proceedings: EN

Title of invention:

ASSEMBLY FOR A DRUG DELIVERY DEVICE AND DRUG DELIVERY DEVICE

Patent Proprietor:

Sanofi-Aventis Deutschland GmbH

Opponents:

Bock Wolfgang
Ypsomed AG (intervener)

Headword:

Relevant legal provisions:

EPC R. 144
EPC Art. 123(2), 83, 84, 54(3), 56, 128(4), 111(1)
RPBA Art. 13(1)

Keyword:

Remittal for auxiliary request 2 - no
Novelty (main request and auxiliary request 1 - no; auxiliary request 2 - yes)
Added subject-matter (auxiliary request 2 - no)
Clarity and sufficiency of disclosure (auxiliary request 2 - yes)
Inventive step (auxiliary request 2 - yes)
Exclusion of documents from file inspection

Decisions cited:

T 0839/05

Catchword:



Beschwerdekammern
Boards of Appeal
Chambres de recours

Boards of Appeal of the
European Patent Office
Richard-Reitzner-Allee 8
85540 Haar
GERMANY
Tel. +49 (0)89 2399-0
Fax +49 (0)89 2399-4465

Case Number: T 1716/16 - 3.2.02

D E C I S I O N
of Technical Board of Appeal 3.2.02
of 27 February 2019

Appellant: Sanofi-Aventis Deutschland GmbH
(Patent Proprietor) Brünigstraße 50
65929 Frankfurt am Main (DE)

Representative: Keil & Schaafhausen
Patent- und Rechtsanwälte PartGmbH
Friedrichstraße 2-6
60323 Frankfurt am Main (DE)

Appellant: Bock Wolfgang
(Opponent 1) Stuntzstrasse 33
81677 München (DE)

Representative: Samson & Partner Patentanwälte mbB
Widenmayerstraße 6
80538 München (DE)

Intervener: Ypsomed AG
(Opponent 2) Brunnmattstrasse 6
3401 Burgdorf (CH)

Representative: SSM Sandmair
Patentanwälte Rechtsanwalt
Partnerschaft mbB
Joseph-Wild-Straße 20
81829 München (DE)

Decision under appeal: **Interlocutory decision of the Opposition**
Division of the European Patent Office posted on
31 May 2016 concerning maintenance of European
Patent No. 2437830 in amended form

Composition of the Board:

Chairman E. Dufrasne

Members: M. Stern
 P. L. P. Weber

Summary of Facts and Submissions

- I. Appeals were lodged by the patent proprietor and the opponent against the interlocutory decision of the Opposition Division posted on 31 May 2016 concerning the maintenance of European patent 2 437 830 in amended form.
- II. The appellant/patent proprietor (hereinafter "the patent proprietor") filed notice of appeal on 19 July 2016, paying the appeal fee the same day. A statement setting out the grounds of appeal was received on 10 October 2016.
- III. The appellant/opponent (hereinafter "the opponent") filed notice of appeal on 10 August 2016, paying the appeal fee the same day. A statement setting out the grounds of appeal was received on 10 October 2016.
- IV. With a letter dated 26 February 2018 an intervention was filed by a third party (hereinafter "the intervener"), including documents K1 to K6. The opposition fee was paid the same day. The intervener requested acceleration of the appeal proceedings.
- V. The following documents are relevant for the present decision:

D9: WO-A-2005/053778
D12: WO-A-2009/132778
- VI. Oral proceedings were held on 27 February 2019.

The patent proprietor requested that the decision under appeal be set aside and that the patent be maintained as granted, or, in the alternative, on the basis of one

of the auxiliary requests 1 to 8, filed by letter dated 31 July 2018, and auxiliary requests 9 to 14, filed as auxiliary requests 1 to 6 by letter dated 10 October 2016.

The opponent and the intervener requested that the decision under appeal be set aside and that the patent be revoked. The intervener requested, moreover, that documents K1 to K6 or, alternatively, documents K1, K3 and K5 be excluded from public file inspection.

VII. Claim 1 of the **main request** (patent as granted) reads as follows (feature numbering added by the Board):

- "[1.1] An assembly for a drug delivery device,
comprising:
- [1.2] - a housing (13) having a proximal end (17) and a distal end (15);
 - [1.3] - a dose member (23) which is displaceable in the proximal direction with respect to the housing for setting of a dose of a drug (5);
 - [1.4] - a clutch member (28) which is displaced in the proximal direction with respect to the housing when setting the dose; and
 - [1.5] - a stop member (30) configured to define a clutch stop position for the proximal displacement of the clutch member with respect to the housing, with the clutch member, when in the clutch stop position, being prevented from further displacement in the proximal direction with respect to the housing,
 - [1.6] wherein
 - the clutch member and the dose member are configured to mechanically cooperate with one another when the clutch member is in the clutch stop position, thereby preventing further

displacement of the dose member in the proximal direction with respect to the housing during setting of the dose."

- VIII. Claim 1 of **auxiliary request 1** (held allowable by the Opposition Division) reads as claim 1 of the main request, adding at the end the expression:

"characterized in that a clutch spring member (43) prevents the dose member (23) from cooperating mechanically with the clutch member (28) when the clutch member (28) is out of the clutch stop position."

- IX. Claim 1 of **auxiliary request 2** reads as claim 1 of auxiliary request 1, with feature [1.5] amended by the following underlined features:

"a stop member (30) configured to define a clutch stop position for the proximal displacement of the clutch member with respect to the housing, with the clutch member, when in the clutch stop position, abutting the stop member and being prevented from further displacement in the proximal direction with respect to the housing".

- X. The arguments of the patent proprietor relevant for the present decision are summarised as follows:

Main request - novelty over D12

The embodiment depicted in Figure 3 of D12 was not an enabling disclosure, since certain features in the drawing were not compatible with the corresponding description. As a consequence, the skilled person would not be able to render the embodiment of Figure 3 into practice.

For example, the dose dial sleeve 27 was depicted (at the bottom of Figure 3) as having a ridge which fixedly engaged locking ring 69. Hence, since clutch ring 68 was welded together with the dose dial sleeve 27, rings 68 and 69 (locking elements 64, 66) would remain at a fixed distance and would not be able to lock together as explained in the description. Consequently, rings 68 and 69 (locking elements 64, 66) did not equate to a "clutch member". The second stop element 36 could not come even into the vicinity of the supposed clutch member 66 at any time. Hence, there was no possibility of a direct contact between the stop member and the clutch member, as required according to claim 1.

Furthermore, Figure 3 depicted the dose limiting member 28 as threadedly engaged not only to the insert 74 (as described on page 44, lines 18 to 19), but also to the dose dial sleeve 27. Accordingly, the insert 74 could not move axially with respect to the dose dial sleeve 27. Since the insert 74 was described to be fixed to ring 69 (through engaging feature 75), and the dose dial sleeve 27 was described to be welded to ring 68, rings 68 and 69 (making up locking elements 64, 66) would remain at a fixed distance and would not be able to lock together as explained in the description.

The intervener conflated the limiting mechanism (stops 35 and 36) preventing the dose limiting member 28 from rotating in the direction in which the dose was set and the additional locking mechanism formed by locking member 64 and locking feature 66. Moreover, the second stop element 36 in D12 could not come even into the vicinity of the supposed clutch

member (64, 66) at any time. Hence, there was no possibility of a direct contact between the stop member and the clutch member.

Auxiliary request 1 - novelty over D12

In D12, the biasing means were disclosed to hold locking member 64 and locking feature 66 apart. The claim, however, required that the clutch spring member prevented the dose member (27 in D12) from cooperating mechanically with the clutch member (64, 66 in D12). Moreover, D12 omitted to specify that the "biasing means" in Figure 3 were specifically a spring.

Auxiliary request 2

- Remittal

At the oral proceedings, the patent proprietor no longer requested that the case be remitted to the Opposition Division for consideration of the objections raised by the intervener against the main request and auxiliary request 1. However, remittal was requested for consideration of the intervener's objections against auxiliary request 2 which had not been considered at first instance. Pending infringement proceedings could be a reason for accelerated proceedings. However, in the present case, the intervener requested before the Swiss Bundespatentgericht (Federal Patent Court) to defer the discussion of validity of the patent and to have the question of infringement decided first. This showed that the intervener was not interested in accelerated appeal proceedings. Remittal to the department of first instance would not negatively affect the intervener's position.

- Admissibility of objections under Article 83 EPC

The objections under Article 83 EPC raised by the intervener should not be admitted into the proceedings since they were not raised at the time of the intervention, but about a month before the oral proceedings.

- Articles 123(2), 84, 83, 54 and 56 EPC

The arguments regarding the substantial objections on Articles 123(2), 84, 83, 54 and 56 EPC which are relevant for the present decision are those on which the reasons set out below are based.

XI. The arguments of the opponent and the intervener relevant for the present decision are summarised as follows:

The intervener invoked legitimate personal and economic interests for excluding documents K1 to K6 from public file inspection, since they contained personal and economic information which were prejudicial to the legitimate personal and economic interests of the intervener and were not relevant for establishing the admissibility of the intervention. Moreover, it was sufficient that the Board had knowledge of the basis for the intervention without making these documents public. At least, documents K1, K3 and K5 should be excluded from file inspection.

Main request and auxiliary request 1

The arguments regarding novelty of the subject-matter of claim 1 of the main request and auxiliary request 1

which are relevant for the present decision are those on which the reasons set out below are based.

Auxiliary request 2

- Remittal

The case should not be remitted to the Opposition Division as this would unduly lengthen the proceedings. Accelerated appeal proceedings had been requested in view of pending infringement proceedings before the Swiss Bundespatentgericht. Moreover, even the new objections raised by the intervener against the claims of auxiliary request 2 were essentially similar to those raised and discussed in the context of the preceding requests. There was no right to have each and every new aspect examined at two instances.

- Article 123(2) EPC

The expression added to claim 1 specifying that the clutch member was "abutting the stop member" was an unallowable intermediate generalisation of the disclosure of page 9, lines 4 to 9. Abutting of the clutch member at the stop member was only possible once the stop member had been successively driven in the distal direction, thus arriving at a position between the distal initial position and the maximum proximal end position of the clutch member. The claim did not specify these features. It omitted, moreover, to specify that the abutting takes place only when a "subsequent" dose is set. The cited passage made it clear that the clutch member was stopped *by* abutting the stop element. In claim 1, this causality was missing too.

- *Article 84 EPC*

The addition of "abutting the stop member" was unclear since the claim left open whether or not the clutch member abutted the stop member or not, when the clutch member was not in the stop position.

- *Article 83 EPC*

There was no valid reason not to admit all objections raised under Article 83 EPC. The arguments presented by the intervener one month before the oral proceedings concerned entirely similar technical aspects as those mentioned by the opponent in its statement of grounds of appeal. They did not significantly increase the complexity of the case, and the patent proprietor had not been surprised by them.

The patent was silent as to how the skilled person should put into practice an assembly according to claim 1 where the clutch member and the dose member were not connected with each other, thereby ensuring that the clutch member and the dose member were configured to mechanically cooperate with one another when the clutch member was in the clutch stop position, at the same time ensuring that the clutch member and the dose member did not mechanically cooperate with one another before the clutch member was in the clutch stop position. Paragraph [0064] of the patent required that the engagement member of the clutch member and the engagement feature of the dose member were biased away from one another to keep the dose member and the clutch member out of interaction. Only one example for a stop member on the piston rod 12 was presented in the patent, i.e. in paragraph [0055]. However, since claim 1 left it open where the stop member should be

placed, embodiments other than the one described fell under claim 1. However, the skilled person using his common general knowledge would not be in a position to implement such further alternatives.

- *Novelty*

It was possible to consider that the clutch member in D12 was not only formed by locking member 64 and locking feature 66, but by dose limiting member 28 too. Since the latter included a first stop 35 which engaged the second stop member 36 (the claimed "stop member"), such a "clutch member" abutted the stop member as claimed.

- *Inventive step*

The claimed subject-matter lacked inventive step over document D9. In particular, departing from D9 as the closest prior art, the skilled person would readily modify the dose limiting mechanism of D9 and arrive at the features [1.6] of claim 1. Instead of the interaction of protrusion 341 of the scale drum 30 with the housing 20 in D9, the skilled person would provide the piston rod guide 40 with a ratchet interacting with the scale drum 30 for limiting rotation thereof. The skilled person was aware of ratchets as an effective blocking mechanism. Therefore, feature [1.6] of claim 1 would be readily considered as the most obvious solution. Furthermore, the skilled person would also arrive at the claimed solution without inventive step when starting from any one of D1 to D5. A further objection based on D12 was withdrawn during the oral proceedings.

Reasons for the Decision

1. The appeals and the intervention are admissible.
2. *Exclusion of documents from public file inspection*
 - 2.1 As evidence for the admissibility of the intervention, documents K1 to K6 were filed. The intervener requested that all documents K1 to K6, or, alternatively, only documents K1, K3 and K5 be excluded from public file inspection since they contained personal and economic information which were prejudicial to the legitimate personal and economic interests of the intervener and were not relevant for establishing the admissibility of the intervention.
 - 2.2 Pursuant to Rule 144 EPC and Article 1(2) (a) of the Decision of the President of the European Patent Office dated 12 July 2007 concerning documents excluded from file inspection under Article 128(4) EPC (OJ EPO 2007, Special edition No. 3, J3, 125), documents are excluded from file inspection at the reasoned request of a party or its representative, if their inspection would be prejudicial to the legitimate personal or economic interests of natural or legal persons.
 - 2.3 Documents K2, K4 and K6 eliminate confidential information from the more detailed documents K1, K3 and K5, respectively.

Documents K2, K4 and K6 retain all necessary information for allowing the Board to establish the admissibility of the intervention (K2 and K4 provide evidence for the patent proprietor instituting proceedings for infringement of the present patent against the intervener on 29 November 2017, and K6

shows that the intervener received the corresponding notification on 1 December 2017). Contrary to the intervener's opinion, not only should the Board be in a position to rule on this matter, but also the public should have access to the information on which the Board reached this decision. This information being contained in documents K2, K4 and K6, the Board considers that they are to be made publicly available.

The Board accepts the intervener's view that the more detailed documents K1, K3 and K5 contain additional information regarding, inter alia, economic data concerning the intervener and its suppliers, as well as market data, the divulagation of which may be prejudicial to the intervener's legitimate personal and economic interests. K1, K3 and K5 are therefore to be excluded from file inspection pursuant to Rule 144(d) EPC.

3. *The invention*

The invention relates to an assembly for a drug delivery device in which the user sets the dose of a drug to be delivered and subsequently delivers the dose. When setting the dose, a clutch member is displaced in the proximal direction with respect to the housing and a stop member is configured to define a stop position for the proximal displacement of the clutch member. The clutch member and the dose member are configured to mechanically cooperate with one another when the clutch member is in the clutch stop position, thereby preventing further displacement of the dose member in the proximal direction with respect to the housing during setting of the dose (paragraph [0005]). Thus, setting of a dose of the drug which exceeds the actually available amount of drug may

be prevented, thereby reducing the risk of administering an amount of drug which is less than the dose set (paragraph [0008]).

4. *Main request - novelty*

4.1 Document D12, a previous application by the patent proprietor, is, undisputedly, prior art under Article 54(3) EPC.

Document D12 discloses on page 43, line 26 to page 46, line 7 an assembly for a drug delivery device, which is depicted in Figure 3:

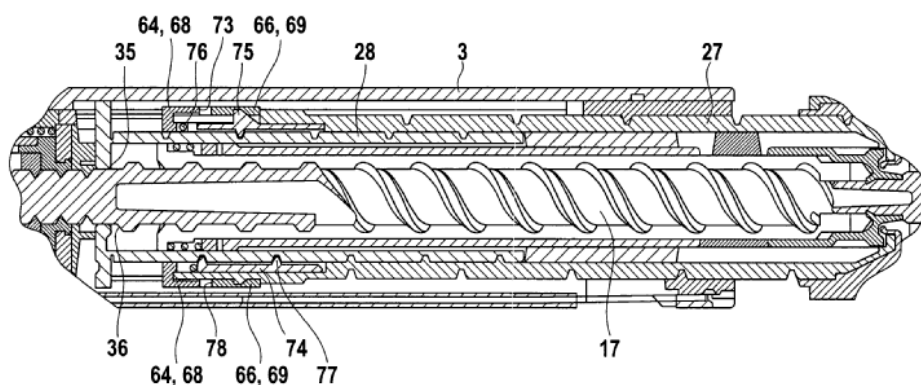

Fig. 3

4.2 The assembly comprises a housing (3) and a dose member (dose dial sleeve 27) which is displaceable in the proximal direction with respect to the housing for setting a dose of a drug (as described for the embodiment of Figure 1 on page 32, lines 16 to 18, but which applies to that of Figure 3 as well). In the context of Figure 3, movement in the proximal direction is to the right of the drawing. An insert 74 is provided within the dose dial sleeve 27, the insert 74

being non-rotatably attached to the dose dial sleeve 27, e.g. by means of splines (page 44, lines 10 to 11). The insert 74 is capable of moving axially a certain distance with respect to the dose dial sleeve 27. Since the insert 74 carries an engaging feature 75 engaging a locking ring 69, the latter follows the axial movement of the insert 74 (page 44, lines 11 to 16). The insert 74 and the dose dial sleeve 27 are axially movable together until the first and second stop elements 35, 36 catch. The first stop element 35 is a flange formed on a dose limiting member 28 which catches a radially outwardly directed stop, the second stop element 36, on the piston rod 17 (page 44, lines 24 to 32).

When these stop elements abut each other, the dose limiting member 28 is stopped from moving further in the proximal direction relative to the piston rod 17 and the housing 3. Any further force exerted by the user on the dose dial sleeve 27 in the dose increasing direction results in the dose limiting member 28 holding the insert 74 and the locking feature 66 in a certain axial position with respect to the housing 3 (page 45, lines 9 to 17). The dose dial sleeve 27 entrains the welded locking member 64 (clutch ring 68 comprising teeth 73) (page 43, lines 29 to 31) to lockingly engage the locking feature 66 (locking ring 69 comprising teeth 78) (page 45, lines 17 to 19). In this locked state, the locking member 64 and the welded dose dial sleeve 27 are prevented from rotationally and axially moving with respect to the housing 3 in a dose increasing direction (page 45, lines 21 to 25), locking feature 66 being splined to housing 3 (page 44, lines 4 to 7).

Thus, locking member 64 and locking feature 66 (comprising rings 68 and 69, respectively) form a "clutch member which is displaced in the proximal direction with respect to the housing when setting the dose" as defined in feature [1.4] of claim 1. Moreover, second stop element 36 constitutes a "stop member configured to define a clutch stop position for the proximal displacement of the clutch member (64, 66) with respect to the housing (3), with the clutch member, when in the clutch stop position, being prevented from further displacement in the proximal direction with respect to the housing", as defined in feature [1.5] of claim 1. Furthermore, "the clutch member (64, 66) and the dose member (27) are configured to mechanically cooperate with one another when the clutch member (64, 66) is in the clutch stop position, thereby preventing further displacement of the dose member (27) in the proximal direction with respect to the housing during setting of the dose", as defined in feature [1.6] of claim 1.

- 4.3 The patent proprietor argued, firstly, that the embodiment depicted in Figure 3 of D12 was not an enabling disclosure, since certain features of the drawing were not compatible with the description. As a consequence, the skilled person would not be able to render the embodiment of Figure 3 into practice.

For example, the dose dial sleeve 27 was depicted (at the bottom of Figure 3) as having a ridge which fixedly engaged locking ring 69. Hence, since the clutch ring 68 was welded together with the dose dial sleeve 27, rings 68 and 69 (locking elements 64, 66) would remain at a fixed distance and would not be able to lock together as explained in the description.

Hence, rings 68 and 69 (locking elements 64, 66) could not equate to a "clutch member".

Furthermore, Figure 3 depicted the dose member 28 as threadedly engaged not only to the insert 74 (as described on page 44, lines 18 to 19), but also to the dose dial sleeve 27. Accordingly, the insert 74 could not move axially with respect to the dose dial sleeve 27. Since the insert 74 was described to be fixed to ring 69 (through engaging feature 75) and the dose dial sleeve 27 was described to be welded to ring 68, these two rings (making up locking elements 64, 66) would remain at a fixed distance and would not be able to lock together as explained in the description.

- 4.4 The Board considers that the description in itself is clear and conclusive as to its teaching and technical soundness. As indicated on page 44, lines 4 to 7, the locking feature 66 is splined to the housing 3, and as indicated on page 44, lines 10 to 11, the insert 74 is non-rotatably attached to the dose dial sleeve 27. For the skilled person it is hence self-evident that the locking feature 66 must have a circular groove to permit the rotation of engaging feature 75 in it. This circular groove is shown at the bottom of Figure 3. Based on this insight, the skilled person would just disregard the erroneously depicted ridge in Figure 3.

The skilled person would also immediately recognise that the depicted threaded engagement between the dose limiting member 28 and the dose dial sleeve 27 is technically unfeasible. According to the description, the insert 74 is axially movable with respect to the dose dial sleeve 27. This axial movement is necessary for locking elements 64 and 66 coming together and

engaging teeth 73 and 78. Based on this insight, the skilled person would also disregard, in Figure 3, the erroneously depicted threaded engagement between the dose limiting member 28 and the dose dial sleeve 27.

In summary, the skilled person would immediately recognise the aforementioned obvious drawing imperfections in Figure 3 as such, and consequently disregard them when constructing an assembly following its clear and conclusive description.

- 4.5 The patent proprietor argued, moreover, that the second stop element 36 in D12 could not come even into the vicinity of the supposed clutch member at any time. Hence, there was no possibility of a direct contact between the stop member and the clutch member.

The Board finds this argument unconvincing, since the claim does not define any such "direct contact" between the stop member and the clutch member.

- 4.6 Hence, the subject-matter of claim 1 of the main request lacks novelty within the meaning of Article 54(1) and (3) EPC.

5. *Auxiliary request 1 - novelty*

- 5.1 D12 discloses, moreover, a biasing means 76 holding the insert 74 (and with it, the engaged locking feature 66/locking ring 69) and the dose dial sleeve 27 in a certain axial position until the first and second stop elements 35, 36 catch (page 45, lines 6 to 9). That is, until this "stop position" is reached, the biasing means prevent the locking feature 66 and locking member 64 (the claimed "clutch member") from coming together and locking with each other. In the unlocked

position, the dose dial sleeve 27 and locking feature 66 are at a certain axial distance, and thus not in "mechanical cooperation". Moreover, D12 explains on page 19, lines 4 to 10 that the term "biasing means" according to the invention disclosed may be, inter alia, a spring. In Figure 3, the biasing means 76 are depicted as two diametrically opposed and axially displaced circular cross-sections, consistent with the disclosure of biasing means as a spring.

Hence, D12 discloses "a clutch spring member (76) (which) prevents the dose member (27) from cooperating mechanically with the clutch member (64, 66) when the clutch member is out of the clutch stop position", as defined in claim 1 of auxiliary request 1.

5.2 Consequently, the subject-matter of claim 1 of auxiliary request 1 lacks novelty within the meaning of Article 54(1) and (3) EPC.

6. *Auxiliary request 2*

6.1 *Remittal*

6.1.1 At the oral proceedings, the patent proprietor no longer requested that the case be remitted to the Opposition Division for consideration of the objections raised by the intervener against the main request and auxiliary request 1. It requested, instead, the remittal of the case for consideration of the intervener's objections against auxiliary request 2 which had not been considered at first instance.

6.1.2 When fresh evidence or arguments are filed during appeal proceedings which raise a case substantially different from that on which the contested decision was

based, the case should generally be remitted to the department of first instance where this is demanded by fairness to all parties (as cited in Case Law of the Boards of Appeal, 8th edition 2016, IV.E.7.2.4).

In the present case, the intervener raised new objections based, *inter alia*, on new evidence (documents D9 to D14). Nevertheless, the patent proprietor agreed that the Board rules on the main request (the patent as granted) and auxiliary request 1 (held allowable by the Opposition Division) taking into account all objections, including also those raised by the intervener for the first time during the appeal proceedings. In view of this, the patent proprietor's request that auxiliary request 2 be examined at two instances instead does not appear consistent and convincing, in particular since the subject-matter of claim 1 of auxiliary request 2 corresponds to a further limitation of what is claimed in auxiliary request 1 and the objections raised against it are essentially similar to the objections raised against the claims of the preceding requests. There is, in accordance with established case law of the Boards of Appeal, no absolute right for a party to have each and every aspect of a case examined at two instances (T 839/05).

- 6.1.3 Moreover, the opponent and the intervener did not agree to a remittal, as this would unduly lengthen the proceedings. The intervener had requested acceleration of the appeal proceedings in view of pending infringement proceedings before the Swiss Bundespatentgericht (Federal Patent Court). The fact that in the latter proceedings the intervener may have chosen to defer the discussion of validity of the patent and to have the question of infringement decided first, is immaterial to the urgency for a prompt final

decision of the present appeal expressed by the intervener. Hence, a remittal of the case to the department of first instance would certainly negatively affect the intervener's justified interest in a speedy settlement of the present case.

6.1.4 Thus, with due consideration of the need to avoid further delays, the Board decides not to remit the case for consideration of auxiliary request 2, but to decide on it itself in accordance with Article 111(1) EPC.

6.2 *Article 123(2) EPC*

Claim 1 defines the subject-matter of original claims 1 and 2, supplemented by the definition of the clutch member, when in the clutch stop position, "abutting the stop member".

This definition is properly based on page 9, lines 6 to 9 of the application as filed. This passage of the description refers, firstly, to stopping the clutch member when setting a dose from (axial) displacement (in the proximal direction), a feature which is already contained in features [1.5] and [1.6] of claim 1. This passage of the description explains, moreover, that the stopping of the clutch member in the stop position is caused "by abutting the stop member". This is entirely equivalent to the expression recited in claim 1 defining that when the clutch member reaches the clutch stop position, the clutch member abuts the stop member and is prevented from further displacement in the proximal direction.

The Board sees, moreover, no inextricable link to the features mentioned before the aforementioned passage on page 9, lines 6 to 9, since they refer not to the dose

setting defined in the claim, but to the dose delivery before the dose setting. It is therefore not relevant to mention in the claim that the dose setting is "subsequent" to the preceding delivery of a dose.

It follows that claim 1 of auxiliary request 2 satisfies the requirements of Article 123(2) EPC.

6.3 *Clarity (Article 84 EPC)*

The intervener briefly indicated in writing that the addition of the feature "abutting the stop member" led to a lack of clarity, since claim 1 left it open whether the clutch member abutted the stop member or not, when the clutch member was not in the stop position. No further explanation for the clarity objection was given.

The Board is unable to find any ambiguity in something which claim 1 does *not* define, namely the abutting (or the lack of it) of the clutch member with the stop member when the clutch member is not in the stop position. The features of claim 1 other than the aforementioned abutting feature were already contained in claims 1 and 2 of the patent as granted and are thus not open to an objection concerning their clarity.

It follows that claim 1 of auxiliary request 2 satisfies the requirement of clarity in accordance with Article 84 EPC.

6.4 *Sufficiency of disclosure (Article 83 EPC)*

6.4.1 *Admissibility*

The patent proprietor requested the objections under Article 83 EPC raised by the intervener not to be admitted into the proceedings since the intervener did not raise these objections with its intervention, but about a month before the oral proceedings.

It is first to be noted that objections under Articles 100(b) and 83 EPC were brought forward by the opponent in its statement of grounds of appeal, particularly contesting the decision by the Opposition Division regarding these grounds. Therefore, these objections are part of the opponent's case.

In its letter filed about one month before the oral proceedings, the intervener endorsed these objections and elaborated further on them. In the Board's view, the new arguments presented by the intervener touch on entirely similar technical aspects as those mentioned by the opponent in its statement of grounds of appeal. Moreover, they do not significantly increase the complexity of the case. Having been submitted about one month before the oral proceedings, the patent proprietor was given enough time to respond to them in an adequate way.

The Board sees, therefore, no valid reason not to consider these added arguments as well (Article 13(1) RPBA).

6.4.2 Paragraphs [0059] to [0061] of the patent describe how the dose member 23 and the clutch member 28 mechanically cooperate with one another. These

paragraphs, referring to Figures 3 and 4, describe in detail how the dose member 23 and the clutch member 28 engage with one another, namely through engagement member 40 of the clutch member 28 and engagement feature 41 of the dose member 23. The engagement member and engagement feature may comprise a plurality of respectively mating teeth. Consequently, the skilled person is provided with the necessary information to implement feature [1.6] of claim 1.

6.4.3 Furthermore, paragraph [0064] referring to Figure 5 describes a clutch spring member 43 which prevents mechanical cooperation of the dose member 23 and the clutch member 28, when the latter is out of the clutch stop position, by keeping the engagement member 40 of the clutch member 28 at a predetermined distance from engagement feature 41 of the dose member 23. This detailed description enables the skilled person to implement the clutch spring member as defined in the characterising portion of claim 1.

6.4.4 As acknowledged by the intervener, paragraph [0055] of the patent describes a stop member according to feature [1.5] of claim 1. The fact that claim 1 does not specify further details described in this embodiment, for example, that the stop member 30 is connected to or integrated in the piston rod 12, is no reason to conclude insufficiency of disclosure. The present case corresponds to the common practice where the independent claim is drafted in broader terms than a specific example described.

Hence, in accordance with established case law as cited in Case Law of the Boards of Appeal of the European Patent Office, 8th edition 2016, II.C.4.2, the Board considers also this aspect of the invention

(feature [1.5]) to be sufficiently disclosed, since at least one way that enables the skilled person to carry it out is clearly indicated.

6.4.5 It follows that claim 1 of auxiliary request 2 satisfies the requirements of sufficiency of disclosure within the meaning of Article 83 EPC.

6.5 *Novelty*

6.5.1 The definition in claim 1 of the clutch member in the clutch stop position "*abutting the stop member*" establishes novelty over document D12. In fact, Figure 3 of D12 shows that the piston rod 17 with its stop element 36 is positioned at the centre of the device, and that the clutch member (64, 66) is located radially and axially spaced from the stop element 36. Thus, a contact or abutment of these two components is absent in D12.

The intervener argued that the clutch member in D12 could be considered to be formed not only by locking member 64 and locking feature 66, as mentioned above, but by dose limiting member 28 too. Since the latter included a first stop 35 which engaged the second stop member 36 (the claimed "stop member"), such a "clutch member" would be abutting the stop member 36. The Board disagrees with this view since the dose limiting member 28 is, as such, an element for limiting the dose set, that is, a distinct and separate element to locking member 64 and locking feature 66 which have a clutching function.

The subject-matter of claim 1 of auxiliary request 2 is thus novel within the meaning of Article 54(1) and (3) EPC.

6.6 *Inventive step*

6.6.1 An objection of lack of inventive step was raised on the basis of document D9 as closest prior art. In the drug delivery device disclosed in D9 (Figure 2), the intervener identified scale drum 30 as a "dose member" as claimed, tubular guide 40 as the "clutch member" as claimed, and knob 51 on piston rod 50 as the "stop member" as claimed (page 9, lines 4 to 21; Figure 4). In particular, protrusion 341 of scale drum 30 is deflected radially outwards by the conical portion of knob 51 (page 9, lines 16 to 21). This limited protrusion 341 results in a weak coupling which is not suitable to withstand a significant dialling torque.

6.6.2 As acknowledged by the intervener, the subject-matter of claim 1 differs from the device of D9 by feature [1.6], i.e. the clutch member and the dose member are configured to mechanically cooperate with one another when the clutch member is in the clutch stop position, thereby preventing further displacement of the dose member in the proximal direction with respect to the housing during setting of the dose.

This differentiating feature has the effect that a more precise and reliable dose limiting mechanism is provided, not requiring deformation of the dose member and/or the clutch member.

6.6.3 The intervener argued that it was obvious to modify the limiting mechanism of D9. Instead of the interaction of protrusion 341 of the scale drum 30 with the housing 20, the skilled person would provide the piston rod guide 40 with a ratchet interacting with the scale drum 30 for limiting rotation thereof. The skilled

person was aware of ratchets as an effective blocking mechanism. Therefore, feature [1.6] of claim 1 would be readily considered as the most obvious solution.

- 6.6.4 The Board remarks, however, that this argument lacks an indication of the skilled person's motivation to envision a modification of the dose limiting mechanism of D9 by providing, specifically, feature [1.6] of claim 1 without previous knowledge of the impugned patent. The amendment to the device of D9 requires changing the design of the scale drum and the guide such that a splined engagement in the last dose stop position would be permitted. This amendment would consequently make the device more bulky and would require an increased diameter of the housing 20 which is typically not desired. Consequently, the Board dismisses the argument as being based on impermissible hindsight considerations.
- 6.6.5 The opponent stated, moreover, that the skilled person would also arrive at the claimed solution without inventive step when starting from any one of D1 to D5. As no arguments were presented in this context, the Board dismisses this allegation.
- 6.6.6 The subject-matter of claim 1 of auxiliary request 2 is therefore not rendered obvious by the cited prior art. Hence, the requirements of Article 56 EPC are fulfilled. This applies, a fortiori, to the preferred embodiments of claims 2 to 14.
7. No objections were raised against the adaptation of the description.
8. The objections raised do not prejudice the maintenance of the patent on the basis of auxiliary request 2.

Order

For these reasons it is decided that:

1. The decision under appeal is set aside.
2. The case is remitted to the department of first instance, with the order to maintain the patent on the basis of:
 - claims 1 to 14 of auxiliary request 2 filed by letter dated 31 July 2018;
 - adapted description, columns 1 to 20 filed during the oral proceedings; and
 - Figures 1 to 10 of the patent as granted.

The Registrar:

The Chairman:



D. Hampe

E. Dufrasne

Decision electronically authenticated