

Internal distribution code:

- (A) [-] Publication in OJ
(B) [-] To Chairmen and Members
(C) [-] To Chairmen
(D) [X] No distribution

**Datasheet for the decision
of 26 July 2018**

Case Number: T 1353/16 - 3.2.03

Application Number: 08105923.0

Publication Number: 2083221

IPC: F24B1/02

Language of the proceedings: EN

Title of invention:

Heating apparatuses such as pellet-fired stoves and
thermostoves

Patent Proprietor:

THERMOROSSI S.P.A.

Opponents:

Cola S.r.l./Cadel S.r.l.
La Nordica S.p.A.
Caminetti Montegrappa S.r.l.

Headword:

Relevant legal provisions:

EPC Art. 83, 56

Keyword:

Sufficiency of disclosure - (yes)

Inventive step - (yes)

Decisions cited:

Catchword:



Beschwerdekammern
Boards of Appeal
Chambres de recours

Boards of Appeal of the
European Patent Office
Richard-Reitzner-Allee 8
85540 Haar
GERMANY
Tel. +49 (0)89 2399-0
Fax +49 (0)89 2399-4465

Case Number: T 1353/16 - 3.2.03

D E C I S I O N
of Technical Board of Appeal 3.2.03
of 26 July 2018

Appellant: La Nordica S.p.A.
(Opponent 2) Via Summano, 104
36030 Montecchio Precalcino (VI) (IT)

Representative: Burchielli, Riccardo
Barzano & Zanardo Roma S.p.A.
Via Piemonte 26
00187 Roma (IT)

Respondent: THERMOROSSI S.P.A.
(Patent Proprietor) Via Grumolo, 4
Zona Industriale
36011 Arsiero (Vicenza) (IT)

Representative: Feltrinelli, Secondo Andrea
APTA S.r.l.
Patent Department
Via Ca' di Cozzi, 41
37124 Verona (IT)

Party as of right: Cola S.r.l./Cadel S.r.l.
(Opponent 1) Viale del Lavoro, 7/9
Via Foresto Sud, 7
37040 Arcole (VR)/31025 Santa Lucia di Piave
(TV) (IT)

Representative: Modiano, Micaela Nadia
Modiano & Partners
Via Meravigli, 16
20123 Milano (IT)

Decision under appeal: Interlocutory decision of the Opposition
Division of the European Patent Office posted on
21 March 2016 concerning maintenance of the
European Patent No. 2083221 in amended form.

Composition of the Board:

Chairman G. Ashley
Members: C. Donnelly
D. Prietzel-Funk
B. Miller
G. Weiss

Summary of Facts and Submissions

- I. The appeal lies from the decision of the opposition division to maintain the patent EP-B-2 083 221 in amended form on the basis of auxiliary request 1 filed during the oral proceedings held on 19 January 2016.

The patent had been opposed by four parties, two of them acting jointly as opponent 1. Only opponent 2 (La Nordica S.p.A. - the "appellant") filed an appeal against this decision.

Opponent 1 (Cola S.r.l./Cadel S.r.l.) is party of as of right to the appeal proceedings under Article 107 EPC. It did not file any submissions during the appeal proceedings.

Opponent 3 (Caminetti Montegrappa S.r.l.) withdrew its opposition already during the opposition proceedings (see letter of 12 February 2015); thus it is no longer party to the proceedings.

- II. In its statement setting out the grounds of appeal the appellant cited the following state of the art:

E2.3: US 5 105 797;
E2.5: US 4 702 179,
E2.6: US 4 044 727 and
Google image search excerpt.

The respondent (patent proprietor) set out its case in its reply to the grounds of appeal by letter of 14 December 2016. It also cited:

E2.11: Technical report relating to the features of a pellet stove taught by the European Patent no. 2 083 221 B1 in the name of Thermorossi SPA, prepared by Ing. Fabio Rossi 14 January 2016.

- III. In a communication dated 16 March 2018, pursuant to Article 15(1) of the Rules of Procedure of the Boards of Appeal (RPBA), annexed to the summons to oral proceedings, the Board informed the parties of its provisional opinion.
- IV. By letter of 28 May 2018, the respondent submitted auxiliary requests 1 and 2.
- V. Oral proceedings were held on 26 July 2018. At the end of the debate the following requests were confirmed:

The appellant requested that the decision under appeal be set aside and that the European patent be revoked.

The respondent requested that the appeal be dismissed, alternatively that the patent be maintained on the basis of the claims of one of auxiliary requests 1 or 2 submitted with the letter dated 28 May 2018.

Feature analysis of claim 1

The appellant referred to the following feature analysis of claim 1 in the version which the opposition division considered could be maintained (respondent's main request).

"1. Heating pellet-fired stove and thermo-stove apparatus comprising

1.1 a substantially parallelepiped fairing (100) inside which three spaces (A, B, C) arranged side-by-side and aligned in the horizontal direction are defined,

2. said spaces (A, B, C) comprising a central space (A) and side spaces (B, C),

3. wherein the main components of the apparatus, i.e. a fuel-loading tank compartment (20), a combustion chamber compartment (10) and a smoke aspirator compartment (30) are arranged inside said spaces (A, B, C);

characterized in that:

4. the central space (A) houses the combustion chamber compartment (10) comprising a combustion chamber with a main smoke passage, an ash collector drawer, a heat exchanger and inspection openings;

5. one side space (B) houses the fuel-loading tank compartment (20) comprising the fuel storage tank, an opening for loading and a device for transporting the pellets into the furnace; and

6. the other side space (C) houses the smoke aspirator compartment (30) comprising a smoke aspirator complete with its support and a flue for the smoke coming from the combustion chamber,

7. whereby the apparatus has a bulk in which the depth dimension (K) is substantially smaller than the width and height dimension of the entire apparatus."

VI. The arguments of the parties with respect to the respondent's main request (which corresponds to auxiliary request 1 as held allowable by the opposition division) can be summarised as follows:

(a) Appellant

Insufficiency of disclosure, Article 83 EPC

The invention according to claim 1 in the version that the opposition division considered could be maintained is insufficiently disclosed since it defines that the inspection openings are housed in the central space (A). However, the inspection openings are only cited at paragraph [0020] of the patent which states:

"In an embodiment of the invention (see figs 5-6), the compartment, wholly indicated with reference numeral 10, which comprises the combustion chamber with the main smoke passage, the ash collection drawer, the heat exchanger and the inspection openings is inserted in the central space A"

However, no reference number is associated with these openings and no feature shown in the figures can be directly and unambiguously identified as these openings. Further, it is unclear what function the openings are meant to have since an inspection may be performed visually, using pressure and/or temperature using either probes or other sensors. Therefore, it is not clear how these inspections are made. Moreover, there is no technical effect or advantage.

Therefore, the skilled person cannot carry out the invention.

Inventive step, Article 56 EPC

The subject-matter of claim 1 lacks an inventive step in view of:

E2.3 in combination with the skilled person's knowledge;

E2.3 in combination with E2.5 or E2.6;

E2.6 in combination with E2.3.

E2.3 in combination with the skilled person's knowledge

E2.3 is a realistic starting out point since it discloses a stove with the same basic layout as the stove specified in claim 1. In particular, since the patent does not define any type of aspirator, the blower 65 constitutes a smoke aspirator within the meaning of the claim since it forces air into the outlet pipe 62, thereby aspirating the smoke from the combustion chamber. The illustration of the fan type device in the figures of the patent does not show that only a fan aspirator is meant since the heat exchanger arrangement is not detailed and this could in fact be a blower for room air to be heated.

Also, the door 14a and the ash-tray opening 25 as well as the vents 14b and passages 14c,14d constitute "inspection openings". Even if this is considered to be a difference, the provision of inspection openings is a trivial task for the skilled person.

Therefore, the subject-matter of claim 1 only differs from the stove disclosed in E2.3 in that:

- the smoke aspirator compartment comprising a smoke aspirator complete with its support and a flue for the

smoke coming from the combustion chamber is housed in the space on the opposite side to the space in which the fuel-loading tank compartment is housed.

The technical effect of this feature is to reduce the bulk in the depth direction. Therefore, the objective technical problem to be solved can be seen as that of providing a heating apparatus with reduced (depth) bulk such that the stove can be easily arranged in confined spaces such as corridors (see paragraph [0009] of the description of the contested patent).

When faced with this problem, the skilled person would see that, starting out from the apparatus disclosed in E2.3, in particular figure 3, a large proportion of the depth dimension is given over to various passages and compartments placed behind the combustion chamber. In particular, the combustion gas outlet 62 is positioned at the rear of the stove which not only increases the depth dimension, but also prevents the stove being placed against a wall in a corridor. As shown in the drawings handed over during the oral proceedings (see next page of the decision), the displacement of the combustion gas outlet to the side compartment comprising the fans 98 and 72 only requires a straightforward modification and is not complex. Moreover, there is no necessity to add a fan since the same aspiration method using the blower tube 65 can simply be moved to the side compartment. The skilled person would not consider moving the combustion outlet to the fuel tank side since this would contravene accepted safety practice of keeping hot gases away from fuel storage.

Simplified figure of the smoke extraction arrangement of the stove according to E2.3 submitted by the appellant during the oral proceedings before the Board.

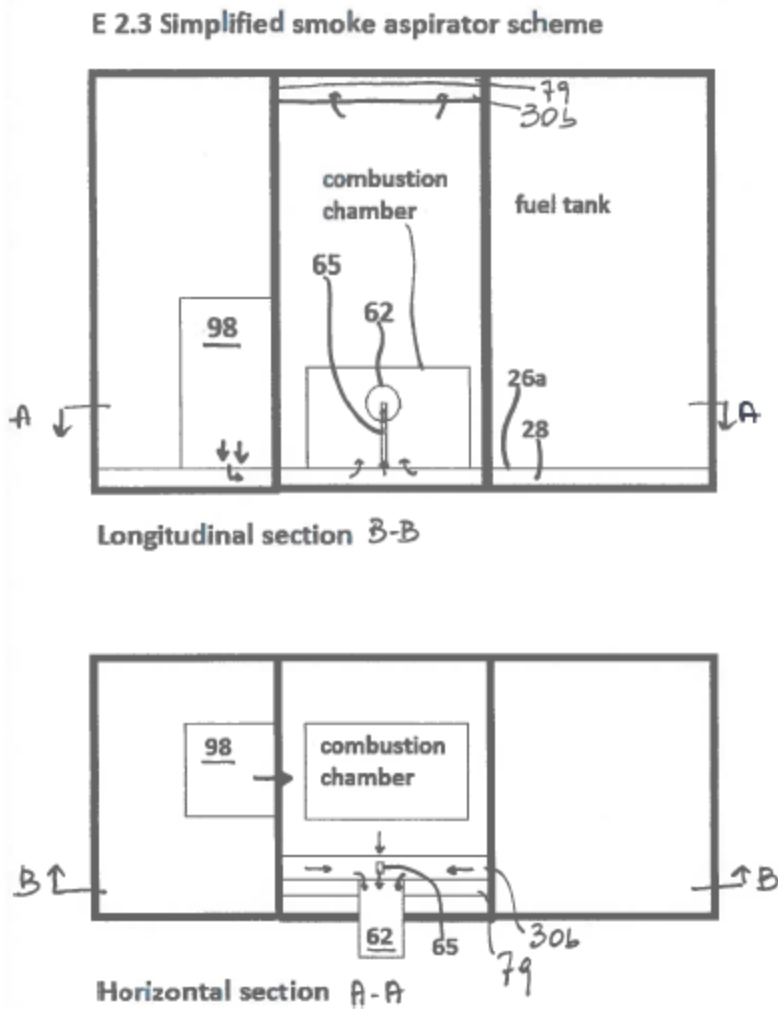

Modification to the smoke extraction arrangement proposed by the appellant during the oral proceedings

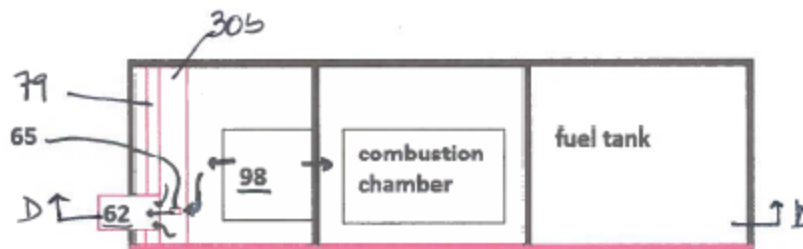
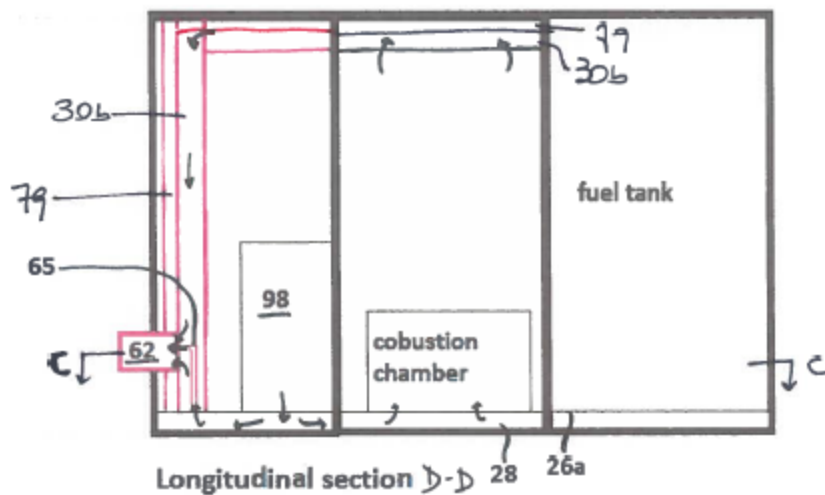

Horizontal section C-C

Alternatively, as detailed in the grounds of appeal, the skilled person would reduce the depth of the stove of E2.3 by moving the smoke aspirator compartment from the rear of the combustion chamber to the side space containing the fans as illustrated in the following figures.

As shown in the annotated copy of figure 3 of E2.3 taken from the grounds of appeal, the smoke aspirator compartment is defined as comprising the exhaust zone 30b and blower 65.

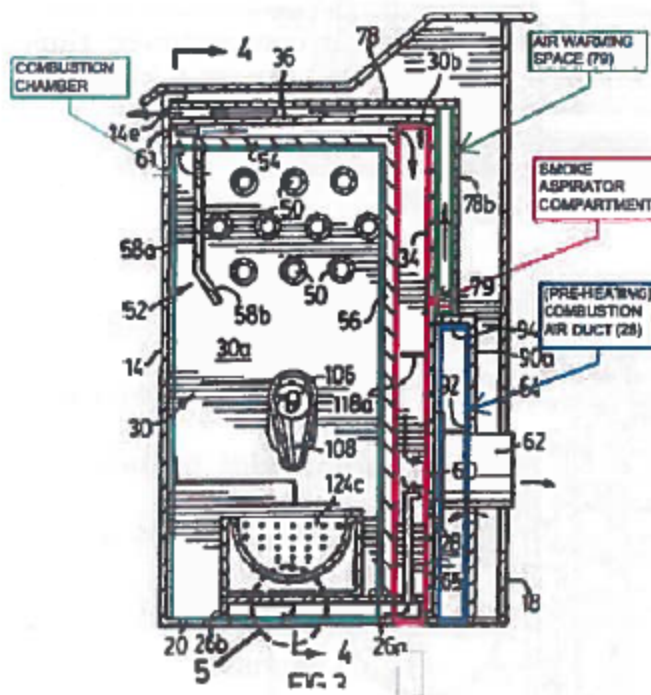

The smoke aspirator compartment can simply be relocated into the gap created in the side compartment by moving the fan assemblies laterally as shown below.

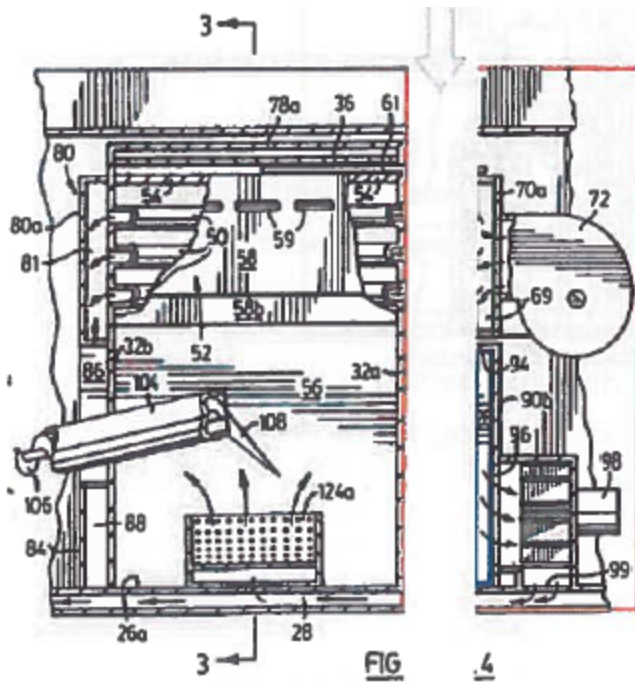

When the smoke aspirator compartment is inserted into the above gap, the modified apparatus will be configured as shown below, wherein the smoke aspirator device formed by the blower 65 is located in the side compartment opposite to the fuel-loading tank compartment. Thus, the skilled person would arrive at the subject-matter of claim 1 without exercising an inventive step.

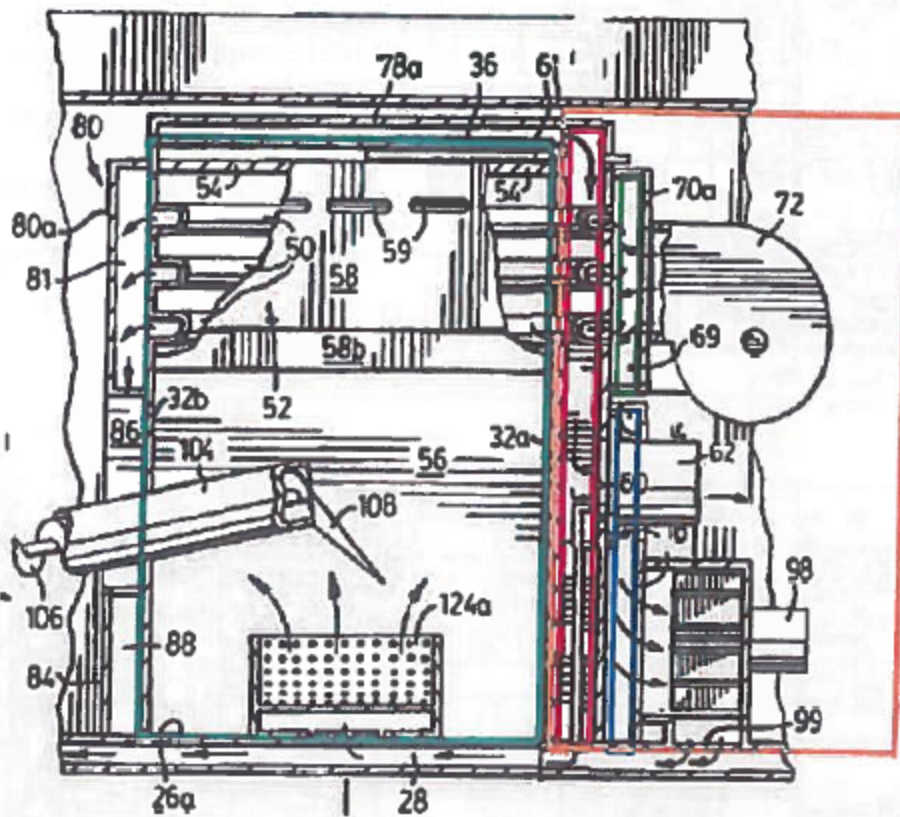

E2.3 in combination with E2.5 or E2.6

E2.5 would be consulted by the skilled person since it comes from the same technical field as the claimed invention. E2.5 also discloses a hint to place a smoke aspirator at the side of the combustion chamber. From a functional point of view, it is not important whether the aspirator is inside or outside of the casing. Therefore, E2.5 teaches the skilled person to place an aspirator in the same compartment as the other fans of E2.3.

Similarly E2.6 teaches placing a smoke aspirator (exhaust fan 19) at the side of the combustion chamber.

Starting with E2.6

E2.6 is also a suitable starting point since it only differs from the subject-matter of claim 1 in that it does not have a "fairing" or an ash-drawer and that the bulk is not specified. The skilled person faced with the problem of placing the stove of E2.6 in a confined space such as a corridor would obviously fit the device with a casing comprising three separate compartments as illustrated below.

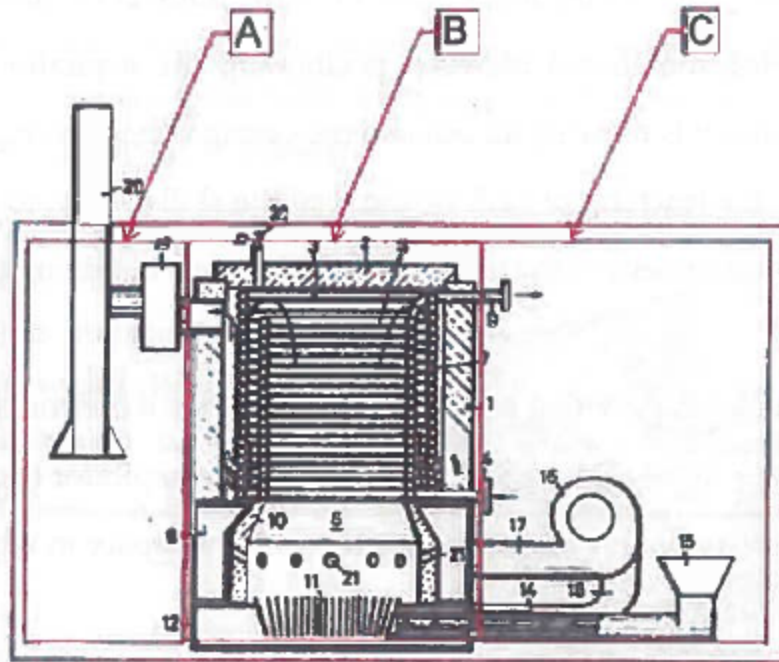

(b) Respondent

Insufficiency of disclosure, Article 83 EPC

The invention is sufficiently disclosed since the patent contains enough information about the inspection openings for the skilled man to provide them.

Inventive step, Article 56 EPC

E2.3 in combination with the skilled person's knowledge

E2.3 does not disclose that:

(a) - the combustion chamber is provided with inspection openings;

(b) the smoke aspirator compartment comprising a smoke aspirator complete with its support and a flue for the

smoke coming from the combustion chamber is housed in the space on the opposite side to the space in which the fuel-loading tank compartment is housed.

Modification suggested during the oral proceedings

The skilled person would not modify the apparatus of E2.3 as proposed by the appellant during the oral proceedings, since it would reduce the efficiency of the stove. The space 79 is intended for heating air before it exits into the room to be heated through vent 14e (see column 6, lines 10 to 14). In this arrangement the space 79 is not heated to the same extent since the inner wall of the exhaust gas passage 30b is no longer formed by the back plate 56 of the combustion zone 30a. Hence, the exhaust gases are not so hot and there is less heat transferred via the walls 34 and 36 to the space 79.

Even if the skilled person did carry out the modification, it would not result in the stove specified in claim 1 since the apparatus of E2.3 does not comprise an aspirator in the sense of the patent. The blower 65, which the appellant alleges to be an aspirator, is primarily intended to prevent ash from accumulating in the pipe 62 (see column 5, lines 44 to 49) and only assists the airflow. Fundamentally, the arrangement used in E2.3 results in an over-pressure in the combustion chamber as opposed to an under-pressure in the stove of the patent and therefore cannot be called an "aspirator".

Further, the arrangement does not provide an over-pressure in the fuel compartment, which in the apparatus of E2.3 is maintained by the blower 116 in

order to prevent combustion gases from flowing into the hopper (see column 8, lines 37 to 40).

Modification suggested in the grounds of appeal

The skilled person would also not modify the apparatus of E2.3 as proposed in the grounds of appeal since this would also reduce the efficiency of the heat exchanger. Further, the appellant has failed to explain how the combustion air and ambient air can still circulate through the respective passages in the suggested configuration. Moreover, the flue gases exit directly into the compartment comprising the fans which would result in smoke leaking into the room-space to be heated and ash being deposited in the compartment.

E2.3 in combination with E2.5 and E2.6

Both of these arguments are based purely on hindsight. The skilled person has no reason to modify the complex the air-flow arrangement of E2.3 based on the teachings of either E2.5 or E2.6.

E2.6 in combination with E2.3

The appellant's argument is also based purely on hindsight. The skilled person has no reason to combine the teachings of the two documents and no reason to fit a casing to the device disclosed in E2.6. E2.6 is in any case a less realistic starting out point than E2.3.

Therefore, on the basis of distinguishing feature (b) alone the subject-matter of claim 1 involves an inventive step.

Reasons for the Decision

1. *Insufficiency of disclosure, Article 83 EPC*

The term "inspection openings" is only mentioned once in the patent at column 2, line 50 and no reference signs have been attributed to this feature, which is not readily identifiable in the figures. However, the Board considers this to be because the provision of "inspection openings" is a trivial task for the skilled person such that when drafting the patent, it was not considered necessary to provide further detail.

Consequently, the invention is sufficiently disclosed and meets the requirements of Article 83 EPC.

2. *Novelty, Article 54 EPC*

Novelty is no longer contested in the appeal proceedings.

3. *Inventive step, Article 56 EPC, E2.3 in combination with the skilled person's knowledge*

3.1 E2.3 is the most realistic starting point since it discloses the same type of apparatus with a similar layout in which the combustion chamber is centrally located between two side spaces.

E2.3 discloses:

1. a heating pellet-fired stove and thermo-stove apparatus comprising

1.1 a substantially parallelepiped fairing ("housing 12") inside which three spaces, namely a combustion chamber 30, and sections 12a, 12b (see column 4, lines 52 to 54) arranged side-by-side and aligned in the horizontal direction are defined,

2. said spaces comprising a central space and side spaces (12a, 12b),

3. wherein the main components of the apparatus, i.e. a fuel-loading tank compartment (100), a combustion chamber compartment (30) and a smoke exhaustion compartment are arranged inside said spaces (12a,12b);

wherein

4. the central space houses the combustion chamber compartment (30) comprising a combustion chamber with a main smoke passage, an ash collector drawer (25), a heat exchanger (50) and an inspection opening (14a); and

a smoke exhaust compartment (30b) with a device to assist smoke exhaustion ("blowers 61, 65" see column 5, lines 30 to 49) and a flue (62) for the smoke coming from the combustion chamber,

5. one side space (12b) houses the fuel-loading tank compartment comprising the fuel storage tank (100), an opening for loading and a device (104,106) for transporting the pellets into the furnace;

whereby the apparatus has a bulk in which the depth dimension (K) is substantially smaller than the width and height dimension of the entire apparatus (see figure 1).

3.2 The subject-matter of claim 1 differs therefrom in that:

(a) the combustion chamber is provided with a plurality of inspection openings.

(b) the smoke aspirator compartment comprising a smoke aspirator complete with its support and a flue for the smoke coming from the combustion chamber is housed in the space on the opposite side to the space in which the fuel-loading tank compartment is housed.

3.3 There is no synergy between the two distinguishing features (a) and (b) which can therefore be handled separately when applying the problem-solution approach.

3.4 *Distinguishing feature (a)*

Inspection Openings

As reasoned above when discussing sufficiency of disclosure, providing the combustion chamber of the device according to E2.3 with a plurality of inspection openings is a trivial task for the skilled person faced with the objective technical problem of improving ease of maintenance. Also, the door 14a must certainly be considered an inspection opening since it provides direct access to the combustion chamber compartment 12 (see column 4, lines 26 to 27). This door is not covered by wire mesh as the respondent has suggested, as this would be superfluous since the door itself inhibits entry of objects into the housing interior. The mesh is only needed to overlie the vents (14b, 14e) and passages (14c and 14d) (see column 4, lines 38 to

42). The provision of a further opening would be made according to standard maintenance requirements and circumstances. E2.3 itself hints at the various options available to the skilled person since a lid 114 is provided on the fuel tank compartment 12b and access to compartment 12a can be made via the hinged cover 24.

3.5 *Distinguishing feature (b)*

3.5.1 The board agrees with the appellant that distinguishing feature (b) enables the depth dimension of the apparatus to be reduced. However, the objective technical problem should not be defined as being one of how to reduce the depth dimension of the device since this gives a hint towards the solution. In view of this the more general objective technical problem specified at paragraph [0009] of the description of the contested patent, namely to make a stove that can be easily arranged in confined spaces such as corridors, is considered to be more appropriate and would be the problem faced by the skilled person in practice.

3.6 *Type of smoke aspirator*

3.6.1 The type of smoke aspirator used in the claimed device is not detailed in the contested patent; it is merely referred to at various passages of the description as "the smoke aspirator" (see paragraphs [0013],[0015],[0019],[0020]). As argued by the respondent, in the absence of any further details, the skilled person would assume that a standard fan type of aspirator is meant. This interpretation is supported by the illustration of the aspirator compartment 30 in figure 5, showing the embodiment of the invention. This standard type of aspirator creates an under-pressure in the combustion chamber zone of the apparatus, thereby

minimising the risk that there is leakage of smoke from the device into the room where the device is located.

- 3.6.2 The patent does not explain in detail how heat from the combustion chamber is exploited, since it merely specifies that there is a heat-exchanger in the central space A (see paragraph [0020] and claim 1, feature 4). In view of this, the appellant argued that the fan illustrated in the figures could be a blower used to force air through the heat exchanger rather than an aspirator. However, this is not persuasive since the description only refers to a "smoke aspirator" to which the reference sign 30 is allocated.
- 3.6.3 The "blower" 65 used in the stove of E2.3, is not a blower in the sense of being a fan, but is a steel tube for blowing a jet of air, bled off from the combustion air duct 28 fed by the fan 98, into the outlet 62. This stream of air assists flow through outlet pipe 62 and inhibits the accumulation of ash in the pipe (see column 5, lines 44 to 46). Similarly blower 61 provides an air jet which assists flow through the exhaust zone 30b.
- 3.6.4 Therefore, the blowers 61 and 65 act as impulse jets to assist the flow of the airstream forced into the combustion zone by the fan 98 and to prevent ash deposition. Although the blowers 61 and 65 will provide a certain amount of local aspiration, this does not alter the fact that, in contrast to the stove of the contested patent, circulation of air is essentially caused by blowing, and an overpressure is maintained in the combustion zone.
- 3.6.5 Consequently, E2.3 is not considered to disclose a smoke aspirator according to claim 1.

3.7 *Feasibility of the modification to the apparatus of E2.3 as proposed by the appellant in the oral proceedings*

3.7.1 Since the air flow arrangement of the stove according to E2.3 is complex, even apparently simple modifications will result in a chain of unavoidable complications. In this case, the space 79 (see figure 3), which the appellant proposes relocating to the side compartment, is in fact connected to space 69 between the back plate 78b and the rear wall 34 (see column 6, lines 6 to 8) and not to the air inlet 92 surrounding air outlet 62, as is suggested by the drawings handed over during the oral proceedings. Further, in the arrangement of E2.3 the air-inlet 92 is connected to the fan 98 via aperture 96 in wall 90b so that air drawn into the stove via inlet 92 is directed through adjustable inlet 41 into the combustion chamber (see column 6, lines 48 to 54). It is not clear from the drawings provided by the appellant where the air intake to fan 98 is intended to be.

3.7.2 The modification proposed by the appellant also does not provide an over-pressure in the fuel compartment, which in the apparatus of E2.3 is maintained by the blower 116 in order to prevent combustion gases from flowing into the hopper (see column 8, lines 37 to 40) and which is an essential safety feature.

3.7.3 The board also agrees with the respondent that the efficiency of the stove would be affected. In the proposed modification the space 79 would not be heated to the same extent, since the inner wall of the exhaust gas passage 30b is no longer formed by the back plate 56 of the combustion zone 30a, but by a wall open to the inside of the compartment. In view of this, it is

to be expected that there would be greater heat losses leading to a greater drop in exhaust gas temperature, which in turn would lead to less heat being transferred to the air entering space 79 before it exits through vent 14e into the space to be heated (see column 6, lines 10 to 14).

3.7.4 Consequently, even if the arrangement of blower 65 with respect to the outlet 62 were considered to be a kind of aspiration device, the skilled person faced with the above objective technical problem would not consider relocating it to the side space opposite the fuel tank, as proposed by the appellant.

3.8 *Feasibility of modification to the apparatus of E2.3 proposed in the grounds of appeal*

3.8.1 In its grounds of appeal, the appellant also suggested that the apparatus of E2.3 could be modified by moving the smoke aspirator compartment (exhaust zone 30b and blower 65) to the side space containing the fans 72 and 98 as shown in the figures reproduced above.

3.8.2 This modification is considered to be neither simple nor practical. In particular, the exit of the outlet pipe 62 is shown as being directly into the compartment space between the two fans. This clearly is not a realistic proposition, since the flue gases will not exit the apparatus and may leak in to the room-space in which the device is situated. The flue gases also contain ash particles which will be deposited on the inside of the compartment (the idea behind the blower 65 is to prevent these being deposited in the pipe 62) or sucked back through air inlet aperture 92 into the fan 98.

3.8.3 Furthermore, in order for the air from the fan 72 to enter the the air-to-air heat-exchanger, the heat-exchanger tubes 50 must be extended to reach the space 70a and sealed from the relocated smoke aspirator passage 34 at the crossing points to prevent flue gases from entering the room-space to be heated via the vents.

3.8.4 In view of this, the skilled person faced with the objective technical problem of providing a stove that can be easily arranged in confined spaces such as corridors would not seek to reduce the depth dimension of the apparatus disclosed in E2.3 by carrying out the modifications suggested by the appellant.

4. *Inventive step, E2.3 in combination with E2.5 or E2.6*

4.1 E2.5 discloses a self-contained small furnace unit for coal or fuel burning. The power rating is given as 10.000 to 150,000BTU per hour (which is approximately 3 to 44KW). The size of the apparatus therefore ranges from small domestic to small commercial use. The unit is located in a housing on a concrete base (see claim 1) and is intended to be easily located inside or outside of the building to be heated (see column 2, lines 5 to 8). Coal is the main type of fuel used requiring a complex chimney arrangement to clean the flue gases (see abstract, figure A). Since the arrangement of E2.5 differs in many aspects from that of E2.3 any combination of the two documents is only possible using hindsight analysis. Further, it does not contain any suggestion to modify the apparatus of E2.3 by placing an additional extractor fan in the same space as the existing fans. In fact, the teaching of E2.5 is rather to place the extractor fan 65 outside the housing (see figures A and A1).

4.2 E2.6 discloses an apparatus for heating a heat transfer fluid flowing through concentrically arranged pipe coils arranged in a boiler casing 1. Without a plan view it is not possible to deduce the exact layout of the various components around the circular heat exchanger. None of the equipment is placed in a housing and figure 1 is entirely schematic. Since the main heat exchanger is circular there is no reason to place it in a parallelepiped housing. Therefore, E2.6 does not provide any hint to the skilled person to provide an aspirator in a side compartment of the stove of E2.3 since it does not have a side compartment and is not of a parallelepiped configuration.

5. *Inventive step, Starting with E2.6 in combination with common general knowledge or E2.3*

5.1 The board disagrees with the appellant's assertion that E2.6 is also a realistic starting point. As outlined above E2.6 without a plan view it is not possible to deduce the exact layout of the various components around the circular heat exchanger of the apparatus. Therefore, there is no reason why the skilled person would start out from an apparatus which lacks the basic configuration claimed and which in any case does not lend itself to being placed in a parallelepiped configured housing.

5.2 Therefore, the appellant's suggestion to arrange the concentric configuration of E2.6 in a parallelepiped housing according to the preamble of claim 1 is based entirely on hindsight.

6. In conclusion, the subject-matter of claim 1 in the version the opposition division considered could be maintained involves an inventive step and meets the requirements of Article 56 EPC.

Order

For these reasons it is decided that:

The appeal is dismissed.

The Registrar:

The Chairman:



C. Spira

G. Ashley

Decision electronically authenticated