

Internal distribution code:

- (A) [-] Publication in OJ
- (B) [-] To Chairmen and Members
- (C) [-] To Chairmen
- (D) [X] No distribution

**Datasheet for the decision
of 2 July 2019**

Case Number: T 0351/16 - 3.2.03

Application Number: 05732206.7

Publication Number: 1744955

IPC: A45D34/02, B05B11/00

Language of the proceedings: EN

Title of invention:
REFILL PERFUME BOTTLE

Patent Proprietor:
Beauty Union Global Limited

Opponents:
Becker-Manicure Siegfried Becker e.K.
Aptar France SAS
Bridle, Andrew
Max Time GmbH
Albéa Services
ICG Ventures

Headword:

Relevant legal provisions:

RPBA Art. 12(4)

EPC Art. 54, 56, 83, 123(2)

Keyword:

Late-filed evidence - submitted with the statement of grounds
of appeal - admitted (yes)

Novelty - (yes)

Inventive step - (yes) - non-obvious solution

Sufficiency of disclosure - (yes)

Amendments - allowable (yes)

Decisions cited:

Catchword:



Beschwerdekammern
Boards of Appeal
Chambres de recours

Boards of Appeal of the
European Patent Office
Richard-Reitzner-Allee 8
85540 Haar
GERMANY
Tel. +49 (0)89 2399-0
Fax +49 (0)89 2399-4465

Case Number: T 0351/16 - 3.2.03

D E C I S I O N
of Technical Board of Appeal 3.2.03
of 2 July 2019

Appellant: Beauty Union Global Limited
(Patent Proprietor) Unit B
19F Federal Center, 77 Sheung On Street
Chai Wan
Hong Kong (CN)

Representative: Liesegang, Eva
Boehmert & Boehmert
Anwaltspartnerschaft mbB
Pettenkoferstrasse 22
80336 München (DE)

Appellant: Albéa Services
(Opponent 5) 1 avenue du Général de Gaulle
92230 Gennevilliers (FR)

Representative: Gevers & Orès
Immeuble le Palatin 2
3-5 Cours du Triangle
92036 Puteaux La Défense cedex (FR)

Party as of right: Becker-Manicure Siegfried Becker e.K.
(Opponent 1) Friedrich-Wilhelm-Str. 18-22
42655 Solingen (DE)

Representative: Lippert Stachow Patentanwälte Rechtsanwälte
Partnerschaft mbB
Frankenforster Strasse 135-137
51427 Bergisch Gladbach (DE)

Party as of right: Bridle, Andrew
c/o Bridle Intellectual Property Limited
6F Thomas Way
Lakesview Business Park

(Opponent 3) Canterbury
Kent CT3 4JZ (GB)

Party as of right: Max Time GmbH
(Opponent 4) Rotenbachstraße 4
75334 Straubenhardt (DE)

Representative: TBK
Bavariaring 4-6
80336 München (DE)

Party as of right: ICG Ventures
(Opponent 6) 2 Koifman Street
Textile & Fashion Tower
6801294 Tel Aviv (IL)

Representative: Zimmermann, Tankred Klaus
Schoppe, Zimmermann, Stöckeler
Zinkler, Schenk & Partner mbB
Patentanwälte
Radlkoferstrasse 2
81373 München (DE)

Decision under appeal: **Interlocutory decision of the Opposition
Division of the European Patent Office posted on
27 November 2015 concerning maintenance of the
European Patent No. 1744955 in amended form.**

Composition of the Board:

Chairman G. Ashley
Members: B. Miller
G. Weiss

Summary of Facts and Submissions

- I. European patent No. 1 744 955 relates to a system comprising a perfume bottle and a refill bottle.
- II. Six oppositions were filed against the patent, based on the grounds of Article 100(b) and (c) EPC and of Article 100(a) EPC together with both Articles 54 and 56 EPC.
- III. In the interlocutory decision the opposition division found that the contested patent met the requirements of the EPC on the basis of the claims of the auxiliary request 10 filed during the oral proceedings on 20 October 2015.
- IV. This decision was appealed by the patent proprietor and by opponent 5.

As the patent proprietor and opponent 5 are appellants and respondents, whereby the remaining opponents are parties as of right in the present proceedings, for simplicity, the Board will continue to refer to the parties as the proprietor and the opponents.

- V. The proprietor requested that the decision under appeal be set aside and that the patent be maintained as granted (main request), alternatively on the basis of one of auxiliary requests I to XVI submitted with the statement setting out the grounds of appeal.
- VI. Opponent 5 requested that the decision under appeal be set a side and the patent be revoked.
Opponent 1 and opponent 4 requested that the appeal of the proprietor be dismissed.

Opponent 3 and opponent 6 did not participate in the appeal proceedings.

Opponent 2 withdrew its opposition with a letter dated 21 December 2016.

VII. Claim 1 according to the main request (claims as granted) including a feature analysis as proposed by the proprietor reads as follows:

- F1.0 "A system comprising a refill bottle (10; 100) and a regular perfume bottle (150),
- F1.1 said regular perfume bottle (150) being provided with a spraying mechanism having a stem (152),
- F1.2 said refill bottle (10; 100) being adapted to receive a liquid from said regular perfume bottle (150),
- F1.3 said refill bottle (10; 100) comprising:
 - F1.4 a bottom portion having a bottom opening (34); and
 - F1.5 an upper portion;
 - F1.6 an opening (26) provided in said upper portion wherein said opening (26) is adapted to be covered;
 - F1.7 a refill mechanism (30) provided in said bottom portion;
 - F1.8 wherein said refill mechanism (30) is provided with a check valve (32)
 - F1.8.1 that opens when said stem (152) is inserted through said bottom opening (34) and pushed to open said check valve (32),
 - F1.8.2 wherein the liquid is pushed inside said refill bottle (10; 100) through said stem (152);

Claims 2 to 9 of the main request relate to preferred embodiments of the system according to claim 1.

Claim 10 of the main request including a feature analysis as proposed by the proprietor reads:

- F10.0 "A method for refilling a refill bottle (10; 100)
- F10.1 with a liquid from a regular perfume bottle (150)
- F10.2 provided with a spraying mechanism having a stem (152),
- F10.3 said refill bottle (10; 100) comprising:
 - F10.4 a bottom portion having a bottom opening (34); and
 - F10.5 an upper portion;
 - F10.6 an opening (26) provided in said upper portion wherein said opening (26) is adapted to be covered;
 - F10.7 a refill mechanism (30) provided in said bottom portion;
 - F10.8 wherein said refill mechanism (30) is provided with a check valve (32)
 - F10.8.1 that opens when said stem (152) is inserted through said bottom opening (34) and pushed to open said check valve (32),
 - F10.8.2 wherein the liquid is pushed inside said refill bottle (10; 100) through said stem (152);
 - F10.9 said method comprising the steps of:
 - F10.9.1 inserting said stem (152) through said bottom opening (34) and pushing to open said check valve (32);
 - F10.9.2 pushing the liquid inside the refill bottle (10; 100) through said stem (152);
 - F10.9.3 receiving the liquid through said refill mechanism (30) from said regular perfume bottle (150); and
 - F10.9.4 dispensing said liquid through said opening (26)."

VIII. State of the art

The following documents cited already during the opposition proceedings were referred to by the parties in appeal proceedings:

E1: GB 2 229 380 A;
E2: DE 11 66 225 B1;
E6: DE 1 798 193 U;
E7: GB 2 095 103 A;
E10: DE 694 01 458 T2;
E12: US 4 473 097 A;
E13: US 6 533 482 B1;
E14: EP 0 855 350 A1;
E15: EP 0 626 210 A1;
E16: FR 2 073 087 A;
E17: WO 02/051283 A1;
E18: US 2002/0057938 A1;
E19: US 3 718 165 A;
E24: G 83 07 900 U1;
E29: GB 2 137 181 A;
E31: EP 1 514 492 A.

The following documents were cited for the first time in appeal

- by the proprietor:

Annex A17: concordance list between the auxiliary requests filed in appeal and opposition proceedings;
Annex A18: feature analysis of the claims as granted;
Annex A19: Article from the free online encyclopedia Wikipedia on "Aerosol";
Annex A20: Article from the free online encyclopedia Wikipedia on "Liquid";

- Annex A21: Excerpt from the Oxford English dictionary on "Liquid";
- Annex A22: Excerpt from the Oxford English dictionary on "Aerosol";
- Annex A23: Excerpt from the website www.victorinoxblog.com
- Annex A24: Excerpt from the website www.travalo.com;
- Annex A25: Red Dot Honorable Mention;
- Annex A26: Expert Report of Mr. Harold Bennett;
- Annex A27: Photos that illustrate refill solutions of competitors of the proprietor.

- by opponent 5:

- E41: DE 100 41 246 A1;
- E42: GB 2 195 296 A;
- E43: WO 96/18571 A1;
- E44: US 5 937 866 B1.

- IX. With the summons to oral proceedings, the Board sent a communication pursuant to Articles 15(1) and 17(2) of the Rules of Procedure of the Boards of Appeal (RPBA) indicating to the parties its preliminary opinion of the case.
- X. With a letter dated 18 June 2019 the proprietor filed further arguments concerning inventive step.
- XI. Opponent 1, opponent 3, opponent 4 and opponent 6 indicated with their letters dated 27 May 2019, 1 July 2019, 29 May 2019 and 28 May 2019 respectively, that they would not attend the oral proceedings.
- XII. Oral proceedings were held as scheduled on 2 July 2019 in the absence of opponent 1, opponent 3, opponent 4

and opponent 6 in accordance with Article 15(3) RPBA and Rule 115(2) EPC.

XIII. The proprietor's arguments with respect to the main request, as far as relevant for this decision, can be summarised as follows.

The subject-matter of claims 1 and 10 was directly and unambiguously derivable from figure 3 and the description from page 6, line 25 to page 7, line 2 of the application as originally filed.

Claim 1 referred to a regular perfume bottle comprising a spraying mechanism, which was suitable to push the liquid from the perfume bottle into the refill bottle. The function of the check valve was described in paragraph [0016] of the contested patent and its structure was shown in figures 1b and 2c. Hence, the contested patent contained sufficient information to rework the invention described therein.

None of the documents cited by the opponents disclosed a system comprising a refill bottle equipped with a check valve in its bottom in combination with a regular perfume bottle containing a liquid perfume composition. The expression "regular perfume bottle" according to claim 1 did not encompass a pressurized container containing any type of cosmetic formulation. The only document disclosing a perfume bottle was E1, which, however, disclosed a refill bottle, wherein the bottom did not contain a check valve.

Document E1 represented the most relevant state of the art. The subject-matter of claim 1 was not obvious when starting from the refillable atomiser disclosed therein, since E1 did not provide an incentive to use a

check valve in its refill opening. Documents E2, E6, E7, E10, E12, E14, E15, E16, E18 and E29 belonged to a different technical field such as hair care and did not suggest that a liquid perfume could be refilled by using a check valve as defined in claim 1. In particular, the check valve described in documents E2, E6, E7 and E14 was not suitable for liquids but worked only for aerosol compositions. Documents E12, E15, E16 disclosed a check valve, which could not be opened by pushing the stem of a regular perfume bottle into it. The valve according to E29 could not be used in combination with a pump spray of a regular perfume bottle. Hence, none of the cited prior art documents provided an incentive to modify the atomiser of E1 by incorporating a check valve as defined in claim 1.

XIV. The respective arguments of the opponents can be summarised as follows.

The subject-matter of claims 1 and 10 extended beyond the teaching of the application as originally filed, since the application did not teach a system in the generality as defined in the granted claims.

The contested patent did not provide sufficient information to rework the invention, since it was not explained, how the liquid could be forced from the regular perfume bottle into the refill bottle. Furthermore, it was not sufficiently described, how a check valve having the required functionality could be manufactured.

The subject-matter of claim 1 lacked novelty with regard to E1, E2, E6, E7, E14 and E31. The term "liquid" and the expression "regular perfume bottle" could not establish a distinction between the perfume

bottle according to claim 1 and a pressurised container containing an aerosol composition as described in the cited prior art.

The check valve defined in claim 1 could not be distinguished from valves described in any of documents E2, E6, E7, E10, E12, E14, E15, E16, E18, E24 and E29. The use of a well known check valve in the refill bottle known from E1 constituted an obvious modification.

Furthermore, starting from any of documents E2, E6, E7 and E14 the subject-matter of claim 1 was obvious as well, in particular when considering E1 in addition.

Reasons for the Decision

1. Admissibility of documents A19 to A27 and documents E41 to E44

Annexes A19 to A26 and documents E41 to E44 have been filed pursuant to Article 12(2) RPBA by the proprietor and opponent 5 respectively.

The admission or not of these documents into the appeal proceedings is governed by Article 12(4) RPBA.

The filing of documents E41 to E44 by opponent 5 can be seen as a reaction to the argument presented in the contested decision that a system comprising a roll-on container was not obvious. Annexes A19 to A27, in turn, were filed by the proprietor to support its arguments in regard to the interpretation of the claims adopted in the contested decision.

Therefore, the Board concludes, that these documents are not to be held inadmissible according to Article 12(4) RPBA, since they have been filed in reaction to the reasoning in the contested decision.

2. Article 100 (c) EPC - main request

2.1 Compared to the claims of the application as originally filed (reference is made to the corresponding A-publication WO 2005/101969 A1), the claim category of claim 1 has been changed from a refill bottle to a system comprising a refill bottle and a regular perfume bottle as disclosed on page 6, line 25 to page 7, line 2 and as shown in figure 3 of the application.

The application as filed does not exclude that the system comprising a perfume bottle and a refill bottle is used in combination with further components. However, such an embodiment is neither shown in the figures nor mentioned in the description. The same technical teaching is generated by the use of the term "comprising" in claim 1 of the main request which also provides the possibility that the claimed system may encompass additional further components. Since claim 1 does not define any further specific components as parts of the claimed system, it does not define subject-matter which extends beyond the teaching of the application as filed.

2.2 The arrangement disclosed in figure 3 shows a system of a perfume bottle and a refill bottle in the state of refilling. It is inherently clear from the wording of claim 1 that the spray button of the perfume bottle has to be removed before inserting its stem in the refill opening of the refill bottle.

It follows that the stem of the perfume bottle forms a conduit and that the wording of claim 1 does not exclude that the regular perfume bottle comprises a spray button in order to allow the regular use thereof.

2.3 Figures 1 and 2 of the application illustrate that a suitable refill bottle can have different means for applying the perfume, a pump spray mechanism or a roller ball, while the refilling opening in the bottom of both embodiments shown in figure 1 and 2 is the same. This is further confirmed by the teaching provided on page 7, lines 5 to 14 of the application as filed, where it is stated that the refill bottles shown in figures 1 and 2 are the same irrespective of the mechanism for spreading the liquid.

Hence the application does not teach that the system is limited to the use of the specific refill bottle shown in figure 3.

2.4 In summary, the subject-matter of claim 1 does not extend beyond the teaching of the application as originally filed.

2.5 The method of claim 10 is consistent with the system according to claim 1. Therefore the same reasoning applies with regard to the subject-matter of claim 10 as for claim 1.

2.6 Hence, the ground of opposition pursuant to Article 100 (c) EPC does not prejudice the maintenance of claims 1 to 10 of the main request.

3. Article 100 (b) EPC - main request

The contested patent describes in paragraphs [0012], [0018] and [0019] that the regular perfume bottle has a pump spray mechanism. There is no apparent reason why this pump mechanism should not be suitable to push the liquid perfume through the stem of the perfume bottle into the refill bottle.

The functionality of the check valve in the refill bottle is described in paragraph [0016] of the patent. Figures 1b and 2c of the patent further clearly illustrate how a corresponding check valve can be constructed, for example by a stem having an inner channel with an outlet hole 32 at the end, which is held down in the bottom plate of the refill bottle by a spring. It is apparent from the figures that the stem of the check valve according to figures 1b and 2c can be pushed inside the refill bottle thereby opening the outlet hole 32 of the stem to the reservoir of the refill bottle.

No technical difficulty is discernible concerning the manufacture of the valve shown in the figures of the patent.

It therefore follows, that the ground of opposition pursuant to Article 100 (b) EPC does not prejudice the maintenance of claims 1 and 10 of the main request.

4. Article 100(a) EPC in combination with Article 54 EPC - main request
- 4.1 Interpretation of claims 1 and 10 as granted
 - 4.1.1 Claim 1 refers to a system comprising a refill bottle and a regular perfume bottle.
 - 4.1.2 Contrary to the submission of the opponents, various expressions in claim 1 such as "liquid is pushed ... ", "liquid is received ... and dispensed ..." make it clear that the regular perfume bottle is not an empty bottle which is merely suitable for carrying a perfume composition but is a bottle which contains a liquid perfume composition. Moreover, a system of two empty containers would not make technically sense, since the refill bottle cannot be refilled from an empty bottle.
 - 4.1.3 The term "perfume" refers to a composition comprising a major amount of fragrances or essential oils. In a broad sense its meaning may include diluted perfume compositions such as deodorants, after shaves or eau de toilette, since the claim does not define the amount of perfume ingredients. However, the term "perfume" cannot simply be ignored and be considered to include any cosmetic formulation or any aerosol composition. For example sunscreen compositions, hair colouring compositions or hair lacquer formulations are not perfume compositions, since they do not necessarily contain perfume ingredients.
 - 4.1.4 The Board therefore concludes that the system according to claim 1 and used in the method according to claim 10 comprises a perfume bottle containing a liquid perfume composition which is a composition comprising a certain amount of perfume ingredients such as fragrances.

4.2 Novelty with regard to document E2

In point 4 of the reasons of the contested decision it is argued that claim 1 lacks novelty over E2.

E2 discloses a refill bottle which is refilled with a cosmetic aerosol composition (claim 1, figure 1).

The expression "Aerosolen, insbesondere für kosmetische Zwecke" in claim 1 of E2 refers to cosmetic aerosol compositions in general and does not inevitably disclose a perfume composition. Also the remaining description of E2 refers in general to aerosols (col. 1, line 2) or hair care (column 2, line 28) and does not disclose specifically a storage container containing a perfume composition.

Therefore the subject-matter of claims 1 and 10 differs from the system and method of refilling disclosed in E2 in that the liquid contained in the storage bottle is a perfume composition.

Since a single distinguishing feature is enough to establish novelty, it is not necessary at this point to decide whether or not

- the term "liquid" encompasses an aerosol composition

and

- the expression "regular perfume bottle" encompasses a pressurised container.

4.3 Novelty with regard to document E1

4.3.1 E1 discloses a refillable pen style perfume atomiser (see figure 4). Taking into account the statement on page 1, third paragraph of E1 concerning the problem to be solved that consumers tend to leave perfume bottles at home using them at the most morning and evening, it can be concluded that the atomiser described in E1 is used at home in combination with regular perfume bottles containing a spray mechanism.

The bottom opening of the atomiser according to E1 is sealed by a removable seal cap 12 (figures 3 and 4, last paragraph on page 1).

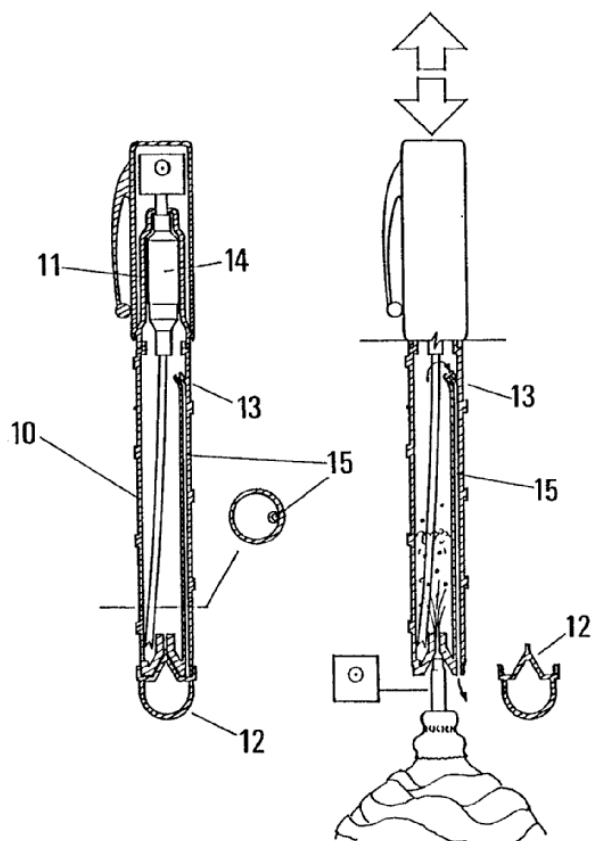

Figure 3 of E1 Figure 4 of E1

4.3.2 The atomiser comprises a check valve (one way valve 13) which allows air to pass out of the atomiser during

refilling (claim 5). Valve 13 is not located in the bottom of the refill bottle as required by claim 1 but at a side wall towards the spray mechanism of the atomiser, see figures 3 and 4. Furthermore, it does not fulfil the functionality defined in the claim 1, since the liquid cannot be received through the check valve of E1.

The atomiser according to E1 is rather filled by pressing the stem of a perfume bottle into the cone shaped opening in the bottom thereof as illustrated in figure 4 of E1.

- 4.3.3 The cone shaped opening does not inherently represent a check valve, since it does not on its own seal the perfume reservoir of the atomiser to the outside, as can be seen in figure 3. Rather, the reservoir is sealed by attaching cap 12. This is further confirmed by the statement on page 1, last paragraph: "Section 12 seals the perfume reservoir and outlet tube."

The Board therefore agrees with the reasoning in point 10.3.2 of the contested decision that the subject-matter of claims 1 and 10 differs from the system according to E1 in that the refill mechanism in the bottom of the refill bottle comprises a check valve.

- 4.4 Novelty with regard to documents E6, E7 and E14

E6 discloses a system comprising a storage bottle and a refill bottle, wherein the storage bottle contains a liquid and a propellant gas (claim 1, figure). The system according to E6 is primarily used for hair lacquer but can be used also for other cosmetics, insecticides, etc. (page 8, last paragraph).

E7 discloses a hair-dressing device comprising a pressurisable dispenser mounted to the body of the holding means (claim 1, figure 3), which can be refilled from a storage container containing a set lotion, hair lacquer or other hair care compositions such as shampoo or tonic (page 1, lines 62 to 69).

E14 discloses in claim 1 in combination with figure 1 a system comprising a refill container and a storage container. The system is suitable for dispensing cosmetic or dermo-cosmetic products in the form of a liquid, foam, gel or cream (column 1, lines 9 to 12).

The subject-matter of claims 1 and 10 differs from the systems disclosed in each of documents E6, E7 and E14 in that the liquid in the storage container is a perfume composition.

4.5 Novelty with regard to document E31 (state of the art according to Article 54 (3) EPC)

E31 discloses a system comprising a storage container having a stem 5, which can be inserted into a valve which is located in a bottom portion of a refill container, see figure 1 of E31. The stem 5 can be connected to a valve or a pump (column 5, lines 27 to 29). Alternatively the necessary pressure to pump perfume from the storage container to the refill container can be provided by applying pressure to the walls of the container (column 5, lines 36 to 41).

The use of a valve in combination with a pump or pressure applied to a wall does not inevitably result in the formation of a spray but can result in a jet or flow of liquid. To achieve a spray further means for scattering the liquid into minute droplets are

required. The formation of a spray thereby is dependent on the pressure of the liquid, its viscosity and the scattering means.

The subject-matter of claims 1 and 10 therefore differs from E31 in that the perfume bottle of the system comprises a spraying mechanism (feature 1.1).

4.6 In summary, the ground of opposition pursuant to Article 100 (a) in combination with Article 54 EPC does not prejudice the maintenance of claims 1 and 10 of the main request.

5. Article 100 (a) EPC in combination with Article 56 EPC
- main request

5.1 According to paragraphs [0003] and [0012] the contested patent relates to a system comprising a regular perfume bottle and a refill bottle, which can be carried around easily.

E1 discloses a refill perfume atomiser in the shape of a pen which can be filled by using a donor bottle (claim 1) and therefore deals with the same purpose as the contested patent.

E1 is therefore a suitable starting point for the assessment of inventive step.

5.2 As already concluded above in point 4.3, the subject-matter of claims 1 and 10 differs from the system and method for refilling according to E1 in that the refill mechanism in the bottom of the refill bottle comprises a check valve.

5.3 This difference has the effect of improved handling of the device and reduced leakage (paragraphs [0012] and [0016] of the contested patent).

5.4 The objective technical problem can therefore be seen as providing a refillable perfume bottle which allows refilling in a quick and easy manner without the risk of spilling the perfume.

5.5 It is undisputed that check valves were known in the art at the priority date of the contested patent, in particular also in the field of cosmetics and for refill systems.

However, E1 on its own does not contain any hint to modify the refill opening and in particular to make use of a check valve having the functionality defined in claim 1 as granted.

5.6 Furthermore, it has not been rendered plausible for the following reasons that any of the various documents cited by the opponents would motivate the skilled person to solve the underlying technical problem by using a check valve as defined in claim 1.

5.6.1 Documents E2, E6, E7 and E14 disclose refill containers comprising a check valve which are used for aerosols.

Aerosols are dispersions of fine particles in a gaseous phase. They are dispensed by the pressure provided by the propellant gas. The flow characteristics of an aerosol are thus similar to a gas and different from the flow characteristics of a liquid. This is the understanding of the skilled person and is confirmed in point 6 of the technical declaration of Mr. Bennet (Annex A26).

Therefore it is not immediately apparent to the skilled person that a check valve for aerosol compositions would work equally well for liquid compositions.

5.6.2 Furthermore, concerning the specific check valves disclosed in documents E2, E6, E7 and E14, it is unlikely that the skilled person would expect them to work satisfactorily with a liquid supplied by a pump mechanism of a perfume bottle, as is set out below:

a) A section of figure 1 of E2 discloses the following arrangement:

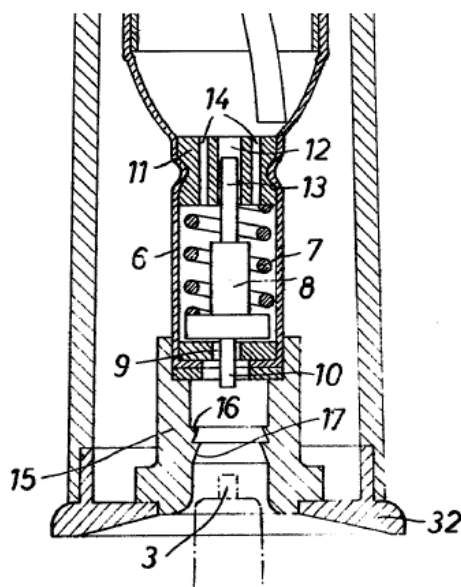

It can be expected that an gaseous aerosol composition can flow easily through the opening 9, passes through the valve housing 6 around the spring 7 and reaches the reservoir by flowing through the channels 14. However, should the valve be used in combination with a perfume bottle, the liquid perfume would be collected in the valve housing 6 and would be wasted. Moreover, the narrow channels 14 of the valve according to E2 rather create doubts that the valve can be used equally for

aerosols and liquids, since a liquid cannot be expected to flow easily and with low enough resistance through the narrow channels 14.

Hence, E2 does not provide an incentive to the skilled person to replace the refill opening in the atomiser according to E1 by the valve shown in figure 1 of E2.

b) Figure 2 of E7 discloses a further check valve 20 for an aerosol composition:

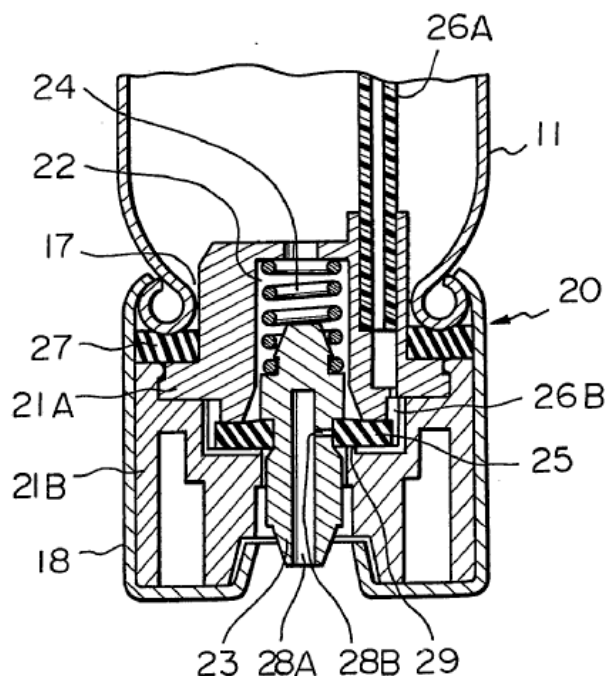

Should this valve be used in combination with a perfume bottle, the liquid would be sprayed against the head wall of the refilling channel 28A. It can be expected that most of the liquid would therefore accumulate in the refilling channel and would not pass easily through the narrow refilling channel 28B. Furthermore, liquid passing through channel 28B would fill up the valve housing in which the spring is located and would be wasted. In addition, the narrow passage 28B and the narrow passage between stem body 23 and valve housing

21A create doubts that the valve can be used equally for aerosols and liquids, similar to the reasoning indicated above with respect to the valve disclosed in E2.

Hence, E7 does not provide an incentive to the skilled person to replace the refill opening in the atomiser according to E1 by the valve shown in figure 2 of E7.

c) E14 discloses in figure 1 a further valve for aerosol compositions.

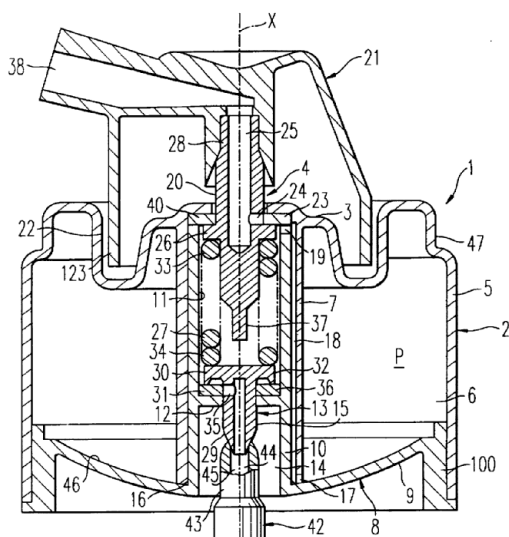

As with to the valves disclosed in E2 and E7, the valve according to E14 is not evidently suitable to be used in combination with a perfume bottle, since it can be expected that liquid would fill up the valve housing in which the spring is located and would be wasted. Furthermore, it is not apparent that a liquid could flow easily into the reservoir 6 via the narrow opening 19, the long narrow channel 18 and the recess 17.

Hence, E14 does not provide an incentive to the skilled person to replace the refill opening in the atomiser according to E1 by the valve shown in figure 1 of E14.

- d) E6 discloses a further system of pressurised containers comprising a liquid and a propellant gas. E6 does not disclose any details of the check valve, nor teaches that the check valve 4 shown in the figure is suitable for liquids.

Therefore E6 does not provide any hint to the skilled person that the check valve described therein could be used in an atomiser according to E1.

- 5.6.3 Documents E10, E12, E15 and E16 disclose refill containers comprising check valves that are suitable for use with liquids.

According to feature F1.8.1 of claim 1 the refill bottle has a check valve

"that opens when said stem (152) is inserted through said bottom opening (34) and pushed to open said check valve (32)".

Thus, claim 1 requires *expressis verbis* that the valve has to be suitable to be opened by inserting and pushing the stem of the perfume bottle into the valve.

This functionality required according to claim 1 is not provided by the check valves disclosed in documents E10, E12, E15 (patent family member of E10) and E16 as evident from the following exemplary figures of these documents.

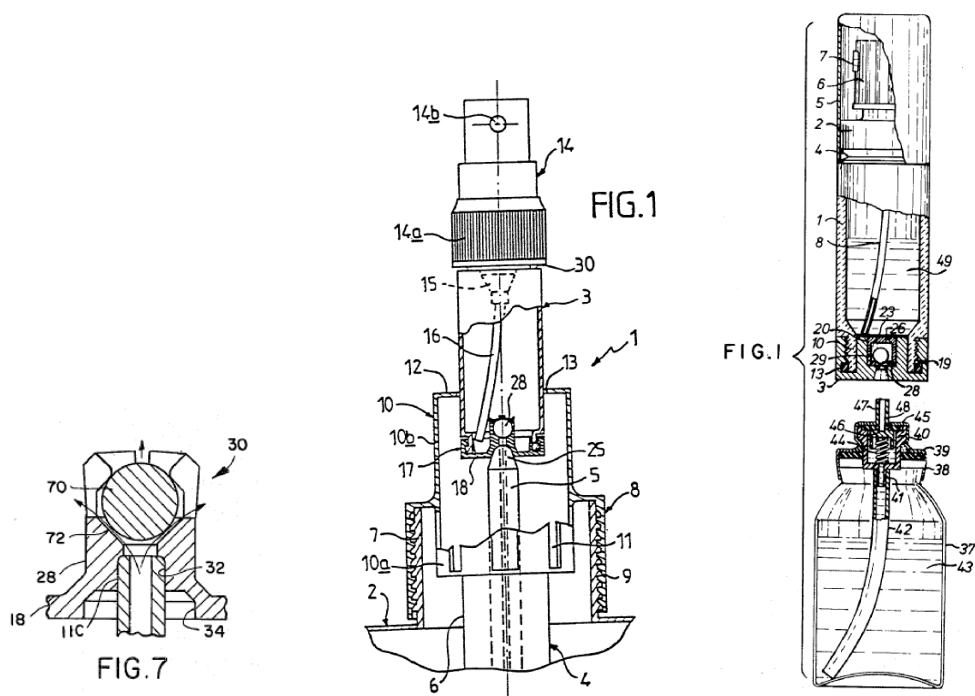

figure 7 of E12 figure 1 of E10/E15 figure 1 of E16

The ball closing the check valve according to each of documents E10, E12, E15 and E16 cannot be opened by the stem of the storage bottle, but rather is opened by the pressure applied by the product flowing into the valve. This is shown in detail, for example, by the arrows in figure 7 of E12.

Therefore, documents E10, E12, E15 and E16 do not show a check valve according to feature F1.8.1 of claim 1 which can be opened by inserting and pushing the stem of the perfume bottle into the valve, and consequently do not provide a hint to the skilled person to use a check valve as defined in claim 1 in an atomiser according to E1.

5.6.4 E18 discloses in paragraph [0136] in combination with figures 7 to 9 a check valve in a refillable container, which is opened by the pressure of the product, similar to the check valve described in E10, E12, E15 and E16.

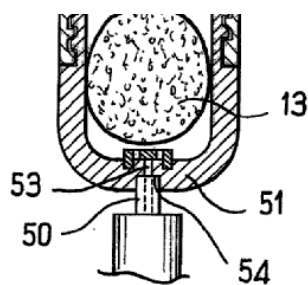

FIG. 9

section of figure 9 of E18

The same type of check valve is also used in further embodiments according to E18, for example in the container described in paragraph [0180] in combination with figures 17 and 18.

Hence, also document E18 does not provide a hint to the skilled person to use a check valve as defined in claim 1 in an atomiser according to E1.

5.6.5 Document E24 and its patent family member E29 show in figures 1 and 3 a refill bottle comprising two sealing lips 7 in its bottom forming a check valve.

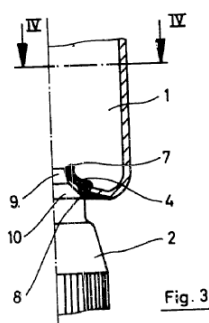

figure 3 of E29

This valve is opened by inserting a stem of a perfume bottle as required by claim 1 of the contested patent. However, once the stem of the perfume bottle has been inserted into a valve according to E24/E29, in the absence of any resistance provided by the opened lips 7, the stem cannot be pushed down to actuate the pump spray mechanism of a perfume bottle for transferring

the perfume from the perfume bottle into the refill container. The valve of E24/E29 cannot function in this way and hence E24/E29 would not be considered by the skilled person for further modification starting from the disclosure of E1.

5.7 In summary, starting from document E1 the subject-matter of claims 1 and 10 is not obvious in view of the further documents presented in appeal proceedings.

5.8 Concerning the assessment of inventive step starting from E2, E6, E7 and E14 the following is concluded.

E2 (claim 1) and E14 (claim 1) are directed to a refillable container for cosmetic aerosol compositions. E6 (page 2, first paragraph) and E7 (claim 1) relate to pressurized hair care products. Hence, each of documents E2, E6, E7 and E14 deals with a different purpose than the contested patent, and is less relevant than E1 and does not provide a more suitable starting point than E1 for the assessment of inventive step.

Even if the skilled person were to start from any these documents, no reason can be found by the Board, why it would expect that a refill bottle for aerosols could be used in combination with a regular perfume bottle containing a liquid, in particular in view of the arguments indicated above in point 5.6.

Hence it is concluded that the subject-matter of claims 1 and 10 is not obvious when starting from any of documents E2, E6, E7 and E14.

5.9 The ground of opposition pursuant to Article 100 (a) in combination with Article 56 EPC therefore does not

prejudice the maintenance of claims 1 and 10 of the main request.

Order

For these reasons it is decided that:

1. The decision under appeal is set aside.
2. The patent is maintained unamended.
3. The appeal of opponent 5 is dismissed.

The Registrar:

The Chairman:



C. Spira

G. Ashley

Decision electronically authenticated