

Internal distribution code:

- (A) [-] Publication in OJ
- (B) [-] To Chairmen and Members
- (C) [-] To Chairmen
- (D) [X] No distribution

**Datasheet for the decision
of 28 October 2016**

Case Number: T 1698/15 - 3.2.02

Application Number: 10004383.5

Publication Number: 2380507

IPC: A61B17/11

Language of the proceedings: EN

Title of invention:

Sleeve-type fixing method and device for anastomosis for tubular organs such as intestines, stomach, esophagus

Patent Proprietor:

Liu, Zhongchen

Opponent:

Carponovum AB

Headword:

Relevant legal provisions:

EPC R. 99

RPBA Art. 12(4)

EPC Art. 111(1)

Keyword:

Admissibility of appeal - (yes)

Admissibility of the only request (yes)

Reason for revocation overcome (yes)

Remittal to the department of first instance - (yes)

Decisions cited:

J 0022/86, T 1708/08, T 0655/13

Catchword:



Beschwerdekammern
Boards of Appeal
Chambres de recours

European Patent Office
D-80298 MUNICH
GERMANY
Tel. +49 (0) 89 2399-0
Fax +49 (0) 89 2399-4465

Case Number: T 1698/15 - 3.2.02

D E C I S I O N
of Technical Board of Appeal 3.2.02
of 28 October 2016

Appellant:
(Patent Proprietor)

Liu, Zhongchen
Room 302
No.192 Yuxiuli
Xiamen
Fujian (CN)

Representative:

Garavelli, Paolo
A.BRE.MAR. S.R.L.
Consulenza in Proprietà Industriale
Via Servais 27
10146 Torino (IT)

Respondent:
(Opponent)

Carponovum AB
Kristinebergsvägen 22
302 41 Halmstad (SE)

Representative:

Ström & Gulliksson AB
P.O. Box 4188
203 13 Malmö (SE)

Decision under appeal:

**Decision of the Opposition Division of the
European Patent Office posted on 22 June 2015
revoking European patent No. 2380507 pursuant to
Article 101(3) (b) EPC.**

Composition of the Board:

Chairman E. Dufrasne
Members: P. L. P. Weber
D. Ceccarelli

Summary of Facts and Submissions

- I. The appeal of the patent proprietor is against the decision of the Opposition Division, posted on 22 June 2015, revoking the patent because of lack of clarity of claim 1 of the sole request on file. Claim 1 on file was based on a combination of claims 1 to 5 of the patent as granted.
- II. After the filing of the notice of opposition, the patent proprietor filed an amended set of claims on 3 January 2014. In a reply dated 20 March 2014 the opponent argued inter alia that claim 1 was not clear for the same reason as that invoked in the impugned decision.
- III. The only reasoning present in the decision under appeal in this respect is the following:
"The subject-matter of claim 1 is not regarded as being clear (Article 84 EPC) for the following reason: The wording "... both the outer ring (2) and the intestine (4) fixed on said outer ring (2) ..." and "... the adventitia (3,4) of the intestines fixed on the rings ..." is such, that the intestines are connected to the outer ring and hence form part of the claimed subject-matter. This is not clear, as the intestines, when the device is used for an anastomosis operation, are part of the patient and cannot therefore form part of the claimed subject-matter. Hence, the scope of protection of claim 1 is not clear in the sense of Article 84 EPC."
- IV. The impugned decision was taken in oral proceedings held on 5 May 2015 in the absence of the patentee due to sickness, as announced by fax on 4 May 2015.

- V. The notice of appeal was filed on 21 August 2015 and the appeal fee paid on the same date. In the notice of appeal the following can be read:

"...we are filing a NOTICE OF APPEAL against the Decision to refuse European Patent Application No. 10004383.5 dated 22.06.2015 and notified to us on 25.06.2015.

Applicant:
Liu Zhongchen
(...)

REQUESTS

It is requested that the above Decision be set aside and that European Patent Application No. 10004383.5 be granted. (...)"

- VI. The statement setting out the grounds of appeal was filed on 12 October 2015. The following can be read in it:

"(...) The Decision to refuse was based only on a supposed Lack of Clarity according to Article 84 EPC, but it is clear from the description and from the common sense, that the intestines cannot form part of the claimed subject matter. The wording as cited, namely "fixed", only and clearly means that, when the intestines are fixed on the outer ring, they follow the behaviour and movement of the outer ring itself: this is clear from description and drawings and cannot cause any misunderstanding about the scope of the invention.

A New Set of Claims including a New Claim 1 is also filed concurrently with the above comments, to show that the wording of New Claim 1 is in compliance with

originally granted Claim 1, is only slightly different from the previous Claim 1 and finds its base in the description as filed: in this New Claim 1, both clarity problems and possible objections raised in the Opposition about formal contents of the Claim, have been dealt with, as formal statement of the scope of the invention.

Since the prior art as commented in the Opposition has no relevance with the current invention, disclosing other types of devices which cannot be combined together, it is requested to confirm the New Set of Claims (derived from the description as filed) as novel and inventive."

- VII. In its reply dated 19 February 2016 the respondent/opponent considered that the appeal was not admissible.
- VIII. In a communication dated 13 June 2016 the Board informed the parties that it considered the reason given in the impugned decision for revoking the patent to no longer apply to the request on file, and that it intended to remit the case to the department of first instance for further prosecution.
- IX. In a reply dated 25 July 2016 the respondent/opponent informed the Board that it did not agree with a remittal of the case, and explained why.
- X. With communication dated 4 August 2016, the Board summoned the parties to oral proceedings.
- XI. With letter dated 11 August 2016 the appellant/patent proprietor informed the Board that it would not be attending the oral proceedings, and that it agreed with the provisional conclusions of the Board.

XII. In a letter dated 21 September 2016 the respondent/opponent filed additional arguments to defend its position. In particular, it raised additional lack-of-clarity objections and objections under Article 123(2) and (3) EPC.

XIII. Oral proceedings were held on 28 October 2016.

The appellant/patent proprietor had requested in writing that the decision under appeal be set aside and that the patent be maintained on the basis of claims 1 and 2 filed with letter dated 1 October 2015.

The respondent/opponent requested that the appeal be dismissed.

Furthermore, the respondent/opponent requested that the appeal be rejected as inadmissible, that the new set of claims not be admitted into the appeal proceedings and that the case not be remitted to the department of first instance for further prosecution.

XIV. The different versions of claim 1 read as follows:

Claim 1 of the patent as granted reads as follows:

"Sleeve-type fixing device for anastomosis for tubular organs, such as for intestines, stomach, esophagus, comprising an inner ring (1) and an outer ring (2), wherein said outer ring (2) is made of elastic material, said outer ring (2) and said inner ring (1) are adapted to be sewed to two intestines ends (3, 4) and to be fixed to the two intestine ends (3, 4) on an external part of the outer ring (2) and the inner ring (1)

characterised in that the outer ring (2) when the intestine (4) is fixed to said outer ring (2) is adapted to be overturned so that the intestine (4) is connected to the inside of the outer ring (2), the outer ring (2) and the inner ring (1) and the adventitia (3, 4) of the intestines when fixed on the rings (1, 2) being adapted to be clamped together."

Claim 1 on which the decision under appeal is based reads as follows:

"Sleeve-type fixing device for anastomosis for tubular organs, such as for intestines, stomach, esophagus, comprising an inner ring (1) and an outer ring (2), wherein said outer ring (2) is made of elastic material, said outer ring (2) and said inner ring (1) are adapted to be sewed to two intestine ends (3, 4) and to be fixed to the two intestine ends (3, 4) on an external part of the outer ring (2) and the inner ring (1)

characterised in that

- both the outer ring (2) and the intestine (4) fixed on said outer ring (2) are adapted to be overturned so that the intestine (4) is connected to the inside of the outer ring (2), the outer ring (2) and the inner ring (1) and the adventitia (3, 4) of the intestines fixed on the rings (1, 2) being adapted to be clamped together;
- the upper portion (13) of said inner ring (1) is used for anastomose, the middle portion (12) is used for connecting, and the lower portion (11) is used for insertion, the diameter of the connecting portion (12) being smaller than the diameter of the insertion portion (11) and of the anastomose portion (13);

- the inside of the lower portion of the outer ring (2) has an inwardly protruding ring (21);
- said insertion portion (11) of said inner ring (1) is provided with axial grooves (112); and
- the bottom of the insertion portion (11) is provided with barbs (111)."

Claim 1 as filed with the statement setting out the grounds of appeal reads as follows:

"Sleeve-type fixing device for anastomosis for tubular organs, such as for intestines, stomach, esophagus, comprising an inner ring (1) and an outer ring (2), wherein said outer ring (2) is made of elastic material, said inner ring (1) is adapted to be sewed and fixed to a first intestine end (3) on an outside of an anastomosis portion of said inner ring (1), said outer ring (2) is adapted to be sewed and fixed to a second intestines end (4), characterised in that:

- the outer ring (2), when the second intestines end (4) is fixed on said outer ring (2), is adapted to be overturned so that the second intestines end (4) is connected to an inside of the outer ring (2), the outer ring (2), the inner ring (1) and the first and second intestines ends (3, 4), when fixed on the inner and the outer rings (1, 2), being adapted to be clamped together;
- an upper portion (13) of the inner ring (1) is used for anastomose, a middle portion (12) is used for connecting, and a lower portion (11) is used for insertion, a diameter of the connecting portion (12) being smaller than a diameter of the insertion portion (11) and of the anastomose portion (13);
- an inside of the lower portion of the outer ring (2) has an inwardly protruding ring (21);

- said insertion portion (11) of said inner ring (1) is provided with axial grooves (112) to enable a diameter of the insertion portion (11) to be variable and narrowing; and
- a bottom of the insertion portion (11) is provided with barbs (111) adapted to prevent the outer ring (2) from being separated from the inner ring (1)."

XV. The arguments of the respondent/opponent relevant for the present decision are summarised as follows:

Admissibility of the appeal

The appeal was not admissible because the decision under appeal was not identifiable and there was no clear request on file. Words such as "refuse", "application" and "granting" were used in the notice of appeal and the statement setting out the grounds of appeal, which were indicative of a decision concerning an application, not a granted patent. Moreover, the status (main or auxiliary) of the filed claim request was not defined either, since the appellant/patent proprietor seemed to be referring first to the revoked patent and then to the new set of claims.

Admissibility of the new set of claims

The new set of claims was not to be admitted into the proceedings because the lack-of-clarity objection on which the decision under appeal was based had been on file for a long time before the oral proceedings in the opposition proceedings, so that the appellant/patent proprietor had had time enough to deal with it before filing the appeal.

Remittal

There should be no remittal; the appellant/patent proprietor should not be given extra opportunities to correct or redo what she had not done in the first-instance proceedings.

- XVI. The arguments of the appellant/patent proprietor relevant for the present decision are essentially those underlying the reasons for this decision as set out below.

Reasons for the Decision

1. The invention is about a device combining two rings usable for anastomosis of tubular organs such as intestines. In use, one of the rings, the inner ring, is fixed to one free end of the intestine, and the other ring, the outer ring, is fixed to the other free end of the intestine and then "overturned". Finally the inner ring with the one end of the intestine is inserted into the outer ring on which the other end of the intestine is fixed so that the two ends of the intestine are in contact, can heal and join together.

This is best seen in Figure 9 of the patent:

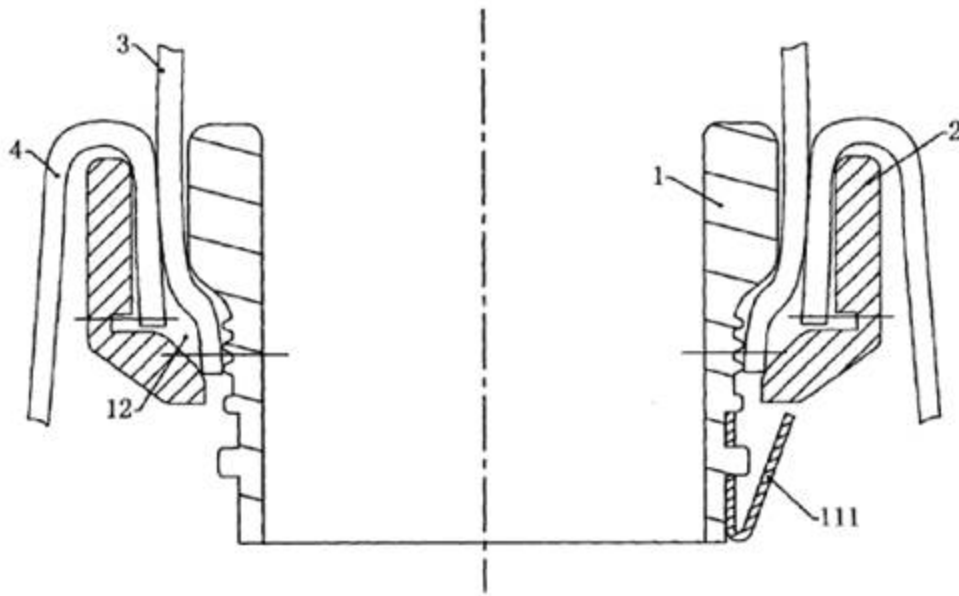

FIG.9

2. Admissibility of the appeal

The respondent/opponent submitted that the appeal was not admissible because the decision under appeal was not identifiable and there was no clear request on file since the appellant/patent proprietor talked about "application" and "granting" and not maintenance as granted or in amended form. By using such vocabulary it was even unclear whether the appellant/patent proprietor possibly wished to file an appeal against a decision of the Examining Division, which had also objected to the clarity of the claims. Further, it was not clear what the status of the new set of claims was, i.e. whether it constituted a main request or an auxiliary request. This was not clear from the statement setting out the grounds of appeal since the appellant/patent proprietor first seemed to address the revoked request before arguing about the new set of claims. According to the established case law, the requests had to be unambiguously formulated.

2.1 According to the established case law of the boards of appeal, the elements necessary for an appeal to be admissible, if not present explicitly, must at least be present implicitly.

2.2 As can be seen from the above (point V), the notice of appeal mentions the application number together with the date of the impugned decision and the name of the applicant (or patent proprietor). It appears that the date of the impugned decision is the date of the decision of the Opposition Division revoking the patent based on the mentioned application number and having the same proprietor. According to the Board, it follows from the above that even though the appellant/patent proprietor improperly used the wording "... *decision to refuse the ... application...*" and "... *that European Patent Application ... be granted.*" it is clear that the appellant/patent proprietor meant to appeal against the decision of the Opposition Division of the 22 June 2015 to revoke the patent and that, consequently, she is requesting the maintenance of the patent.

Thus, the necessary elements allowing identification of the decision under appeal are present in the notice of appeal.

2.3 The appellant/patent proprietor filed a new set of claims with her statement setting out the grounds of appeal. Claim 1 defended by the appellant/patent proprietor in the opposition proceedings and on which the decision was based, as well as claim 1 of the new set of claims, are a combination of claims 1 to 5 of the patent as granted with slight amendments, so that for this reason alone it seems clear that the

appellant/patent proprietor is not seeking the maintenance of the patent as granted.

However, it could still possibly be questioned whether the appellant/patent proprietor wants the patent to be maintained on the basis of the same request as that revoked by the Opposition Division, and only as an auxiliary measure is seeking maintenance of the patent on the basis of the new set of claims.

In the Board's opinion it is clear that the new set of claims should form the basis for deciding on maintenance.

Indeed in the second paragraph of the statement setting out the grounds of appeal (point VI above) the appellant/patent proprietor states that "*it is clear from the description and from the common sense, that the intestines cannot form part of the claimed subject-matter*", and this appears to have been corrected in the new set of claims. This new set of claims is said to be "*filed concurrently with the above comments, to show that the wording (...) is in compliance with originally granted Claim 1*", which is an indication that it is meant to address the problem. Moreover, in the last paragraph of the statement setting out the grounds of appeal it is stated that "*it is requested to confirm the New Set of Claims (...) as novel and inventive*", which appears to be a clear indication that the new set of claims constitutes the only request of the appellant.

Thus, it appears at least implicit from the statement setting out the grounds of appeal that the new set of claims should form the basis for maintaining the patent in amended form.

2.4 From the only reasoning present in the decision under appeal (point III above) in respect of the clarity objection that led to the revocation of the patent it follows that the only reason for revoking the patent was that the intestines were considered to form part of the claimed subject-matter together with the rings in the feature:

"both the outer ring (2) and the intestine (4) fixed on said outer ring (2) are adapted to be overturned so that the intestine (4) is connected to the inside of the outer ring (2), the outer ring (2) and inner ring (1) and the adventitia (3, 4) of the intestines fixed on the rings (1, 2) being adapted to be clamped together;"

In claim 1 of the new set of claims filed with the statement setting out the grounds of appeal this feature reads:

"the outer ring (2), when the second intestines end (4) is fixed on said outer ring (2), is adapted to be overturned so that the second intestines end (4) is connected to an inside of the outer ring (2), the outer ring (2), the inner ring (1) and the first and second intestines ends (3, 4), when fixed on the inner and the outer rings (1, 2), being adapted to be clamped together;" (emphasis added).

This wording with "when" was present in claim 1 of the patent as granted and clarifies that the intestines do not form part of the claimed subject-matter.

Hence, it is also self-evident that this amendment overcomes the sole reason for revocation in the decision under appeal, making further explanations in

this regard unnecessary (e.g. T 0655/03, T 1708/08, J 0022/86 (OJ EPO 1987,280)).

- 2.5 Consequently, it appears that the decision under appeal is identifiable, that it is clear what the request of the appellant/patent proprietor is, and a full reasoning as to why claim 1 of the new set of claims on file overcomes the single reason for revocation is not necessary, with the result that the notice of appeal and the statement setting out the grounds of appeal fulfil the requirements of Rule 99 EPC.

Hence, the appeal is admissible.

3. Admissibility of the new set of claims

The respondent/opponent considered that the new set of claims should not be admitted into the proceedings because not only was the same objection as in the reasons for the decision already addressed in the examining phase but the respondent/opponent had also addressed it in its reply of 20 March 2014 more than a month before the planned oral proceedings in the opposition proceedings. Thus, the appellant/patent proprietor knew about the objection and had plenty of time to deal with it. She should not be allowed to concentrate on it only by filing an amended request in the appeal proceedings. Article 12(4) RPBA had to be applied and the request had to be held inadmissible because the appellant/patent proprietor could have filed it earlier in the first-instance proceedings.

While it is not frequent that the Opposition Division and later on the Board of Appeal have to decide on a single request, it is up to the patent proprietor (with her representative) to decide how she defends her case.

Of course, she could have filed an auxiliary request dealing with the clarity objection already in the written phase of the opposition proceedings, but she might possibly have been convinced that the Opposition Division would decide in her favour after hearing her, or she might have intended to file it during the oral proceedings, which she was unable to attend because her representative was ill. In any case it is established case law that a losing patent proprietor can in principle defend its case in appeal by filing a new request, which is what she has done here. And she did so at the earliest time possible in the appeal proceedings, namely with the filing of the statement setting out the grounds of appeal. In addition, as already mentioned above, it clearly addressed the objection that led to revocation.

Therefore, in the present case, the Board considers that it would not be appropriate to exercise its discretion according to the first part of Article 12(4) RPBA (...the power of the Board to hold inadmissible ... requests which could have been presented ... in the first-instance proceedings...) in order to dismiss the request, because this would result in a disproportionate outcome, namely the definitive revocation of the patent in the special situation in which the appellant/patent proprietor could not file that request at the first-instance oral proceedings because her representative was ill, but then did so at the earliest possible time afterwards.

Hence, the new set of claims is admitted into the appeal proceedings.

4. Remittal

Following the Board's communication to the parties, indicating that it intended to remit the case to the department of first instance for further prosecution, the respondent/opponent objected because that would give the appellant/patent proprietor an opportunity to correct her own negligence, and an opportunity to redo the first-instance oral proceedings.

In the present case, considering that the appellant/patent proprietor did not have chance to defend her case in oral proceedings at first instance because her representative was ill, that the objection on which the revocation was based has been overcome, that the respondent/opponent and the appellant/patent proprietor will have every opportunity to defend their cases before two instances, and finally also that the case has been dealt with swiftly in appeal proceedings so that the length of the proceedings is not seriously affected, the Board is of the opinion that an immediate remittal pursuant to Article 111(1) EPC is the most appropriate procedural step.

Order

For these reasons it is decided that:

1. The decision under appeal is set aside.
2. The case is remitted to the department of first instance for further prosecution.

The Registrar:

The Chairman:



D. Hampe

E. Dufrasne

Decision electronically authenticated