

**Internal distribution code:**

- (A) [ - ] Publication in OJ
- (B) [ - ] To Chairmen and Members
- (C) [ - ] To Chairmen
- (D) [ X ] No distribution

**Datasheet for the decision  
of 10 April 2019**

**Case Number:** T 0673/14 - 3.2.02

**Application Number:** 08774646.7

**Publication Number:** 2173410

**IPC:** A61B5/145, A61M5/158, A61M5/32,  
A61B5/15

**Language of the proceedings:** EN

**Title of invention:**  
INSERTER HAVING TWO SPRINGS

**Patent Proprietor:**  
Unomedical A/S

**Opponents:**  
Roche Diagnostics GmbH  
Roche Diabetes Care AG

**Headword:**

**Relevant legal provisions:**  
EPC Art. 83, 54, 56

**Keyword:**

Sufficiency of disclosure (yes)

Novelty (yes)

Inventive step (yes)

**Decisions cited:**

**Catchword:**



**Beschwerdekammern**  
**Boards of Appeal**  
**Chambres de recours**

Boards of Appeal of the  
European Patent Office  
Richard-Reitzner-Allee 8  
85540 Haar  
GERMANY  
Tel. +49 (0)89 2399-0  
Fax +49 (0)89 2399-4465

Case Number: T 0673/14 - 3.2.02

**D E C I S I O N**  
**of Technical Board of Appeal 3.2.02**  
**of 10 April 2019**

**Appellant:** Roche Diagnostics GmbH  
(Opponent 1) Sandhoferstr. 116  
68305 Mannheim (DE)

**Representative:** Rentsch Partner AG  
Bellerivestrasse 203  
Postfach  
8034 Zürich (CH)

**Respondent:** Unomedical A/S  
(Patent Proprietor) Birkerød Kongevej 2  
3460 Birkerød (DK)

**Representative:** D Young & Co LLP  
120 Holborn  
London EC1N 2DY (GB)

**Party as of right:** Roche Diabetes Care AG  
(Opponent 2) Kirchbergstr. 190  
3400 Burgdorf (CH)

**Representative:** Rentsch Partner AG  
Bellerivestrasse 203  
Postfach  
8034 Zürich (CH)

**Decision under appeal:** **Interlocutory decision of the Opposition  
Division of the European Patent Office posted on  
20 January 2014 concerning the maintenance of  
European Patent No. 2173410 in amended form.**

**Composition of the Board:**

<b>Chairman</b>	E. Dufrasne
<b>Members:</b>	M. Stern
	D. Ceccarelli

## **Summary of Facts and Submissions**

- I. One of the opponents (opponent 1) lodged an appeal against the decision, posted on 20 January 2014, concerning the maintenance of European patent No. 2 173 410 in amended form.
- II. Notice of appeal was filed on 18 March 2014, and the fee for appeal was paid the same day. A statement setting out the grounds of appeal was received on 19 May 2014.
- III. The following documents are relevant for the present decision:
- D1: WO-A-2004/098683  
D2: WO-A-2005/046780  
D3: US-A-2004/0133164  
D8: US-A-2007/0093754
- IV. Oral proceedings were held on 10 April 2019.

The appellant (opponent 1) requested that the decision under appeal be set aside and that the patent be revoked.

The respondent (patent proprietor) requested that the decision under appeal be set aside and that the patent be maintained on the basis of one of the main request, filed during the oral proceedings, auxiliary requests I to IV filed with a letter dated 29 September 2014 and auxiliary requests V to XI filed with a letter dated 7 March 2019.

No request was presented during the entire appeal proceedings by the party as of right (opponent 2).

V. Claim 1 of the main request reads as follows:

"An inserter for a medical device comprising

- a house (1),
- two elastic elements (11, 12) where activation of the first elastic element (11) cause a penetrating member (6A) to be inserted sub- or transcutaneously into the skin of a patient, and the second elastic element (12) cause the penetrating member (6A) to be retracted from the skin of the patient where the first elastic element (11) is in an unloaded state before activation and upon activation the first elastic element (11) energizes the second elastic element (12),
- a stationary part (10) being stationary in relation to the patient during insertion and resting against the patients skin,
- activation means (1),
- a carrier body (2) which carrier body (2) has a forward and a retracted position relative to the stationary part (10) and
- a needle hub (6) connected with a penetrating member (6A),
- first locking means (4) locking the carrier body (2) in a retracted position,
- first release means (13A) unlocking the carrier body (2) from a retracted position, the first elastic element (11) applies force to a surface of the house (1) and to a surface of the carrier body (2) and the second elastic element (12) applies force to a surface of the needle hub (6) and a surface of the stationary part (10),

characterized in that it comprises second locking means (8, 9) locking the needle hub (6) in a forward position relative to the carrier body (2), and second release means (15A) unlocking the needle hub (6) from the forward position."

Claims 2 to 12 are dependent claims.

VI. The arguments of the appellant which are relevant for the present decision may be summarised as follows:

*Sufficiency of disclosure*

The patent disclosed some alternatives of an inserter for inserting a medical device, particularly in paragraphs [0034] to [0036]. However, the invention was not sufficiently disclosed to enable the skilled person to devise the inserter for inserting any transcutaneous medical device. A broad claim for an "inserter for a medical device" contradicted the acknowledged and well-established fundamental principle that the scope of protection should correspond to the contribution to the art. It was completely obscure how the medical device should be connected/coupled to any elements of the claimed inserter, how it should interact with the elements of the inserter, or how it should move during insertion. In particular, in paragraph [0035] in its reference to Figure 6, the medical device was disclosed as comprising a mounting pad 20 having an adhesive surface, so the skilled person could not devise the stationary part 10 to be capable of resting against the patient's skin as well, as required by claim 1.

*Novelty*

The embodiment of Figures 9A to 9C of D1 anticipated the subject-matter claimed. Moreover, page 16, line 12 to 19 related this embodiment to further features disclosed in Figures 4 to 6 and 7. In particular, in Figure 7, a leaf spring member 155 biasing needle unit 150 upwardly was disclosed (page 13, lines 14 to

17). Hence, a leaf spring member as shown in Figure 7 held the carrier body 353 of Figures 9A to 9C in a retracted position. The leaf spring therefore constituted "first locking means" as claimed. Once the inserter spring 337 was activated, the carrier body was displaced from the retracted position and hence unlocked. Therefore, also the first release means as defined in claim 1 were known from D1.

*Inventive step*

The claimed first locking means had the technical effect of firmly locking the carrier body 353 in D1 in the retracted position. Consequently, the objective technical problem to be solved was to better fix the carrier body in position. It was desirable to keep the force-locking effect of the second elastic element 368 rather low since this biasing force had to be overcome by the first elastic element 337 for moving the transcutaneous device from its retracted to its forward position. Such a low force, however, would not prevent undesired movements of the transcutaneous needle unit 350, for example, during transportation. It was therefore straight forward for the skilled person to provide first locking means as claimed. For solving exactly the same type of problem, such locking means had been known to the skilled person in the form of a catch-release mechanism for - at least - a hundred years. Even Figures 9A to 9C of D1 explicitly showed such an arrangement in the form of second locking means 357, 367 for releasably locking the needle hub 363 in a forward position relative to the carrier body. The skilled person would directly contemplate implementing a similar arrangement as first locking means as claimed, for example, by attaching a releasable latch onto the vertical side wall of ramp member 347 for



releasably holding the underside of carrier body 353. Therefore, the inserter of claim 1 was not based on an inventive step in view of D1.

Moreover, claim 1 was not based on an inventive step over D1 as closest prior art in combination with any of documents D2, D3 and D8. In fact, each of these documents disclosed locking and release members of a carrier body in a retracted position which the skilled person would incorporate in an obvious way into the device known from D1 in order to solve the problem posed.

VII. The arguments of the respondent which are relevant for the present decision are essentially those on which the reasons set out below are based.

### **Reasons for the Decision**

1. The appeal is admissible.
2. *The invention*

The invention relates to an inserter for a medical device, such as an infusion device, comprising, in particular, two elastic elements (inserter spring 11 and retraction spring 12), as shown for example in Figure 2C. The first elastic element (inserter spring 11) has the functions of inserting the penetrating (needle) member (6A) together with the medical device into the patient's skin and of energising the second elastic element (retraction spring 12) for retracting the penetrating member (6A) and leaving the medical

device in the patient's skin (paragraph [0009] of the patent).

3. *Main request*

3.1 *Sufficiency of disclosure*

3.1.1 The invention as defined in claim 1 is concerned with an inserter for a medical device. The patent extensively describes an embodiment of such an inserter and depicts it in Figures 1 to 5. Paragraph [0034] explains, in particular, that the medical device may be placed on or in connection with the penetrating member 6A, for example inside the stationary part 10 of the inserter. Paragraph [0036] further explains that the medical device may comprise a cannula with the penetrating member 6A placed inside.

Article 83 EPC does not require that each and every detail of the construction, movement and connection of the elements of the inserter be described. Moreover, possible discrepancies between technical details of features described and their corresponding definition in the claim do not lead to the conclusion that the skilled person is unable to carry out the claimed invention. For example, although in the example of paragraph [0035] and Figure 6 the medical device is disclosed as comprising a mounting pad 20 with an adhesive surface for application onto the patient's skin, the skilled person using common general knowledge would have no difficulty to devise the stationary part 10 of the inserter so that it rests against the patient's skin as well, as required by claim 1. In fact, it would be straight-forward for the skilled person to devise the stationary part 10 shown in Figures 1A to 1C and described in paragraphs [0021]

to [0025] with a rim surrounding the mounting pad 20 so that the rim rests against the patient's skin.

Hence, the patent discloses at least one example of the claimed inserter for inserting a medical device with sufficient detail to enable the skilled person to carry it out.

3.1.2 Neither does the sufficiency requirement of Article 83 EPC call for the patent to disclose an inserter for any conceivable medical device, as argued by the appellant. Even if hypothetical, non-implementable constructions may be conceived, this does not prevent the skilled person from implementing alternative workable inserters falling under the terms claimed by mere trial and error, without undue burden or having to resort to inventive ingenuity. The appellant did not demonstrate that this would not be possible. An objection of insufficient disclosure presupposes that there are serious doubts substantiated by verifiable facts; mere conjecture is not enough.

3.1.3 The Board therefore concludes that claim 1 of the main request satisfies the requirements of sufficiency of disclosure within the meaning of Article 83 EPC.

### 3.2 *Novelty*

3.2.1 Lack of novelty has been objected to based on the disclosure in D1 of the needle inserter depicted in Figures 9A to 9C and described on page 16, line 12 to page 17, line 7, making particular reference to further aspects disclosed in relation to Figures 4 to 6 (page 16, lines 12 to 14). Figure 9A of D1 is the following:

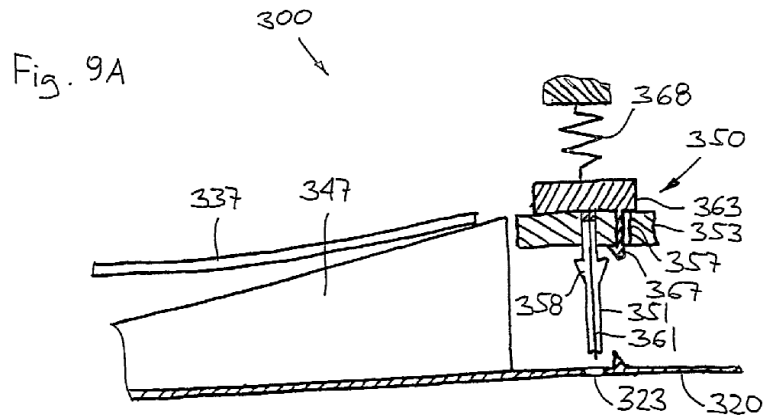

3.2.2 It is common ground between the parties that this embodiment anticipates the following subject-matter, using the terminology of claim 1:

An inserter for a medical device comprising a house (as depicted for example in Figure 4A), two elastic elements (inserter spring 337, spring member 368), where activation of the first elastic element (inserter spring 337, which is analogous to inserter spring 237 of Figures 4C and 4E) causes a penetrating member (insertion needle 361) to be inserted sub- or transcutaneously into the skin of a patient and the second elastic element (368) causes the penetrating member (361) to be retracted from the skin of the patient, where the first elastic element (337) is in an unloaded state before activation, and upon activation the first elastic element energises the second elastic element (368) (page 16, line 31 to page 17, line 3), a stationary part (base plate 320) being stationary in relation to the patient during insertion and resting against the patient's skin, activation means (actuation member 230 in Figure 4A),

a carrier body (353) which carrier body (353) has a forward and a retracted position relative to the stationary part (320),  
a needle hub (363) connected with a penetrating member (361),  
second locking means (mating coupling means 357, 367) locking the needle hub (363) in a forward position relative to the carrier body (353), and  
second release means (coupling release member 348 in Figure 9B) unlocking the needle hub 363 from the forward position (page 16, line 33 to page 17, line 7).

- 3.2.3 The Board agrees with the respondent in that the inserter of D1 lacks "first locking means locking the carrier body in a retracted position" and "first release means unlocking the carrier body from a retracted position".

The appellant was of the opinion that page 16, lines 14 to 19 of D1 should be understood as disclosing that the embodiment of Figures 9A to 9C could be provided with features taken from the device depicted in Figure 7. In the latter, a leaf spring member 155 biases a needle unit 150 upwardly (page 13, lines 14 to 17). The appellant considered, thus, that a leaf spring member as in Figure 7 was also present in the embodiment of Figures 9A to 9C holding the carrier body 353 in a retracted position, thereby constituting "first locking means" as claimed.

In the Board's view, however, the needle unit 350 of Figures 9A to 9C is not directly and unambiguously disclosed as comprising the leaf spring member 155 of needle unit 150 of Figure 7. The disclosure of page 16, lines 14 to 19 is rather imprecise when it states that Figures 9A to 9C provide "a transcutaneous device

unit 350 of the type shown in [the needle unit of] fig. 7". This statement seems to merely suggest some sort of qualitative similarity between the needle unit shown in Figures 9A to 9C on the one hand, and the needle unit shown in Figure 7 on the other. In fact, while the needle unit 350 of Figures 9A to 9C comprises spring member 368 to bias the flexible arm 353 upwards (page 16, lines 26 to 28), there is no disclosure of the flexible arm being biased upwards by a *further* spring member, such as the leaf spring member 155 of the needle unit of Figure 7.

The Board considers, therefore, that the embodiment of Figures 9A to 9C lacks means locking the carrier body 353 in a retracted position, i.e. in D1 there are no "first locking means" as claimed. As a consequence, there are no release means either for unlocking the carrier body 353 from the retracted position, so that the "first release means" as claimed are missing from D1 too.

3.2.4 Hence, the subject-matter of claim 1 of the main request is novel within the meaning of Article 54 EPC.

### 3.3 *Inventive step*

3.3.1 It was not disputed that document D1 constitutes the closest prior art. As indicated above, the inserter of claim 1 differs from that of D1 by "first locking means locking the carrier body in a retracted position" and "first release means unlocking the carrier body from a retracted position" of claim 1.

3.3.2 These differentiating features have the technical effect of releasably locking the carrier body in a retracted position. In D1, the carrier body 353 is held

in the retracted position by the second elastic element (spring member 368). Its biasing force has to be low enough to be overcome by that of the first elastic element 337 for inserting the penetrating member (insertion needle 361) into the skin of a patient. Therefore, the objective technical problem to be solved can be seen to better fix the carrier body of D1 in its retracted position.

3.3.3 It is undeniable that locking means in the form of a catch-release mechanism have long been known to the skilled person. Moreover, Figures 9A to 9C explicitly show such an arrangement for releasably locking the needle hub 363 in a forward position relative to the carrier body 353 in the form of second locking means (mating coupling means 357, 367). Nevertheless, there is no reason why the skilled person would contemplate such a locking and release mechanism for locking and releasing the carrier body 353 when the needle is retracted, particularly since the spring member 368 already provides a firm hold of the carrier body prior to needle insertion. Moreover, it is not at all straightforward how such an additional locking and release mechanism would be implemented into the specific construction of Figure 9A. Attaching a releasable latch onto the vertical wall of the ramp member 347 for releasably holding the underside of carrier body 353, as suggested by the appellant during the oral proceedings, appears to be technically awkward, and therefore anything but obvious.

3.3.4 The Board finds, therefore, that the disclosure of D1 would not prompt the skilled person to incorporate the locking and release means as claimed into the inserter of Figures 9A to 9C D1 in an obvious way.

3.3.5 The appellant pointed, moreover, to locking and release means known from the inserters disclosed in documents D2, D3 and D8.

Document D2 (which is cited in paragraph [0002] of the patent) discloses a device for insertion of a cannula or an infusion device into the skin of a patient and for retraction of the insertion needle. In the embodiment depicted in Figure 102, barbs 1956 are unlocked and released from the protruding member 1958 when the cap 1952 comprising shoulders 1954 is pressed downwards.

In document D3, Figures 16 and 20, an inserter for a sensor is depicted which comprises first locking and release means in the form of interlocking stops or fingers 412 that are unlocked and released from the stops 386 when the arms 378 are pressed downwards (paragraphs [0104] and [0107]).

Finally, document D8 relates to an inserter for an infusion set which uses two protruding members for locking carrier body 2 in position prior to activation of the inserter. The carrier body 2 is then released by deformation of the housing which results in the protruding members releasing their grip on the carrier body 2 (paragraph [0044]).

The locking and release means disclosed in each of the very specific inserter constructions disclosed in D2, D3 and D8 could not be implemented in the entirely different inserter construction of D1 in any straight-forward way. Most strikingly, D2, D3 and D8 concern inserters which are axially activated, causing an insertion movement in that same axial direction; instead, in D1 (Figure 9A), activation of the inserter



spring 337 is performed in a lateral direction (as shown in Figures 4A and 4E), that is, in a horizontal direction in Figure 9A, causing an insertion movement of the needle 361 in a perpendicular direction.

Hence, the skilled person starting from D1 and trying to solve the objective technical problem stated under point 3.3.2 above, would not readily contemplate including the solutions of any of D2, D3 and D8 in the device of D1 as this would complicate the construction of D1 and render it unworkable. Even if the skilled person had any reason to incorporate in D1 any of the locking and release means known from D2, D3 and D8, he would be left with the unsolved problem of how to make such means work in combination with the already existing features in D1.

- 3.3.6 Therefore, the combination of D1 with any one of documents D2, D3 and D8 would not have readily led the skilled person to an inserter as claimed.
- 3.3.7 As a consequence, the subject-matter of claim 1 of the main request satisfies the requirements of inventive step in accordance with Article 56 EPC. This applies, a fortiori, to the preferred embodiments of claims 2 to 12.
4. The objections raised do not prejudice the maintenance of the patent on the basis of the main request.

## Order

### For these reasons it is decided that:

1. The decision under appeal is set aside.
2. The case is remitted to the department of first instance with the order to maintain the patent on the basis of:
  - claims 1 to 12 of the main request filed during the oral proceedings;
  - description:  
pages 1, 2, 4, 6 and 7 of the patent as granted and pages 3 and 5 filed during oral proceedings on 19 June 2013 (18:02); and
  - drawing sheets 1 to 11 of the patent as granted.

The Registrar:

The Chairman:



D. Hampe

E. Dufrasne

Decision electronically authenticated