

Internal distribution code:

- (A) [-] Publication in OJ
(B) [-] To Chairmen and Members
(C) [-] To Chairmen
(D) [X] No distribution

**Datasheet for the decision
of 14 February 2019**

Case Number: T 0406/14 - 3.2.02

Application Number: 10702370.7

Publication Number: 2398532

IPC: A61M5/142, A61M39/28

Language of the proceedings: EN

Title of invention:

INFUSION PUMP CASSETTE WITH ANTI-FREE-FLOW VALVE MECHANISM

Applicant:

Nestec S.A.

Headword:

Relevant legal provisions:

EPC Art. 84
RPBA Art. 15(1), 15(3)
EPC R. 115(2)

Keyword:

Claims - clarity (no)

Decisions cited:

Catchword:



Beschwerdekammern
Boards of Appeal
Chambres de recours

Boards of Appeal of the
European Patent Office
Richard-Reitzner-Allee 8
85540 Haar
GERMANY
Tel. +49 (0)89 2399-0
Fax +49 (0)89 2399-4465

Case Number: T 0406/14 - 3.2.02

D E C I S I O N
of Technical Board of Appeal 3.2.02
of 14 February 2019

Appellant: Nestec S.A.
(Applicant) Avenue Nestlé 55
1800 Vevey (CH)

Representative: Rupp, Christian
Mitscherlich PartmbB
Patent- und Rechtsanwälte
Sonnenstraße 33
80331 München (DE)

Decision under appeal: **Decision of the Examining Division of the
European Patent Office posted on 19 September
2013 refusing European patent application No.
10702370.7 pursuant to Article 97(2) EPC.**

Composition of the Board:

Chairman E. Dufrasne
Members: P. L. P. Weber
S. Böttcher

Summary of Facts and Submissions

- I. The appeal of the applicant is against the decision of the Examining Division posted on 19 September 2013 to refuse the application.

Notice of appeal was filed on 26 November 2013 and the appeal fee was paid on the same day. The statement setting out the ground of appeal was filed on 16 January 2014.

- II. The appellant requested in writing that the decision under appeal be set aside and that a patent be granted on the basis of one of the main request and auxiliary requests I to V filed by letter dated 16 January 2014.

- III. By letter dated 28 November 2018 the Board summoned the appellant to oral proceedings to be held on 14 February 2019. In a communication according to Article 15(1) RPBA the Board informed the appellant of its provisional opinion. In particular, the following was stated:

"3. In all requests it is not clear in claim 1 that the tab member is meant for engagement by the activation mechanism of the pump, which seems to be an essential feature of the invention. Hence, the requirements of Article 84 EPC are not met.

The fact that the activation mechanism should be designed to move independently of both the cassette and the pumping mechanism when moving the tab member, as argued by the appellant, is also not apparent in the wording of the claims.

Furthermore it is not clear in the claims relating to the fluid delivery system how the pumping mechanism can provide movement of the fluid when the cassette is engaged with the pump if the tab member is not in a fluid delivery position.”

IV. By letter dated 10 December 2018 the applicant informed the Board that it would not attend the oral proceedings and requested a decision according to the state of the file. No substantive reply was submitted.

V. Oral proceedings were held on 14 February 2019.

Duly summoned by communication dated 28 November 2018, the appellant did not attend the oral proceedings, as announced by letter dated 10 December 2018, such that the proceedings were continued in its absence in accordance with Rule 115(2) EPC and Article 15(3) RPBA.

VI. The relevant claims read as follow:

(a) Claims 1 and 6 of the main request read as follows:

“1. A cassette for engagement with an infusion pump (2) for delivery of a fluid to a subject comprising: a housing (5) having first and second ends (10,30) for holding a flexible tubing (75) of the cassette (1) through which the fluid is directed, wherein the tubing (75) is configured for engaging a pumping mechanism (210) of an infusion pump (2) that provides movement of fluid through the tubing (75); an anti-flow valve mechanism (100) comprising a moveable member (103) and a force applying member (110), wherein the anti-flow valve mechanism (100) is associated with the tubing (75) and is biased against

the tubing (75) in a fluid non-delivery position to prevent flow therethrough [sic]; and a tab member (107) operatively associated with the cassette housing (5) and the anti-flow valve mechanism (100) and arranged movable between the fluid non-delivery position and a fluid-delivery position in which a bias of the force-applying member (110) is overcome to allow flow of fluid through the tubing (75); wherein the housing (5) is configured and dimensioned for engagement with the infusion pump (2).

6. A fluid delivery system comprising:

- a) the cassette (1) as claimed in any one of claim [sic] 1-5; and
- b) an infusion pump (2),

wherein the pump (2) includes a pump housing (201) having an opening (230) configured and dimensioned to receive the cassette (1); and an activation mechanism (220) for engaging the tab member (107) and thereby causing the tab member to move between the fluid non-delivery position and the fluid delivery position to allow fluid flow through the tubing (75), and a pumping mechanism (210) designed to engage the flexible tubing (75) to provide movement of fluid through the tubing when the cassette (1) is engaged with the pump (2), wherein the activation mechanism (220) is designed to move independently of both the cassette (1) and the pumping mechanism (210) when moving the tab member (107)."

(b) Claims 1 and 6 according to auxiliary request I read as follows:

"1. A cassette for engagement with an infusion pump (2) for delivery of a fluid to a subject comprising:

a housing (5) comprising four outside walls (10,20,30,40) and two faces (50,60), wherein a first and a third outside wall (10,30) are arranged opposite to each other and each comprise a flat wall with an opening (12,32) through which an inlet or outlet tubing support (15,35) is fitted, and define first and second ends (10,30) for holding a flexible tubing (75) of the cassette (1) through which the fluid is directed, wherein the tubing (75) is configured for engaging a pumping mechanism (210) of an infusion pump (2) that provides movement of fluid through the tubing (75); an anti-flow valve mechanism (100) situated in the housing (5) and comprising a moveable member (103) and a force-applying member (110), and being biased against the tubing (75) in a fluid non-delivery position to prevent flow therethrough; wherein the moveable member (103) comprises a pinch head (105) and a tab member (107), which is operatively associated with the cassette housing (5) and the anti-flow valve mechanism (100) and arranged movable between the fluid non-delivery position and a fluid-delivery position in which a bias of the force-applying member (110) is overcome to allow flow of fluid through the tubing (75); wherein the tab member (107) extends perpendicular to the orientation of the moveable member and the force-applying member (110) through an opening (57) in a first face (50) of the housing (5), and wherein during or after engagement with the infusion pump (2), the tab member (107) assumes the fluid delivery position to allow flow of fluid through the tubing, while before or as the cassette is removed from the pump (2), the tab member (107) assumes the fluid non-delivery position to prevent flow of fluid through the tubing.

6. A fluid delivery system comprising:

a) the cassette (1) as claimed in any one of claim [sic] 1-5; and
b) an infusion pump (2),
wherein the pump (2) includes a pump housing (205) having an opening (230) configured and dimensioned to receive the cassette (1); and an activation mechanism (220) for engaging the tab member (107) and thereby causing the tab member to move between the fluid non-delivery position and the fluid delivery position to allow fluid flow through the tubing (75), and a pumping mechanism (210) designed to engage the flexible tubing (75) to provide movement of fluid through the tubing when the cassette (1) is engaged with the pump (2)."

(c) Claims 1 and 6 according to auxiliary request II read as follows:

"1. A cassette for engagement with an infusion pump (2) for delivery of a fluid to a subject comprising:
a housing (5) comprising four outside walls (10,20,30,40) and two faces (50,60), wherein a first and a third outside wall (10,30) are arranged opposite to each other and each comprise a flat wall with an opening (12,32) through which an inlet or outlet tubing support (15,35) is fitted, and define first and second ends (10,30) for holding a flexible tubing (75) of the cassette (1) through which the fluid is directed, wherein the tubing (75) is configured for engaging a pumping mechanism (210) of an infusion pump (2) that provides movement of fluid through the tubing (75); an anti-flow valve mechanism (100) situated in the housing (5) and comprising a moveable member (103) and a force-applying member (110), and being biased against the tubing (75) in a fluid non-delivery position to prevent flow therethrough;

wherein the moveable member (103) comprises a pinch head (105) and a tab member (107), which is operatively associated with the cassette housing (5) and the anti-flow valve mechanism (100) and arranged movable between the fluid non-delivery position and a fluid-delivery position in which a bias of the force-applying member (110) is overcome to allow flow of fluid through the tubing (75);

wherein the force-applying member (110) is a compression spring;

wherein the tab member (107) extends perpendicular to the orientation of the moveable member and the axis of the force-applying member (110) through an opening (57) in a first face (50) of the two faces (50,60) of the housing (5), and wherein during or after engagement with the infusion pump (2), the tab member (107) assumes the fluid delivery position to allow flow of fluid through the tubing, while before or as the cassette is removed from the pump (2), the tab member (107) assumes the fluid non delivery position to prevent flow of fluid through the tubing.

6. A fluid delivery system comprising:

a) the cassette (1) as claimed in any one of claim [sic] 1-5; and

b) an infusion pump (2),

wherein the pump (2) includes a pump housing (205) having an opening (230) configured and dimensioned to receive the cassette (1); and an activation mechanism (220) for engaging the tab member (107) and thereby causing the tab member to move between the fluid non-delivery position and the fluid delivery position to allow fluid flow through the tubing (75), and a pumping mechanism (210) designed to engage the flexible tubing (75) to provide movement of fluid through the tubing when the cassette (1) is engaged with the pump (2)."

(d) Claims 1 and 6 according to auxiliary request III read as follows:

"1. A cassette for engagement with an infusion pump (2) for delivery of a fluid to a subject comprising: a housing (5) comprising four outside walls (10,20,30,40) and two faces (50,60), wherein a first and a third outside wall (10,30) are arranged opposite to each other and each comprise a flat wall with an opening (12,32) through which an inlet or outlet tubing support (15,35) is fitted, and define first and second ends (10,30) for holding a flexible tubing (75) of the cassette (1) through which the fluid is directed, wherein the tubing (75) is configured for engaging a pumping mechanism (210) of an infusion pump (2) that provides movement of fluid through the tubing (75); an anti-flow valve mechanism (100) situated in the housing (5) and comprising a moveable member (103) and a force-applying member (110), and being biased against the tubing (75) in a fluid non-delivery position to prevent flow therethrough; wherein the moveable member (103) comprises a pinch head (105) and a tab member (107), which is operatively associated with the cassette housing (5) and the anti-flow valve mechanism (100) and arranged movable between the fluid non-delivery position and a fluid-delivery position in which a bias of the force-applying member (110) is overcome to allow flow of fluid through the tubing (75); wherein the force-applying member (110) is a compression spring; wherein the tab member (107) extends perpendicular to the orientation of the moveable member and the axis of the force-applying member (110) through an opening (57) in a first face (50) of the two faces (50,60) of the housing (5) both

in the fluid non-delivery position and the fluid-delivery position, and wherein during or after engagement with the infusion pump (2), the tab member (107) assumes the fluid delivery position to allow flow of fluid through the tubing, while before or as the cassette is removed from the pump (2), the tab member (107) assumes the fluid non-delivery position to prevent flow of fluid through the tubing.

6. A fluid delivery system comprising:

a) the cassette (1) as claimed in any one of claim [sic] 1-5; and
b) an infusion pump (2),
wherein the pump (2) includes a pump housing (205) having an opening (230) configured and dimensioned to receive the cassette (1); and an activation mechanism (220) for engaging the tab member (107) and thereby causing the tab member to move between the fluid non-delivery position and the fluid delivery position to allow fluid flow through the tubing (75), and a pumping mechanism (210) designed to engage the flexible tubing (75) to provide movement of fluid through the tubing when the cassette (1) is engaged with the pump (2)."

(e) Claims 1 and 5 according to auxiliary request IV read as follows:

"1. A cassette for engagement with an infusion pump (2) for delivery of a fluid to a subject comprising:
a housing (5) comprising four outside walls (10,20,30,40) and two faces (50,60), wherein a first and a third outside wall (10,30) are arranged opposite to each other and each comprise a flat wall with an opening (12,32) through which an inlet or outlet tubing support (15,35) is fitted, and define first and second

ends (10,30) for holding a flexible tubing (75) of the cassette (1) through which the fluid is directed, wherein the tubing (75) is configured for engaging a pumping mechanism (210) of an infusion pump (2) that provides movement of fluid through the tubing (75); an anti-flow valve mechanism (100) situated in the housing (5) and comprising a moveable member (103) and a force-applying member (110), and being biased against the tubing (75) in a fluid non-delivery position to prevent flow therethrough; wherein the moveable member (103) comprises a pinch head (105) and a tab member (107), which is operatively associated with the cassette housing (5) and the anti-flow valve mechanism (100) and arranged movable between the fluid non-delivery position and a fluid-delivery position in which a bias of the force-applying member (110) is overcome to allow flow of fluid through the tubing (75); wherein the tab member (107) extends perpendicular to the orientation of the moveable member and the force-applying member (110) through an opening (57) in a first face (50) of the housing (5), and wherein during or after engagement with the infusion pump (2), the tab member (107) assumes the fluid delivery position to allow flow of fluid through the tubing, while before or as the cassette is removed from the pump (2), the tab member (107) assumes the fluid non-delivery position to prevent flow of fluid through the tubing; and wherein the housing (75) has an essentially rectangular shape and is configured and dimensioned to fit within an opening in the infusion pump (2), and wherein the length of tubing (75) is held between the ends of the cassette (1) in a straight line and in front of a fixed, rigid curved wall (25) of the housing (5) such that when engaged with the pumping mechanism (210) of the pump (2), the length of tubing (75) is

accurately positioned in contact with and between the curved wall (25) and the pumping mechanism (210).

5. A fluid delivery system comprising:

a) the cassette (1) as claimed in any one of claim [sic] 1-4; and

b) an infusion pump (2),

wherein the pump (2) includes a pump housing (205) having an opening (230) configured and dimensioned to receive the cassette (1); and an activation mechanism (220) for engaging the tab member (107) and thereby causing the tab member to move between the fluid non-delivery position and the fluid delivery position to allow fluid flow through the tubing (75), and a pumping mechanism (210) designed to engage the flexible tubing (75) to provide movement of fluid through the tubing when the cassette (1) is engaged with the pump (2)."

(f) Claims 1 and 5 according to auxiliary request V read as follows:

"1. A cassette for engagement with an infusion pump (2) for delivery of a fluid to a subject comprising:
a housing (5) comprising four outside walls (10,20,30,40) and two faces (50,60), wherein a first and a third outside wall (10,30) are arranged opposite to each other and each comprise a flat wall with an opening (12,32) through which an inlet or outlet tubing support (15,35) is fitted, and define first and second ends (10,30) for holding a flexible tubing (75) of the cassette (1) through which the fluid is directed, wherein the tubing (75) is configured for engaging a pumping mechanism (210) of an infusion pump (2) that provides movement of fluid through the tubing (75); an anti-flow valve mechanism (100) situated in the housing (5) and comprising a moveable member (103) and

a force-applying member (110), and being biased against the tubing (75) in a fluid non-delivery position to prevent flow therethrough;

wherein the moveable member (103) comprises a pinch head (105) and a tab member (107), which is operatively associated with the cassette housing (5) and the anti-flow valve mechanism (100) and arranged movable between the fluid non-delivery position and a fluid-delivery position in which a bias of the force-applying member (110) is overcome to allow flow of fluid through the tubing (75);

wherein the force-applying member (110) is a compression spring; wherein the tab member (107) extends perpendicular to the orientation of the moveable member and the axis of the force-applying member (110) through an opening (57) in a first face (50) of the two faces (50,60) of the housing (5), and wherein during or after engagement with the infusion pump (2), the tab member (107) assumes the fluid delivery position to allow flow of fluid through the tubing, while before or as the cassette is removed from the pump (2), the tab member (107) assumes the fluid non delivery position to prevent flow of fluid through the tubing;

and wherein the housing (75) has an essentially rectangular shape and is configured and dimensioned to fit within an opening in the infusion pump (2), and wherein the length of tubing (75) is held between the ends of the cassette (1) in a straight line and in front of a fixed, rigid curved wall (25) of the housing (5) such that when engaged with the pumping mechanism (210) of the pump (2), the length of tubing (75) is accurately positioned in contact with and between the curved wall (25) and the pumping mechanism (210).

5. A fluid delivery system comprising:

a) the cassette (1) as claimed in any one of claim [sic] 1-4; and
b) an infusion pump (2),
wherein the pump (2) includes a pump housing (205) having an opening (230) configured and dimensioned to receive the cassette (1); and an activation mechanism (220) for engaging the tab member (107) and thereby causing the tab member to move between the fluid non-delivery position and the fluid delivery position to allow fluid flow through the tubing (75), and a pumping mechanism (210) designed to engage the flexible tubing (75) to provide movement of fluid through the tubing when the cassette (1) is engaged with the pump (2)."

Reasons for the Decision

1. The appeal is admissible.
2. In its communication pursuant to Article 15(1) RPBA the Board raised a clarity objection pursuant to Article 84 EPC against all the requests on file, i.e. because an essential feature was not mentioned in claim 1.
3. The invention is about an infusion pump cassette with an anti-free-flow valve mechanism and a fluid delivery system comprising such a cassette and an infusion pump. Infusion pumps are widely used to administer fluids to patients in a regulated manner. The fluid travels to the patient through a tubing attached on one side to a fluid reservoir and on the other side to the infusion needle, the flow rate being dictated and regulated by the infusion pump (mostly a peristaltic pump). To avoid possible fluid flow (by gravity) out of the tubing when the cassette containing the tubing is removed from the infusion pump, an anti-flow valve placed inside the cassette is biased against the tubing in a fluid non-

delivery position (e.g. paragraphs [0001], [0003] and [0008] of the application). In that way, when the cassette is not in the infusion pump, the free flow of fluid out of the tubing is avoided.

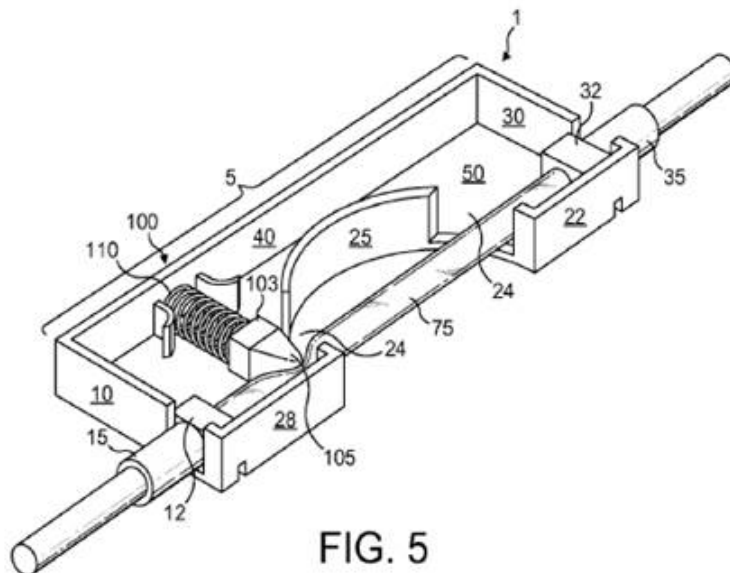

A tab member (107) is operatively associated with the cassette housing and the anti-flow valve mechanism, and this tab member is arranged movable between the said fluid non-delivery position and a fluid-delivery position against the biasing force applied to the anti-flow valve member. When the cassette is in the infusion pump or already during insertion of the cassette into the pump, the tab member is engaged and moved by an activation mechanism present in the infusion pump (e.g. [00012]) in order to put the anti-flow valve mechanism into a fluid delivery position.

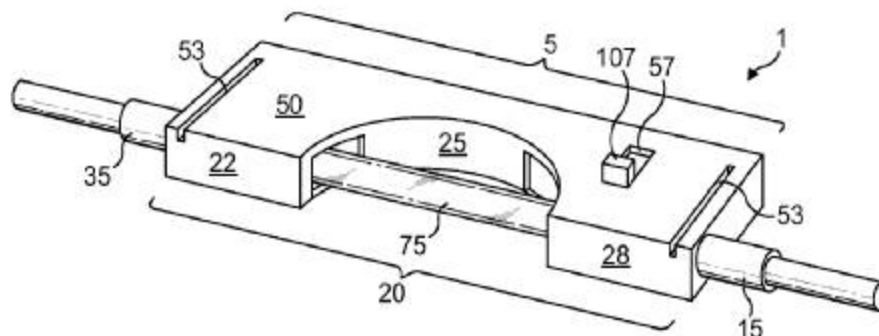

FIG. 1

It appears therefore that the cassette and the infusion pump must be dedicated to each other as is, for instance, expressed at the end of paragraph [0008] (*"The housing [of the cassette] is configured and dimensioned for engagement with a dedicated infusion pump,..."*), and that the activation mechanism must be able to act on the tab member (107) to put or not the anti-flow valve mechanism into the fluid delivery position to allow or not the fluid delivery as explained in paragraph [00012] (*"...and an activation mechanism for engaging the member and thereby causing the member to move between the fluid non-delivery position and the fluid delivery position to allow fluid flow through the tubing,..."*).

This appears to be an essential feature of the invention necessary in order to obtain the desired effect. Indeed, a cassette having a tab member which were not movable by the activation mechanism of the infusion pump would not be able to be put in the fluid delivery position by that activation mechanism.

However, in none of claim 1 of any of the requests on file it is mentioned that the tab member (107) present in the cassette must be engageable by the activation mechanism (220) present in the infusion pump to thereby

cause the tab member to move between the fluid non-delivery position and the fluid delivery position. Such a feature would have established the essential link between the claimed cassette and the infusion pump allowing the desired effect to be obtained, namely to be able to move or not the movable member (103) into the fluid delivery position against the biasing force of the force applying member (110).

4. The only passage in the statement setting out the grounds of appeal indirectly referring to the above is on page 3, fifth paragraph, under the heading "The invention as claimed":

"As the tab member operatively associated with the housing of the cassette and the anti-flow valve mechanism, it is designed to enable a direct interaction of the anti-flow valve mechanism of the cassette with a dedicated activation means provided at the infusion pump. Thereby, upon engagement of the cassette with the pump, such as an insertion of the cassette into an opening of the pump or by attachment of the cassette to a position on the exterior of a housing of the pump, the anti-flow valve mechanism may be engaged without any further operation necessary, such as e.g. a closure of a lid member of the pump. (emphasis added)"

In this paragraph the appellant itself acknowledges the importance of the link mentioned above, but this link is not present in the claims.

As mentioned under point IV above, no comment on the raised clarity objection was received from the appellant after the summons.

5. Therefore, the claims 1 of all requests on file infringe Article 84 EPC.

Order

For these reasons it is decided that:

The appeal is dismissed.

The Registrar:

The Chairman:



D. Hampe

E. Dufrasne

Decision electronically authenticated