

**Internal distribution code:**

- (A) [ - ] Publication in OJ  
(B) [ - ] To Chairmen and Members  
(C) [ - ] To Chairmen  
(D) [ X ] No distribution

**Datasheet for the decision  
of 4 March 2015**

**Case Number:** T 0467/12 - 3.3.05

**Application Number:** 03775313.4

**Publication Number:** 1575695

**IPC:** B01F3/08

**Language of the proceedings:** EN

**Title of invention:**

PROCESS FOR MANUFACTURE OF PERSONAL CARE PRODUCTS UTILIZING A  
CONCENTRATE WATER PHASE

**Patent Proprietor:**

Unilever PLC  
Unilever N.V.

**Opponents:**

The Procter & Gamble Company  
BEIERSDORF AG

**Headword:**

Process/UNILEVER

**Relevant legal provisions:**

EPC Art. 56

**Keyword:**

Inventive step - all requests (no) -  
effect not credible within the whole scope of claim -  
reformulation of the problem into an alternative -  
obviousness of the solution

**Decisions cited:**

**Catchword:**



**Beschwerdekammern  
Boards of Appeal  
Chambres de recours**

European Patent Office  
D-80298 MUNICH  
GERMANY  
Tel. +49 (0) 89 2399-0  
Fax +49 (0) 89 2399-4465

Case Number: T 0467/12 - 3.3.05

**D E C I S I O N  
of Technical Board of Appeal 3.3.05  
of 4 March 2015**

**Appellant III:** Unilever PLC  
(Patent Proprietor 1) Unilever House  
Blackfriars  
London  
Greater London EC4P 4BQ (GB)

**Appellant III:** Unilever N.V.  
(Patent Proprietor 2) Weena 455  
3013 AL Rotterdam (NL)

**Representative:** Potter Clarkson LLP  
The Belgrave Centre  
Talbot Street  
Nottingham, NG1 5GG (GB)

**Appellant I:** The Procter & Gamble Company  
(Opponent 1) One Procter & Gamble Plaza  
Cincinnati, OHIO 45202 (US)

**Representative:** Simpson, Tobias Rutger  
Mathys & Squire LLP  
The Shard  
32 London Bridge Street  
London SE1 9SG (GB)

**Appellant II:** BEIERSDORF AG  
(Opponent 2) Unnastrasse 48  
D-20245 HAMBURG (DE)

**Representative:** Muth, Heinz-Peter  
Uexküll & Stolberg  
Patentanwälte  
Beselerstrasse 4  
22607 Hamburg (DE)

**Decision under appeal:** **Interlocutory decision of the Opposition  
Division of the European Patent Office posted on**

9 January 2012 maintaining the European Patent  
No. 1575695 in amended form.

**Composition of the Board:**

**Chairman** G. Raths  
**Members:** J.-M. Schwaller  
O. Loizou

## Summary of Facts and Submissions

I. The present appeals lie from the interlocutory decision of the opposition division maintaining European patent No. 1 241 138 on the basis of the first auxiliary request filed during the oral proceedings of 28 November 2011, independent claim 1 of which reads as follows:

*"1. A process for manufacture of personal care compositions comprising:*

*(i) feeding a first water phase comprising more than 15% by weight of the first water phase of ingredients other than water and having a viscosity from 50 to 30,000 cps into a blending tube;*

*(ii) feeding a second phase into the blending tube;*

*(iii) feeding a third phase comprising no more than 10% by weight of the third phase of ingredients other than water and having a viscosity of less than 30 cps into the blending tube, the third phase being at least 15% of the composition;*

*(iv) mixing together all three of the phases, each of the phases being pumped into the blending tube as a liquid stream at a pressure from 10 to 5,000 psi and at a flow rate of 2.274 to 2,270 kg (5 to 5,000 pounds) per minute; and*

*(v) recovering a resultant mixture as a personal care composition, **wherein mixing of the phases is by sonic agitation.**"*

Claim 1 as granted reads as follows:

*"1. A process for manufacture of personal care compositions comprising:*

*(i) feeding a first water phase comprising more than 15% by weight of the first water phase of ingredients*

*other than water and having a viscosity from 50 to 30,000 cps into a blending tube;*

*(ii) feeding a second phase into the blending tube;*

*(iii) feeding a third phase comprising no more than 10% by weight of the third phase of ingredients other than water and having a viscosity of less than 30 cps into the blending tube, the third phase being at least 15% of the composition;*

*(iv) mixing together all three of the phases, each of the phases being pumped into the blending tube as a liquid stream at a pressure from 10 to 5,000 psi and at a flow rate of 2.274 to 2,270 kg (5 to 5,000 pounds) per minute; and*

*(v) recovering a resultant mixture as a personal care composition."*

II. The following documents cited in the opposition proceedings are relevant for the present decision:

D5: US 5 006 349

D6: US 5 837 272

D10: Drug & Cosmetic Catalog 1983, one page

D15: WO 03/082220 A2

D18: Declaration of Dr Christian Freese dated  
24 October 2011

III. The contested decision can be summarised as follows:

The patent as granted fulfilled the requirements of Article 83 EPC.

The subject-matter of claim 1 as granted lacked novelty in the light of example 2 and Figure 1 of document D15.

The subject-matter of the claims of the first auxiliary request involved an inventive step because, starting from document D6 as the closest state of the art, even if the problem to be solved was to be reformulated into an alternative process, the solution proposed - namely that the mixing of the three phases takes place by sonic agitation - was not suggested by the available prior art documents.

IV. With its grounds of appeal dated 10 May 2012, appellant II/opponent II argued that the subject-matter of claim 1 as maintained by the opposition division lacked inventive step over, in particular, document D6 taken in combination with document D10.

V. With its grounds of appeal dated 16 May 2012, appellant I/opponent I argued in particular that claim 1 as maintained lacked inventive step over document D6 taken in combination with, in particular, the teaching of document D5.

VI. With its grounds of appeal dated 11 May 2012, appellant III/the proprietor contested the conclusions of the opposition division regarding novelty of the claims as granted. Further, it resubmitted the auxiliary requests 2 to 10 already filed during the opposition proceedings.

Claim 1 of auxiliary request 1 is claim 1 of the set of claims maintained by the opposition division (see I).

VII. By letter of 30 December 2014, appellant III filed nine sets of claims as new auxiliary requests 2 to 10.

Claim 1 of auxiliary request 2 reads as follows:

"1. A process for manufacture of personal care compositions comprising:

(i) feeding a first water phase comprising more than 15% by weight of the first water phase of ingredients other than water and having a viscosity from 50 to 30,000 cps into a blending tube;

(ii) feeding a second phase into the blending tube;

(iii) feeding a third phase comprising no more than 10% by weight of the third phase of ingredients other than water and having a viscosity of less than 30 cps into the blending tube, the third phase being at least 15% of the composition;

(iv) mixing together all three of the phases, each of the phases being **separately** pumped into the blending tube as a liquid stream at a pressure from 10 to 5,000 psi and at a flow rate of 2.274 to 2,270 kg (5 to 5,000 pounds) per minute; and

(v) recovering a resultant mixture as a personal care composition."

Claim 1 of auxiliary request 3 reads as follows:

"1. A process for manufacture of personal care compositions comprising:

(i) feeding a first water phase comprising more than 15% by weight of the first water phase of ingredients other than water and having a viscosity from 50 to 30,000 cps into a blending tube;

(ii) feeding a second phase into the blending tube **which is a Sonolator**;

(iii) feeding a third phase comprising no more than 10% by weight of the third phase of ingredients other than water and having a viscosity of less than 30 cps



*into the blending tube, the third phase being at least 15% of the composition;*

*(iv) mixing together all three of the phases, each of the phases being pumped into the blending tube as a liquid stream at a pressure from 10 to 5,000 psi and at a flow rate of 2.274 to 2,270 kg (5 to 5,000 pounds) per minute; and*

*(v) recovering a resultant mixture as a personal care composition."*

Claim 1 of auxiliary request 4 reads as follows:

*"1. A process for manufacture of personal care compositions comprising:*

*(i) feeding a first water phase comprising more than 15% by weight of the first water phase of ingredients other than water and having a viscosity from 50 to 30,000 cps into a blending tube;*

*(ii) feeding a second phase into the blending tube;*

*(iii) feeding a third phase comprising no more than 10% by weight of the third phase of ingredients other than water and having a viscosity of less than 30 cps into the blending tube, the third phase being at least 15% of the composition;*

*(iv) mixing together all three of the phases, each of the phases being pumped into the blending tube as a liquid stream at a pressure from ~~10~~ **150** to 5,000 psi and at a flow rate of 2.274 to 2,270 kg (5 to 5,000 pounds) per minute; and*

*(v) recovering a resultant mixture as a personal care composition."*

Claim 1 of auxiliary request 5 combines the amendments proposed in the respective claims 1 of auxiliary requests 1 and 2, i.e. the inclusion of the features

**"separately" and "mixing of the phases is by sonic agitation".**

Claim 1 of auxiliary request 6 corresponds to that of auxiliary request 1, to which the following feature has been added at the end: ***","viscosities being measured with a Brookfield RVT Viscometer, Spindle No. RV6 at 20rpm for 1 minute at 25°C."***

Claim 1 of auxiliary requests 7, 8, 9 and 10 corresponds to claim 1 of auxiliary requests 2, 3, 4 and 5, respectively, **as amended in the same manner as claim 1 of of auxiliary request 6.**

VIII. By letter of 26 February 2015, appellant I submitted that claim 1 as granted lacked novelty and inventive step in the light of the disclosure of document D6. Further, it requested that auxiliary requests 2 to 10 not be admitted into the proceedings.

IX. At the oral proceedings, which took place on 4 March 2015, the parties agreed with the board's proposal to discuss first the inventive step of all the requests on file. The discussion focused in this respect on the combination of documents D6 and D5.

X. After closing the debate the chairman summarised the parties' requests as follows:

Appellants I and II request that the decision under appeal be set aside and that the patent be revoked.

Appellant III requests that the decision be set aside and the patent be maintained as granted and that the appeals of appellants I and II be dismissed, or that the patent be maintained in amended form on the basis

of one of the sets of claims according to auxiliary requests 2 to 10 dated 30 December 2014.

## **Reasons for the Decision**

### 1. Preliminary remark

Although certain requests might have been held inadmissible or certain independent claims might not meet the requirements of Articles 123(2) or 84 EPC, the board decided to focus on inventive step issues, because as will be seen below, the same reasoning applies to all the requests on file.

### 2. Main request - Inventive step

By applying the problem-solution approach, the board came to the following conclusions:

2.1 The invention relates to a process for manufacturing liquid personal care compositions.

2.2 As regards the closest state of the art to this invention, the parties agreed that D6 was the most promising starting point to assess inventive step, as this document discloses the preparation of *inter alia* personal care compositions (D6: column 8, lines 47 to 50) with a process which is similar to the one claimed.

Said process, which also makes use of a Sonolator (D6: column 3, lines 62 to 64; reference 24 in Figure 2) as the preferred mixing device, is illustrated in Figure 2, reproduced below, and described in detail at column 9, line 32 to column 10, line 57.

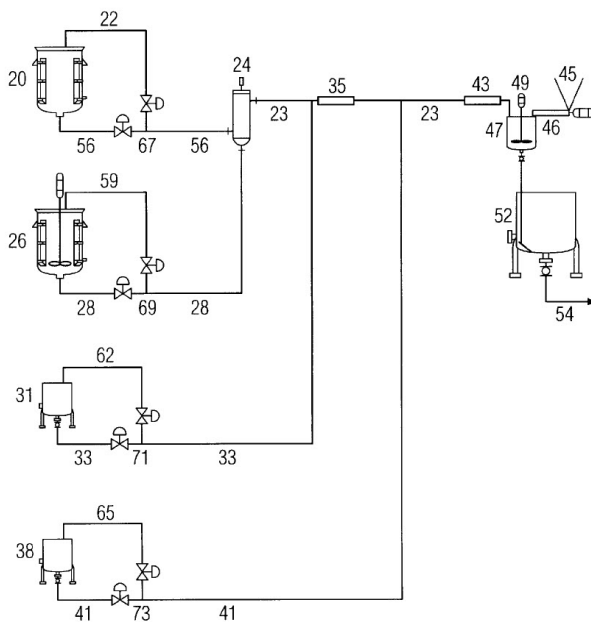

FIG. 2

2.2.1 In Example 1, D6 discloses that an aqueous phase 20 - containing a water soluble chelator, colors, preservatives, an ultraviolet inhibitor and a pH adjusting agent - is fed through line 56 to line 23 at a pressure of 350 psig and a flow rate of 54 pounds/minute. In terms of weight percent of the final composition, this phase corresponds to approximately 54 wt. %.

An "oily" phase 26 containing the organic fragrance, the emulsifier, Triclosan and xanthan gum is fed through line 28 at a rate of 4.6 pounds/minute and a pressure of about 375 psig. About 1.85% of sodium laureth sulfate (30 wt. % active, 70 wt. % water) is also present in the oily phase. The total oily phase as measured by weight percent of the final composition is about 4.6 wt. %.

The oily phase and aqueous phase are combined in the sonolator 24 under a pressure of about 350 psig.

The homogenised aqueous composition is passed through line 23 to the point where an aqueous solution of sodium laureth sulfate 31 is fed into line 23 at a rate of about 35 pounds/minute and a pressure of about 150 psig and mixed with the previous aqueous streams at static mixer 35. The quantity of sodium laureth sulfate and water fed into line 23 is approximately 35 wt. % of the final composition.

The final personal care composition contains the following components (in wt. %):

Sodium Laureth sulfate (2EO)	10.4
Cocoamidopropyl betaine	1.7
Xanthan gum	1.1
Fragrance	0.7
PEG-40 Hydrogenated Castor Oil Trideceth-9	0.07
Encapsulated emollient particles	0.3
Preservatives	0.25
Dipropylene glycol	0.27
Triclosan	0.15
Citric acid anhydrous	0.1
UV protectant	0.05
Colours	Trace
Water	Balance

2.2.2 According to appellant II (see document D18), the phases (i) to (iii) defined in claim 1 as granted have a counterpart as follows in example 1 of D6:

- The first water phase (i) corresponded to the "oily phase" 26 in D6, which comprised 83% of ingredients other than water and had a viscosity

of 21,500 cps; the pumping pressure and flow rate were 375 psig and 2.1 kg/min (i.e. 4.6 pounds/minute), respectively;

- The second phase (ii) corresponded to the aqueous phase 31 in D6; the pumping pressure and the flow rate were 150 psig and 15.6 kg/min, respectively;
- The third phase (iii) corresponded to the aqueous phase 20 which comprised 0.74% of ingredients other than water and had a viscosity of 5 cps; the pumping pressure and the flow rate were 350 psig and 24.5 kg/min.

2.2.3 Appellant III argued that some of the compounds of the aqueous phase 20 in D6 were defined in a functional way (water soluble chelator, colours, preservatives, an UV inhibitor). It followed that the viscosity of said phase was speculative since the viscosity was dependent on the specific compound which was chosen as chelator, colour, preservative and UV inhibitor.

2.2.4 For the board, in the absence of substantive evidence to support these allegations, this argument does not hold. Notwithstanding, in view of the very low amounts of preservatives (0.25 wt.%), UV protectant (0.1 wt.%) and colors (trace) present in the aqueous phase 20, there is no reason to believe that the viscosity thereof could be higher than 30 cps.

2.2.5 It follows from the above that document D6 does not literally disclose that the three phases are pumped into the blending tube at a flow rate of from 5 to 5,000 pounds/minute (phase (i) has a flow rate of about 4.6 pounds/minute).

- 2.3 According to the contested patent (paragraph [0001]), the problem was to provide a process for manufacturing liquid personal care compositions which minimises equipment requirements, increases capacity and reduces manufacturing times. Paragraph [0009] further discloses that the holding/blending tank can be significantly downsized.
- 2.4 As a solution to this problem, the contested patent proposes the process according to claim 1 at issue, which is in particular *characterised in that* the three phases are all mixed together, with each of the phases being pumped into the blending tube as a liquid stream at a pressure from 10 to 5,000 psi and at a flow rate of 2.274 to 2,270 kg (5 to 5,000 pounds) per minute.
- 2.5 As to the success of the proposed solution, for the board, the problem identified in point 2.3 above is not solved on the whole breadth of the claim because, in comparison to document D6, the downsizing of the equipment, in particular of the holding tank, is only achievable with phase (iii) and only when this phase is water - i.e. without any additive - and when the water is directly pumped into the blending tube from a well or a municipal water carrier.

For the other alleged improvements mentioned in paragraphs [0001] and [0009] ) (capacity increase, reduction of manufacturing time, reduction of water in the first phase, reduction of the mixing equipment, reduction of the tank space), no evidence is on file or can be found in the contested patent.

It follows from the above considerations that the problem identified in point 2.3 cannot be held to be solved, with the consequence that it has to be

reformulated in the light of D6 into the provision of an alternative process for manufacturing liquid personal care products.

2.6 As to the question of obviousness, it has to be determined whether the proposed solution was obvious in the light of the state of the art, in particular document D5.

2.6.1 The board notes in this respect that, as argued by appellant III/proprietor, document D5 does not directly concern the production of a liquid personal care composition but of a protein-containing food product, such as cheese (see examples).

2.6.2 The question arises whether the skilled person would find a hint in document D5 that a liquid personal care composition can be prepared by mixing together three liquid phases in a blending tube at a pressure from 10 to 5,000 psi and at a flow rate of 2.274 to 2,270 kg (5 to 5,000 pounds) per minute.

Appellant III argued that the skilled person would not consider document D5 at all. The board cannot accept this argument. In the present context, it is recalled that an alternative process is sought.

For the board, a hint is unambiguously given to the skilled person in document D5, which discloses that a coagulum can be produced by mixing **three liquid phases** in a sonic chamber 64 of an ultrasonic device 46 (column 4, line 45 to column 5, line 8 and Figure 2, reproduced below), the so-called "blending tube" of claim 1 at issue.



2.6.3 D5 further discloses in its examples that the sonic device is a Sonolator operating at a pressure of from 400 psi to 800 psi. At column 3, lines 13 to 19, the sonic device is moreover described as having been currently used to mix, homogenize, disperse and emulsify various compounds in the **cosmetic** industry. So, D5 clearly teaches the possibility of preparing a liquid personal care composition by mixing together under pressure three liquid phases (52, 48, 54) in a Sonolator.

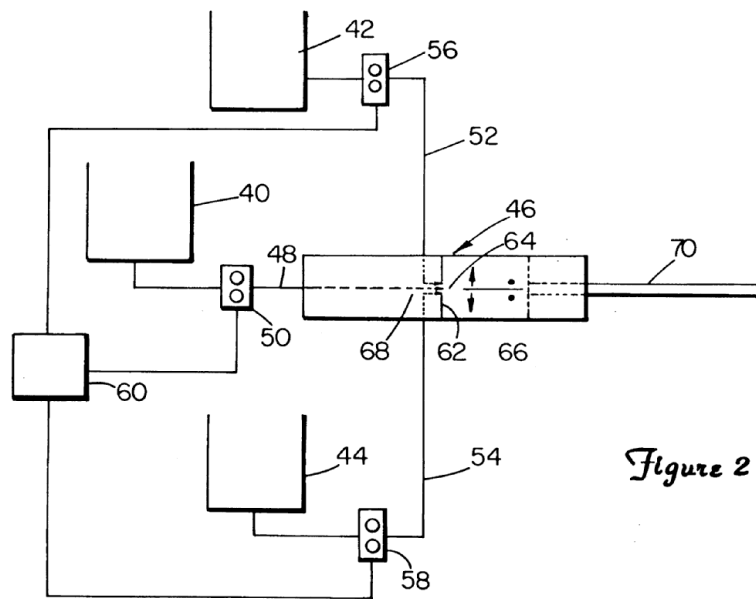

*Figure 2*

2.6.4 It is true that neither of the documents D5 or D6 describes the flow rate of the third phase as higher than 5 pounds per minute, as required by claim 1 at issue.

D6 discloses the flow rate of the third phase to be 2.1 kg/min, i.e. 4.6 pounds/minute. For the board, this minor difference between the claimed subject-matter and the prior art disclosure cannot however be regarded as involving an inventive step, because in D6 the other

two phases are pumped at flow rates of 15.6 kg/min (i.e. about 33 pounds/min) and 24.5 kg/min (i.e. about 52 pounds/min), respectively, i.e. at flow rate values which directly and unambiguously fall within the ranges of pressure and flow rate as defined in claim 1 at issue.

As there is, furthermore, no evidence at all in the contested patent that the selected range of flow rates provided for any particular effect or advantage, the choice of a flow rate slightly higher than the actual value of 4.6 pounds/min is, for the board, well within the competence of a skilled person seeking an alternative process to the one known from document D6.

2.7 It follows from the above considerations that, having regard to the teachings of documents D6 and D5, the skilled person seeking an alternative process for preparing a liquid personal care composition would arrive in an obvious manner at the subject-matter of claim 1, which therefore does not involve an inventive step within the meaning of Article 56 EPC.

3. Auxiliary request 1 - inventive step

Claim 1 of auxiliary request 1 is the independent claim 1 of the set of claims on which the opposition division proposed to maintain the patent. Its subject-matter differs from that of claim 1 as granted in that the mixing of the phases is "**by sonic agitation**".

For the board, this feature does not provide any inventive contribution to the claimed subject-matter, since in the processes of documents D5 and D6, the mixing of the phases is likewise done by sonic agitation with the consequence that the reasons in

points 2.1 to 2.6.4 apply *mutatis mutandis* to claim 1 of this request, which therefore does not meet the requirements of Article 56 EPC.

4. Auxiliary request 2 - inventive step

Claim 1 of this request differs from claim 1 as granted in that the phases are **separately** pumped into the blending tube.

For the board, this feature does not provide any inventive contribution to the claimed subject-matter, since in the process of document D6, the phases are pumped in this way into the Sonolator 46 (see Figure 2 above), with the consequence that the reasons in points 2.1 to 2.6.4 apply *mutatis mutandis* to claim 1 of this request, which therefore does not meet the requirements of Article 56 EPC.

5. Auxiliary request 3 - inventive step

Claim 1 of this request differs from claim 1 as granted in that the blending tube **is a Sonolator**.

For the board, this feature does not provide any inventive contribution to the claimed subject-matter, since in the process of both documents D5 and D6, the "blending tube" is a Sonolator, with the consequence that the reasons in points 2.1 to 2.6.4 apply *mutatis mutandis* to claim 1 of this request, which therefore does not meet the requirements of Article 56 EPC.

6. Auxiliary request 4 - inventive step

Claim 1 of this request differs from claim 1 as granted in that the lower pressure of the range defined in the

claimed subject-matter has been modified into 150 psi (instead of 10 psi in claim 1 as granted).

For the board, this amendment does not provide any inventive contribution to the claimed subject-matter, since in the processes of both documents D5 and D6, the pressure by which the phases are pumped into the Sonolator is definitely within this range (in D5, the Sonolator is described in the examples as operating at a pressure of from 400 psi to 800 psi (see point 2.6.3 above); in the example of D6 (see column 11, lines 13 to 16) the Sonolator operates at a pressure of about 350 psig), with the consequence that the reasons in points 2.1 to 2.6.4 apply *mutatis mutandis* to claim 1 of this request, which therefore does not meet the requirements of Article 56 EPC.

7. Auxiliary request 5 - inventive step

The amendments to claim 1 of this request correspond to the combination of the amendments to the respective claims 1 of auxiliary requests 1 and 2, namely that the phases are "**separately**" pumped into the blending tube and the phases are mixed "**by sonic agitation**".

For the board, these amended features do not provide any inventive contribution to the claimed subject-matter, since as indicated at points 3. and 4., they are also disclosed in the processes of documents D5 and/or D6, with the consequence that the reasons in points 2.1 to 2.6.4 apply *mutatis mutandis* to the subject-matter of claim 1 of this request, which thus does not meet the requirements of Article 56 EPC.

8. Auxiliary request 6 - inventive step

Claim 1 of this request corresponds to that of auxiliary request 1, to which the following feature has been added at the end: "***viscosities being measured with a Brookfield RVT Viscometer, Spindle No. RV6 at 20 rpm for 1 minute at 25°C.***"

For the board, this amendment does not provide any inventive contribution to the claimed subject-matter, since it simply defines the method by which the viscosities have been measured. This method being the method by which the measurements referred to in document D18 (see point 2.2.2 above) have been made, the reasons indicated in points 2.1 to 2.6.4 above apply *mutatis mutandis* to the subject-matter of claim 1 of this request, which thus does not meet the requirements of Article 56 EPC.

9. Auxiliary request 7 to 10 - inventive step

Claim 1 of auxiliary requests 7, 8, 9 and 10 corresponds to claim 1 of auxiliary requests 2, 3, 4 and 5, respectively, **as amended in the same manner as claim 1 of of auxiliary request 6.**

As explained in point 8. above, this amendment merely defines the method by which the viscosities have been measured and, for the same reasons as those indicated in points 2.1 to 2.6.4, it does not provide any inventive contribution to the claimed subject-matter, which therefore lacks inventive step under Article 56 EPC.

10. It follows from the above conclusions that none of appellant's III requests meets the requirements of the EPC.

**Order**

**For these reasons it is decided that:**

1. The decision under appeal is dismissed.
2. The patent is revoked.

The Registrar:

The Chairman:



C. Vodz

G. Rath

Decision electronically authenticated