

**Internal distribution code:**

- (A) [ - ] Publication in OJ  
(B) [ - ] To Chairmen and Members  
(C) [ - ] To Chairmen  
(D) [ X ] No distribution

**Datasheet for the decision  
of 9 October 2014**

**Case Number:** T 1893/11 - 3.3.05

**Application Number:** 04755308.6

**Publication Number:** 1638690

**IPC:** B01L3/14

**Language of the proceedings:** EN

**Title of invention:**

APPARATUS AND METHOD FOR HANDLING FLUIDS FOR ANALYSIS

**Applicant:**

ABBOTT LABORATORIES

**Headword:**

Reaction vessel/ABBOTT

**Relevant legal provisions:**

EPC Art. 54(1), 54(2), 123(2)

**Keyword:**

Novelty - main and first auxiliary request (no)  
Amendments - second auxiliary request - added subject-  
matter (yes)

**Decisions cited:**

**Catchword:**



**Beschwerdekammern  
Boards of Appeal  
Chambres de recours**

European Patent Office  
D-80298 MUNICH  
GERMANY  
Tel. +49 (0) 89 2399-0  
Fax +49 (0) 89 2399-4465

Case Number: T 1893/11 - 3.3.05

**D E C I S I O N**  
**of Technical Board of Appeal 3.3.05**  
**of 9 October 2014**

**Appellant:** ABBOTT LABORATORIES  
(Applicant) 100 Abbott Park Road  
Abbott Park, IL 60064-3500 (US)

**Representative:** Modiano, Micaela Nadia  
Modiano Josif Pisanty & Staub Ltd  
Thierschstrasse 11  
80538 München (DE)

**Decision under appeal:** **Decision of the Examining Division of the  
European Patent Office posted on 8 April 2011  
refusing European patent application No.  
04755308.6 pursuant to Article 97(2) EPC.**

**Composition of the Board:**

**Chairman** G. Raths  
**Members:** J-M. Schwaller  
C. Vallet

## Summary of Facts and Submissions

I. This appeal lies from the decision of the examining division refusing European patent application No. 04 755 308.6 because the claims of the three requests dated 4 March 2011 lacked novelty under Article 54(1)(2) EPC in view of the disclosure of document

D4: EP 1 025 902.

II. With the grounds of appeal dated 18 August 2011, the appellant filed a new main request with claim 1 thereof reading as follows:

*"1. A reaction vessel (26c) for testing an analyte in a fluid, comprising a vessel having an open top and a drain opening (92c) in its bottom, said drain opening being adapted to support a selected head of fluid and to drain fluid therethrough when a selected pressure differential exists between the top of the fluid and the bottom of the vessel, characterized in that it further comprises a hydrophobic frit (99) associated with said vessel (26c) to define the drain opening (92c), said hydrophobic frit being selected based on said fluid, such that where a fluid having low surface tension properties is used, the porosity of the frit material is less than the material used with fluids having higher surface tension properties and adapted to support a desired height of fluid in the vessel and to allow the fluid to pass therethrough when a selected pressure differential is introduced between the top of the vessel and beneath said frit and drain opening."*

III. In a communication dated 26 November 2013, the board expressed its preliminary opinion that above claim 1

did not appear to meet the requirements of Articles 83, 84 and 54(1) (2) EPC.

IV. With letter of 7 April 2014, the appellant submitted a set of observations contesting the board's preliminary opinion and it maintained the main request on file. Further it filed two new sets of claims as first and auxiliary requests, with the respective claims 1 reading as follows:

First auxiliary request (differences to the main request emphasised by the board):

"1. A reaction vessel (26c) for testing an analyte in a fluid, comprising a vessel having an open top and a drain opening (92c) in its bottom, said drain opening being adapted to support a selected head of fluid and to drain fluid therethrough when a selected pressure differential exists between the top of the fluid and the bottom of the vessel, **said vessel further comprising** ~~characterized in that it further comprises a~~ **porous** hydrophobic frit (99) associated with said vessel (26c) to define the drain opening (92c)."

Second auxiliary request (differences to the main request emphasised by the board):

"1. A reaction vessel (26c) for testing an analyte in a fluid, comprising a vessel having an open top and a drain opening (92c) in its bottom, said drain opening being adapted to support a selected head of fluid and to drain fluid therethrough when a selected pressure differential exists between the top of the fluid and the bottom of the vessel, characterized in that **the reaction vessel** ~~[[it]]~~ further comprises a **first** hydrophobic frit (99) **capable of being** associated with

*said vessel (26c) to define the drain opening (92c), said **first hydrophobic frit having a first degree of porosity and** being selected **to define the draining opening when** ~~based on said fluid, such that where a fluid having low surface tension properties is used,~~ **and a second hydrophobic frit interchangeable with said first hydrophobic frit and capable of being associated with said vessel to define the drain opening, said second hydrophobic frit having a second degree of porosity and being selected to define the drain opening when a fluid having a high surface tension properties is used,** the **first degree of porosity of the first hydrophobic frit being** ~~material is less than the~~ **second degree of porosity of the second hydrophobic frit material** used with fluids having higher surface tension properties and adapted to support a desired height of fluid in the vessel and to allow the fluid to pass therethrough when a selected pressure differential is introduced between the top of the vessel and beneath said frit and drain opening."*

The appellant further requested that the decision under appeal be set aside and that the case be remitted to the first instance with the order to grant a patent on the basis of one of the sets of claims on file.

- V. In response to a summons to attend oral proceedings, the appellant informed the board with a letter dated 30 September 2014 that it withdrew its request for oral proceedings and that it requested a decision according to the state of the file.
- VI. With letter of 7 October 2014, the board cancelled the appointed oral proceedings.

## Reasons for the Decision

1. Preliminary remark

The appellant having withdrawn its request for oral proceedings and requested a decision according to the state of the file, a final decision can be issued.

2. Main request - novelty of claim 1

For the board, the disclosure of document D4 is novelty-destroying for the subject-matter of claim 1 at issue in the following respects:

2.1 First of all, it is to be noted that the feature in claim 1 which defines the **hydrophobic frit** as being

*"selected based on said fluid, such that where a fluid having low surface tension properties is used, the porosity of the frit material is less than the material used with fluids having higher surface tension properties"*

has **no limiting effect on the claimed subject-matter**, because it defines the porosity of the frit material with respect to two fluids:

a first one having "low surface tension properties" and a second one having "high surface tension properties", without further defining the fluids and without defining how the porosity of the frit material is to be selected in view of the respective surface tension properties of the fluids.

For the board, it follows from the above missing information in the definition of the porosity of the

frit material that no tangible technical limitation can be attributed to this part of the claimed subject-matter.

2.2 The **other features** of claim 1 at issue are disclosed in the following respects in D4:

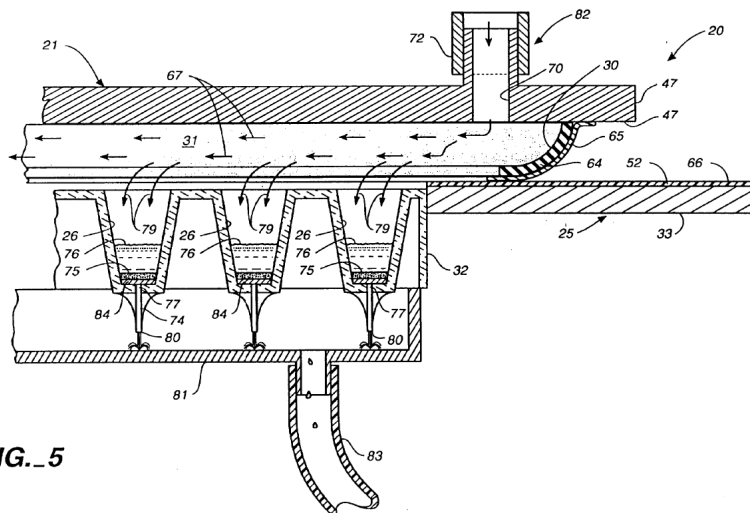

FIG. 5

In Figure 5 (see above), D4 discloses an apparatus (for polymer synthesis) provided with reaction wells (26) having an orifice (74) extending into the well which further contains a reagent solution (76) and a solid support (75) on which is fixed at least one polymer unit. The orifice (74) is of a size and dimension to form a capillary liquid seal to retain the reagent solution in the well.

In the bottom of the well, between the orifice (74) and the solid support (75), is located a device (84), preferably a polyethylene or glass fiber frit, which acts as a filter membrane permitting the reagent solution to flow therethrough while retaining the solid support and polymer chain grown thereon in the well.

D4 thus discloses the following structural **features of the device** defined in claim 1 at issue:

- a reaction vessel (in D4, the well (26)) having:
- an open top (in D4, see Figure 5),
- a drain opening (in D4, the orifice (74)) in its bottom adapted to support a selected head of fluid (in D4, the reagent solution (76)), and
- a frit (in D4, the polyethylene frit (84)) in the drain opening. Polyethylene being hydrophobic, a "hydrophobic frit" in the sense of claim 1 at issue is thus disclosed in D4.

D4 (page 8, lines 6 to 11) further discloses that the **porosity** of the frit (84) contributes to the formation of the capillary liquid seal for retaining the reagent liquid and to the pressure differential necessary for purging the reaction well. The frit (84) is thus adapted "*to support a desired height of fluid in the vessel and to allow the fluid to pass therethrough when a selected pressure differential is introduced between the top of the vessel and beneath said frit and drain opening*" in the sense of claim 1 at issue.

D4 (page 8, lines 27 to 29) also discloses that the liquid reaction solution will not leak out of or be purged from the well orifice (74) until there is a sufficient head of liquid in the well or a sufficient gas **pressure differential** between the common chamber (31) and the lower catch basin (81) to overcome the capillary forces in the orifice. The orifice (74) is thus adapted "*to drain fluid therethrough when a selected pressure differential exists between the top of the fluid and the bottom of the vessel*" in the sense of claim 1 at issue.



2.3 It follows from the above considerations that the subject-matter of claim 1 at issue, understandable in terms of concrete technical features, is disclosed in document D4, and so claim 1 lacks novelty under Article 54(1)(2) EPC, with the consequence that the main request is not allowable.

3. First auxiliary request - novelty

3.1 Claim 1 of this request differs from that of the main request by the introduction of the feature "porous" and the deletion of the expression: *"said hydrophobic frit being selected based on said fluid, such that where a fluid having low surface tension properties is used, the porosity of the frit material is less than the material used with fluids having higher surface tension properties and adapted to support a desired height of fluid in the vessel and to allow the fluid to pass therethrough when a selected pressure differential is introduced between the top of the vessel and beneath said frit and drain opening."*

3.2 For the board, the above amendments do not provide novelty, because the frit in D4 is also defined as being porous (see in particular the passage at page 8, lines 6 to 11, of D4, which refers to the "porosity of the frit"). As indicated in point 2.2 above, the other features now defined in claim 1 are all disclosed in combination in document D4.

3.3 It follows that the subject-matter of claim 1 at issue lacks novelty under Article 54(1)(2) EPC, with the consequence that the first auxiliary request is not allowable.

4. Second auxiliary request - compliance with Article 123(2) EPC.
- 4.1 The board considers that the amendments made in claim 1 of this request have no basis in the application as filed. In particular, no reference could be found in the original application documents for the features "*a first hydrophobic frit having a first degree of porosity*", a "*second hydrophobic frit having a second degree of porosity*" and being "*interchangeable with said first hydrophobic frit*".
- 4.2 The appellant argued that support for the above amendments was provided in the following passage on page 14 of the application as filed in the version published as WO 2004/113874: "*The hydrophobic frit 99 may be advantageously selected, based on the fluid, whereby the frit 99 will support the desired height of fluid 90 in vessel 26c, and will allow the fluid to pass therethrough when a selected pressure differential is introduced between the top of the vessel 26c and beneath the frit 99/drain opening 92c. Thus, where a fluid having low surface tension properties is used (e.g. alcohol), the porosity of the frit material may advantageously be less than the material used with fluids having higher surface tension properties to enable the desired height of fluid to be supported as desired.*"  
  
In particular it argued that the terms "*first*" and "*second*" frit were "*silently implied*" by the sentence "*Thus ... desired.*").
- 4.3 The board does not accept these arguments because, even if the terms "*first*" and "*second*" were implied by the said sentence (which the board is not convinced of),

there is definitely no basis in the application as filed for the interchangeability of said first and second frit.

4.4 It follows from the above considerations that claim 1 at issue does not meet the requirements of Article 123(2) EPC, with the consequence that the second auxiliary request is not allowable.

4.5 As none of the requests on file fulfils the requirements of the EPC, the appeal must be dismissed.

## Order

### **For these reasons it is decided that:**

The appeal is dismissed.

The Registrar:

The Chairman:



C. Vodz

G. Rath

Decision electronically authenticated