

Internal distribution code:

- (A) [-] Publication in OJ
- (B) [-] To Chairmen and Members
- (C) [-] To Chairmen
- (D) [X] No distribution

**Datasheet for the decision
of 17 November 2017**

Case Number: T 1485/11 - 3.5.01

Application Number: 08782367.0

Publication Number: 2176774

IPC: G06F13/42

Language of the proceedings: EN

Title of invention:

CONFIGURING MULTI-BIT SLAVE ADDRESSING ON A SERIAL BUS USING A
SINGLE EXTERNAL CONNECTION

Applicant:

Microchip Technology Incorporated

Headword:

Multifunctional pin / Microchip Technology

Relevant legal provisions:

EPC Art. 56

RPBA Art. 12(2), 13

Keyword:

Inventive step - multiplexing address setting and IC function on single pin (no - obvious consideration) - internal instead of external pull up (or pull down) resistor (no - obvious consideration) - isolate internal resistor after address setting (no - obvious possibility for inevitable aspect of implementation)



Beschwerdekammern
Boards of Appeal
Chambres de recours

Boards of Appeal of the
European Patent Office
Richard-Reitzner-Allee 8
85540 Haar
GERMANY
Tel. +49 (0)89 2399-0
Fax +49 (0)89 2399-4465

Case Number: T 1485/11 - 3.5.01

D E C I S I O N
of Technical Board of Appeal 3.5.01
of 17 November 2017

Appellant: Microchip Technology Incorporated
(Applicant) 2355 West Chandler Boulevard
Chandler, AZ 85224-6199 (US)

Representative: Grubert, Andreas
c/o Westphal, Mussnug & Partner
Patentanwälte mbB
Werinherstraße 79
81541 München (DE)

Decision under appeal: **Decision of the Examining Division of the
European Patent Office posted on 11 February
2011 refusing European patent application No.
08782367.0 pursuant to Article 97(2) EPC.**

Composition of the Board:

Chairman W. Chandler
Members: P. Scriven
Y. Podbielski

Summary of Facts and Submissions

- I. The Examining Division refused European patent application 08782367.0 *inter alia* for lack of inventive step in consideration of the teaching of document D1 (*BL310 - I2C Versatile Relay Driver*). This is the appeal against that decision.
- II. With the statement setting out its grounds of appeal, the appellant requested that the Examining Division's decision be set aside and that a patent be granted on the basis of a new set of claims and also that oral proceedings be held. The appellant submitted that the Examining Division, in basing its decision on document D1 rather than document D5 (EP-A 1355426), committed a procedural violation and that the appeal fee should be refunded.
- III. The Board arranged to hold oral proceedings and set out its provisional view in a communication sent with the summons. The Board saw no procedural violation in the decision based on D1, but found it preferable to consider the question of inventive step starting from D5. The central question seemed to be whether the skilled person would have considered using one pin of an IC package for more than one purpose. The Board also indicated some issues of clarity and disclosure.
- IV. The appellant submitted no written response, but was represented at oral proceedings. The request for reimbursement of the appeal fee was withdrawn. After the debate as to inventive step in respect of claim 1 according to the main request, the appellant submitted an auxiliary request.

V. Claim 1 according to the main request reads:

An integrated circuit device adapted for coupling to a serial data bus (126), comprising:

serial interface and control logic (114), the serial interface and control logic (114) having an input coupled to a first connection pin (124);

an analog-to-digital converter (ADC) (110);

an address register (112) having data inputs coupled to respective digital outputs of the ADC (110) and an address detection control input coupled to the serial interface and control logic (114), wherein logic levels on the respective digital outputs of the ADC (110) are stored in the address register (112) when the serial interface and control logic (114) applies an address detection signal to the address detection control input during an address detection operation;

characterized by

a second external connection pin (120) which is used in a first operation mode of the device for programming one of a plurality of addresses into the device (102) and in a second operation mode of the device (102) to perform a function other than said address programming function, a function unit (104) for performing said function;

an internal pull-up or pull down resistor (116); and
a switch (106) for switching between said first and second operation mode, said switch (116) being coupled to the second external connection pin (120), to an input of the ADC (110), to the function unit (104), to said internal pull-up or pull-down resistor (116) and to a control port coupled to the serial interface and control logic (114), wherein during the first operation mode the switch (116) is controlled to couple the second external connection pin (120) with the internal pull-up or pull-down resistor (116) and the input of the ADC (110) and during the second operation mode the switch (116) is controlled to disconnect the internal pull-up or pull-down resistor (116) and the ADC (110) from the second external connection pin (120) and couple the function unit (104) with the second external connection pin (120);
wherein the serial interface and control logic (114) causes the switch (106) to operate in the first operation mode, wherein the internal pull-up or pull down resistor (116) forms a voltage divider with another resistor (118) connected externally to the second connection pin (120), and
wherein the ADC converts an analog value determined by said voltage divider to a multi-bit digital address that is stored in the address register(112); and
thereafter the serial interface and control logic (114) controls the switch (106)

according to the second operation mode.

- VI. Claim 1 according to the auxiliary request comprised a number of clarifications and corrections. In substance, however, it amounted to claim 5 of the main request.
- VII. The appellant's substantive arguments can be summarised as follows:

It was essential to the invention that both the programming of an address and some other function use the same pin. Programming a first address should not be considered a different function from programming a second, however: the other function was something other than address programming.

Pin A0 of D1 could not be used for any other purpose than setting the address; and D1 did not disclose an analogue to digital converter. There was no basis in D1, even in combination with D4, for the assertion that it was normal design practise to use a switch to allow one pin to have more than one function. D4 did not disclose a switch.

D5 did disclose the use of one pin, a voltage divider, and an ADC for setting a device's address, but did not disclose the pin's use for any other purpose. D5 presented itself as a self-contained solution to the problem of reducing a package's pin count, so the skilled person would not consider making further changes. If, however, the skilled person did consider using the address pin for some other purpose, the invention would still not have been obvious because there were three differences over D5, too many to be obvious. The three differences were: the pin was used for some other purpose in addition to programming the

device's address; the pin was connected via a switch either to the analogue to digital converter or to the functional unit; and one of the external resistors disclosed in D5 was now internal to the IC package and the switch disconnected it, when the pin was connected to the functional unit. The effect of having the resistor inside was that it could be disconnected, which increased flexibility.

Reasons for the Decision

The invention

1. The invention is about integrated circuit devices connected to a serial computer bus. Several devices can be connected to the bus, but data are normally intended for only one of them and are, therefore, sent with an address that identifies the intended recipient. The device's address is held in a register, and the device compares the address sent with incoming data with the address stored in its register. The invention is about how a device's address can be written into its register.
2. One way of programming an address with N bits is to provide N input pins, to read the bits from those pins, and to write them to the register. That, however, would require too many pins, and the invention takes a different approach.

3. The invention uses a single pin. Rather than receiving a binary value, this pin receives an analogue voltage. An analogue to digital converter (ADC) converts the analogue voltage to the digital address.
4. The invention does more, however. The device's address is programmed only occasionally. Most of the time, the device performs whatever function it is connected to the bus for. It might control a fan, for example, or take temperature readings. At those times, the address pin is disconnected from the ADC and is connected to the "functional unit" (FU), that is, to the unit that controls the fan or reads the temperature.
5. The analogue voltage used to set the address is formed using a pair of resistors that form a voltage divider. One of them is internal to the device; the other is external and has to be chosen by the device's user so as to provide the correct voltage for the desired address. When the pin is connected to the FU and disconnected from the ADC, it is also disconnected from the internal resistor.

Inventive step

6. The appellant acknowledges that D5 discloses the programming of an address by presenting an analogue voltage at one pin. The voltage is produced by a voltage divider and is converted to a digital address by an ADC. This is all evident from Figure 1.
7. The Board agrees with the appellant's account of the way the invention differs: the address pin is used for some other function, when not being used for setting the address, and is switched either to the ADC or to the FU

accordingly; one of the resistors of the voltage divider is internal to the device rather than external; and the address pin is disconnected from the internal resistor when not in the address-setting mode.

8. The multifunctional use of the pin helps keep the pin count small. The relocation of the resistor from external to internal makes the device easier to deploy. These are independent problems. (The third difference means the solutions to these problems are not independent, but this is considered in detail in paragraphs 14 - 17, below.)
9. Keeping the pin count of IC packages small was a well known problem and using a pin for more than one function was a well known approach. D4 shows a rather general way of allowing pins to have more than one function; and D3 shows that it was known in connection with I²C devices (see, for example, pins MFP0 - MFP3 in the table on page 5). The appellant, correctly, did not contest this point.
10. The appellant did, however, argue that D5 already provided a solution to the problem of keeping the pin-count small, and that the skilled person would have had no motivation to make further changes. That is not an argument the Board can accept. D5 concentrates on the setting of the device's address and the number of pins needed to do that; but there is nothing to stop the skilled person seeking further reductions in the package's pin count. In the Board's view, that is just what she would do, because pin-count is always an issue in this field.
11. The use of a switch to provide a selective connection is basic. It is what switches are for.

12. The convenience of providing a package with an internal resistor was also a well known measure. D1, for example, provides an internal pull-up resistor so that it is not necessary to provide one externally (D1, section 3.6).
13. The Board, therefore, considers that it would have been obvious to use a switch to provide the address pin with a second function and to move one of the resistors into the package.
14. As to the position of the internal resistor, it is so arranged that it is disconnected from the address pin when the pin is used for its second function. This introduces an interaction between the solutions to the two problems. Given that the skilled person has decided to use a switching arrangement and to move the resistor inside, would it have been obvious to make this further arrangement? It is a question that must be addressed with some care. The danger is hindsight.
15. The arrangement with the switch looks like this.

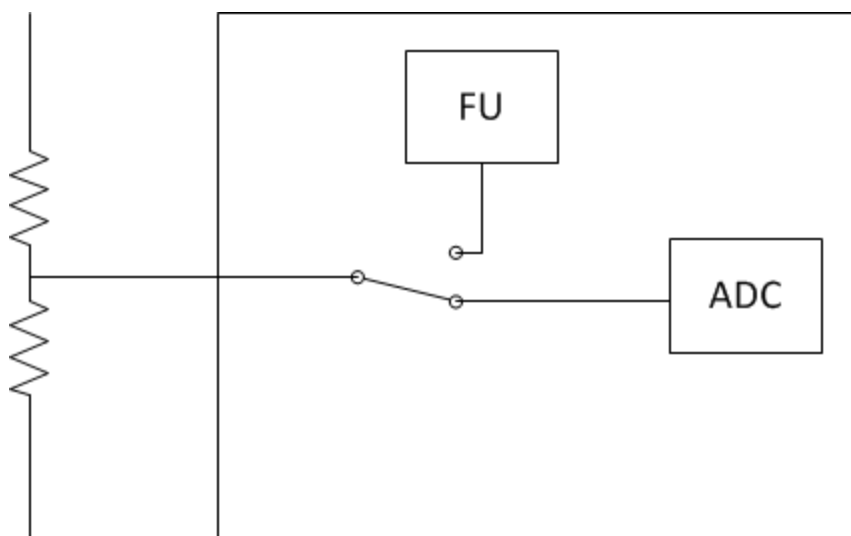

The lower (say) of the two resistors is to be moved inside. There are two possibilities, A and B.

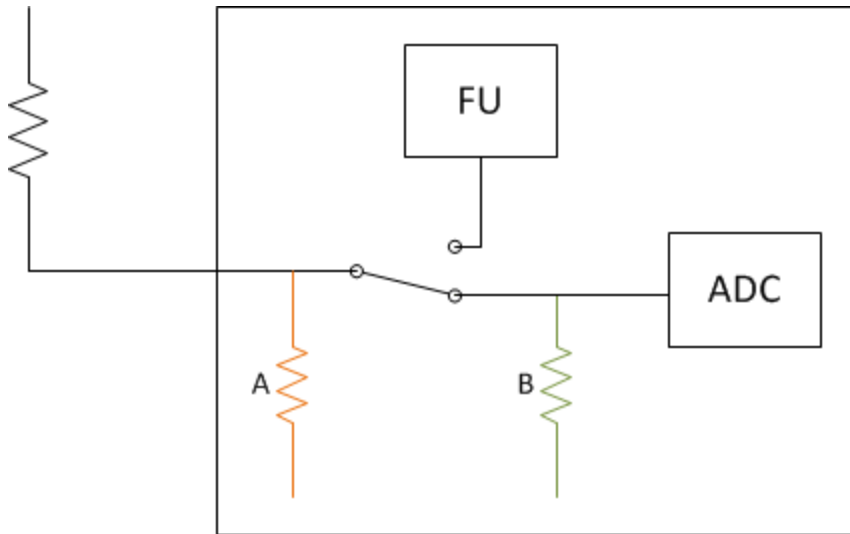

16. It is not open to the skilled person to leave the choice unmade. She has to make a working device, and, in any particular implementation, she must choose either A or B. There will be cases in which the FU needs a resistor connected, cases in which there must be no resistor, and cases in which it does not matter. She will choose accordingly. That is a matter of what the FU does and how it does it, and the application is silent as to those issues. The skilled person will note, at least, that no current will flow through resistor B when the address is not being set (this effect is noted in the paragraph bridging pages 9 and 10 of the published application).

17. In the Board's view, this kind of consideration is the skilled person's bread and butter, as a matter of basic electronic design. She can easily see the choices to be made and knows the considerations involved. Therefore, there is no hindsight in drawing the conclusion that the skilled person would understand that position B be best or even necessary in some cases. But B is the invention.

18. The claimed device, therefore, does not involve an inventive step (Article 56 EPC) and the main request cannot be allowed.

The auxiliary request

19. The statement of grounds of appeal must set out a party's whole case (Article 12(2) RPBA). With respect to D5, the appellant's case was that the arrangement of switch and internal resistor would not have been obvious.
20. The auxiliary request removes the definition of the internal resistor being either *pull-up* or *pull-down*. That addresses an objection raised in the Board's provisional opinion. However, the Board sees no reason why this simple amendment should be submitted only during oral proceedings and only after the discussion of the main request. In addition, it does not seem to affect the issue of inventive step.
21. There is a more substantial addition to the claim, however, that defines the circumstances under which the device's address is set. This was not part of the appellant's original case and takes the question of inventive step in a different direction. The day of oral proceedings is too late for that.
22. The appellant's representative argued that discussion with the appellant as to what fall-back positions might be taken if the decision on the inventive step were not favourable had only been possible shortly before oral proceedings. The Board cannot accept this. The appellant has to ensure that submissions are made in good time.

23. The Board, therefore, declines to admit the auxiliary request (Article 13 RPBA).

Order

For these reasons it is decided that:

The appeal is dismissed.

The Registrar:

The Chairman:



T. Buschek

W. Chandler

Decision electronically authenticated