

Internal distribution code:

- (A) Publication in OJ
(B) To Chairmen and Members
(C) To Chairmen
(D) No distribution

**Datasheet for the decision
of 28 September 2011**

Case Number: T 1695/07 - 3.3.07
Application Number: 95902560.2
Publication Number: 781161
IPC: B01D 61/32, A61M 1/36
Language of the proceedings: EN

Title of invention:

Blood flow measurement method in hemodialysis shunts

Patent Proprietors:

TRANSONIC SYSTEMS, INC.

Opponents:

Fresenius Medical Care Deutschland GmbH

Headword:

-

Relevant legal provisions:

EPC Art. 53(c), 56, 111(1), 123(2)

Relevant legal provisions (EPC 1973):

EPC Art. 52(4), 84

Keyword:

"Exception to patentability (yes) - Main Request and Auxiliary Request 1"

"Disclaimer admissible (no) - Auxiliary Request 2"

"Exception to patentability (no) - apparatus - Auxiliary Requests 3 and 4"

"Amendments - Clarity (no) - Auxiliary Requests 3 and 4"

"Amendments - allowable (yes) - Auxiliary Request 5"

"Inventive step (yes) - non obvious solution - Auxiliary Request 5"

"Remittal (yes) - description yet to be adapted"

Decisions cited:

G 0001/07, G 0001/04, G 0001/03, G 0002/03, T 0182/90,
T 0035/99, T 0663/02, T 0329/94, T 0067/02, T 0712/93,
T 0775/97, T 1075/06

Catchword:

I. A blood manipulation process involving the continuous removal of blood from a patient, its subsequent flowing through a circulating line of an extracorporeal circuit and its re-delivery to the patient is a method of treatment of the human body by surgery excepted from patentability under Article 53(c) EPC. It does not belong to the kind of methods which should not be covered by the exception clause according to the "narrower understanding" suggested by the Enlarged Board of Appeal in decision G 1/07, because the process is not performed in a "non-medical, commercial environment" and cannot be considered as a "minor intervention" being performed on "uncritical parts of the body" (Reasons, 8 to 10).

II. Such an in vivo process requires "professional medical expertise" and belongs to the kind of interventions representing the "core of the medical profession's activities", even when performed by paramedical support staff (Reasons, 11).

III. Even when the process is carried out with the required medical professional care and expertise, it involves "substantial health risks" for the patient. A health risk is considered to qualify as "substantial" whenever it goes beyond the side effects associated with treatments such as tattooing, piercing, hair removal by optical radiation, micro abrasion of the skin as mentioned in G 1/07. A factual analysis of absolute or relative risks and their likelihood of occurrence based on objective evidence is hardly feasible and should therefore not be required (Reasons, 12).



Case Number: T 1695/07 - 3.3.07

DECISION
of the Technical Board of Appeal 3.3.07
of 28 September 2011

Appellants I: TRANSONIC SYSTEMS, INC.
(Patent Proprietors) 34 Dutch Mill Road
Ithaca, NY 14850-9787 (US)

Representative: Harrison, David Christopher
Mewburn Ellis LLP
33 Gutter Lane
London EC2V 8AS (GB)

Appellants II: Fresenius Medical Care Deutschland GmbH
(Opponents) Else-Kröner-Straße 1
D-61352 Bad Homburg (DE)

Representative: Herrmann, Uwe
Lorenz - Seidler - Gossel
Widenmayerstraße 23
D-80538 München (DE)

Decision under appeal: Interlocutory decision of the Opposition
Division of the European Patent Office posted
24 July 2007 concerning maintenance of the
European patent No. 781161 in amended form.

Composition of the Board:

Chairman: J. Riolo
Members: G. Santavicca
C. Körber
P. Schmitz
D. Keeling

Summary of Facts and Submissions

I. Two appeals (by the patent proprietors and by the opponents) lie from the decision of the Opposition Division maintaining the European patent N° 0 781 161 (granted on European patent application N° 95 902 560.2, originating from international application N° PCT/US94/13163 published as WO 96/08305) in the amended form based on the patent proprietors' auxiliary request. The decision under appeal also gave the reasons for refusing the Main Request (patent as granted).

II. The patent as granted contained 15 claims, the independent process and apparatus claims reading as follows:

"1. A process for measuring the rate of blood flow in a shunt (12) in which blood is flowing, comprising:

continuously removing blood from a downstream location in the shunt (12) by way of an inlet (28) to an inlet side (26) of a circulating line;

delivering the removed blood flowing in said circulating line by way of an outlet (34) connected to an outlet side (32) of said circulating line to an upstream location of said shunt (12), so as to cause it to travel downstream in the shunt (12) towards the inlet (28) as an admixture with the blood flow;

changing a selected physical property of the blood in said circulating line to produce a distinguishable blood characteristic at the outlet side (32) of said circulating line;

measuring the amount of change of said distinguishable blood characteristic; and

determining the rate of blood flow in said shunt (12) from the amount of change of said distinguishable blood characteristic by reference to a dilution curve of said amount of change."

"9. Apparatus for measuring the rate of flow of blood in a shunt (12) according to a process of any one of the preceding claims, comprising:

an indication dilution sensor (50) adapted for monitoring a blood indicator concentration in a circulating line having an inlet side (26) and an outlet side (32),

the inlet side (26) being connected to an inlet (28) for removing blood from a downstream location in the shunt (12),

means for directing blood flowing in the circulating line via the outlet side to an outlet (34) at an upstream location in the shunt (12) to form an admixture with the blood flow in the shunt,

the circulating line having an introduction site (40) for administering an indicator to the blood therein, so as to cause the removed blood admixture to contain the indicator,

a recording means (58) connected to the indicator dilution sensor (50) and adapted to register the indicator concentration monitored by the indicator sensor (50), and

a calculating means responsive to the recording means (58) and adapted to calculate the area under a dilution curve of indicator concentration against time and from this to calculate the rate of blood flow in the shunt (12) according to the equation

$$Q = V/S$$

where:

Q = rate of blood flow in the shunt

V = amount of indicator administered

S = area under the dilution curve."

III. The patent was opposed in its entirety on the grounds (Article 100(a) EPC) that the invention related to a diagnostic and surgical method practised on the human or animal body falling under the exclusion from patentability of Article 52(4) EPC 1973 and lacked an inventive step, having regard to documents:

- D1: N.A. Lassen et al., "*Indicator methods for measurement of organ and tissue blood flow*", in Handbook of Physiology, Chapter 2, Pages 21-63, American Physiological Society, MD, USA, 1983;
- D2: R.A. Hester et al., "*Non-Invasive Determination of Recirculation in the Patient on Dialysis*", ASAIO Journal 1992, Pages M190-M193;
- D3: J. Göthlin et al., "*A Dye-Dilution Method for the Determination of Blood Flow in Cimino-Brescia Arteriovenous Fistulae*", Investigative Urology, Vol 15, No.2, Printed in USA, 1977, Pages 167-168;
- D4: J. Kult et al., "*Das Reale Shuntvolumen Subkutaner Arteriovenöser Fisteln bei Chronisch Hämodialysierten Patienten*", Zeitschrift für kardiologie, Band 62, Heft 2, 1973, Pages 158-164;
- D5: P. Rocha et al., "*Arteriovenous Shunt Measured by Bolus Dye Dilution: Reproducibility and Comparison Between Two Injection Sites*", Catheterization and Cardiovascular Diagnosis, 11: 473-481 (1985).

Further documents were submitted by the patent proprietors (letters of 30 June 2003 and 15 March 2007) in order to show the need and success of the invention:

- D6: J. Sands et al., "*The Effect of Doppler Flow Screening Studies and Elective Revisions on Dialysis Access Failure*", ASAIO Transactions, Printed in USA, Vol. 38, No. 3, Pages M524-M527, July-September 1992;
- D7: H.D. Polaschegg, "*Access Physics*", in Festschrift for Frank Gotch, Volume 12, Supplement 1, May-June 1999, Pages S-33 to S-40;
- D8: Web Pages <http://www.renaltech.com/OurTeam/s33.php3> and <http://www.biolink.com/advisors.html> showing Dr Polaschegg's link to Fresenius;
- D9a: National Kidney Foundation (NKF), Dialysis Outcomes Quality Initiative (DOQI), *Clinical Practice Guidelines 10 to 12 for Vascular Access*, Supplement to American Journal of Kidney Diseases (AJKD), Vol.30, No.4, Suppl.3 (October), 1997, Pages S162-S166;
- D9b: NKF/DOQI, *Clinical Practice Guidelines 10 to 12 for Vascular Access*, Update 2000, AJKD, Vol.37, No.1, Suppl.1 (January), 2001, pages S139-140 and S-150 to S156.
- D10: T.A. Depner, "*Techniques for Prospective Detection of Venous Stenosis*", *Advances in Renal Replacement Therapy*, Volume 2, No.2(July), 1994, pages 119-130;
- D11: List (13 pages) of relevant publications on shunt flow following the publication of the invention;
- D12: Declaration by Dr Spergel of 17 April 2000, with curriculum vitae and exhibits (112 pages);
- D13: P.J. Bosman et al., "*Acces Flow Measurements in Haemodialysis Patients: In Vivo validation of an*

Ultrasound Dilution Technique", J. Am. Soc.
Nephrol., Volume 7, Number 6, 1996, pages 966-969.

With letter of 30 June 2003, the patent proprietors submitted an Auxiliary Request made up of only apparatus claims corresponding to granted Claims 9 to 15. Claim 1 according to that Auxiliary Request read as follows (compared to Claim 9 as granted, additions are indicated in bold, deletions in strike-through):

"1. Apparatus for measuring the rate of flow of blood in a shunt (12) ~~according to a process of any one of the preceding claims~~ comprising:
an indication dilution sensor (50) adapted for monitoring a blood indicator concentration in a circulating line having an inlet side (26) and an outlet side (32)
the inlet side (26) being connected to an inlet (28) for **continuously** removing blood from a downstream location in the shunt (12)
means for directing blood flowing in the circulating line via the outlet side to an outlet (34) at an upstream location in the shunt (12) to form an admixture with the blood flow in the shunt, **and travel downstream in the shunt (12) towards the inlet (28) as an admixture with the blood flow,**
the circulating line having an introduction site (40) for administering an indicator to the blood therein, so as to cause the removed blood admixture to contain the indicator, **as distinguishable blood characteristic at the outlet side (32) of said circulating line,** a recording means (58) connected to the indicator dilution sensor (50) and adapted to register the

indicator concentration monitored by the indicator sensor (50), and a calculating means responsive to the recording means (58) and adapted to calculate the area under a dilution curve of indicator concentration against time and from this to calculate the rate of blood flow in the shunt (12) according to the equation

$$Q = V/S$$

where: Q = rate of blood flow in the shunt
 V = amount of indicator administered
 S = area under the dilution curve."

IV. According to the decision under appeal:

Main Request

- having regard to G 1/04, the process for measuring arterio-venous shunt blood flow during haemodialysis defined in Claim 1 as granted did not relate to a diagnostic method practised on the human or animal body falling under Article 52(4) EPC 1973, because the acquisition of data in form of a dilution curve of an indicator material, as defined in Claim 1, only related to the examination phase of a diagnostic method and Claim 1 lacked any steps of comparison between acquired and standard values;

- however, the process of Claim 1 as granted encompassed substantial physical interventions on the body such as the injection of an indicator material into the blood stream, which entailed a health risk and required professional medical expertise to be carried out, so the process of Claim 1 was to be regarded as a method of treatment of the human or animal body by

surgery under Article 52(4) EPC 1973, even though in the context of the claimed measuring process the physical intervention on the body did not aim in itself at maintaining health but merely constituted a prerequisite for collection of data;

- moreover, having regard to the delivery of a potentially harmful indicator material into the blood of the patient, the process of Claim 1 as granted was excluded from patentability by Article 52(4) EPC 1973, because it encompassed at least one step essential for the desired diagnostic result that did not fall under the exclusive responsibility of the technician skilled in the technology but was to be implemented by medical staff or under responsibility of medical staff, in line with decision T 655/92.

- Consequently, the Main Request was not allowable.

Auxiliary Request

- The Auxiliary Request only contained apparatus claims;

- The apparatus of Claim 1 was not to be objected under Article 52(4) EPC 1973, neither having regard to T 775/97, as its construction was not defined in a way only arrived at in the human or animal body following a surgical method, nor because a diagnostic method was unavoidably implied in the combination of its structural features;

- no formal objections were raised against Claim 1 nor was the novelty of its subject-matter ever objected to;

- as regards inventive step, D2, which not only addressed the problem of reduced blood flow in a shunt but also disclosed an apparatus for measuring access recirculation with most of the structural features as defined in Claim 1 of the Auxiliary Request, was the closest prior art document. However, D2 aimed at measuring access recirculation, which was different from access flow, at least in two aspects: access recirculation occurred during haemodialysis with the lines in normal position (withdrawal being located upstream); and, the measurement of access recirculation was dependent on the pump speed. Thus, the problem to be solved was an improved apparatus for detecting reduced blood flow in a shunt, hence shunt stenosis, in line with the patent in suit. The solution provided by the patent in suit was the provision of means for calculating the dilution area of the indicator and from this the rate of blood flow in the shunt, according to the equation provided in Claim 1. D2 disclosed the features of the preamble of Claim 1 but did not suggest the calculating means of Claim 1, because it focussed on recirculation rather than access flow. Although the measuring technique used in the method defined in Claim 1 was known, e.g. from D1, its application in the context of a shunt where the lines were reversed from normal use was not conventional, nor obvious either.

- So the claimed subject-matter involved an inventive step and the auxiliary request was allowable.

V. In their statement setting out the grounds of appeal, the patent proprietor appellants invoked again their documents D6 to D13 and argued the patentability of the method of Claim 1 as granted.

With letter of 23 April 2008, in response to the statement setting out the grounds of appeal of the opponents, the patent proprietor appellants submitted further documents, as follows:

- D14: D. Scheneditz et al., "*Measurement of Access Flow by Thermodilution: In Vitro Experiments*", JASN 6(3), Sept. 1995, page 502, Abstract;
- D15: M. Germain et al., "*Correlation of Weekly Access Blood rate (Q_a) and Access Stenosis and Clotting: In-Line HCT Technique (ILH)*", JASN 7(9), Sept. 1996, page 1407, Abstract A0808;
- D16: R.M. Lindsay et al., "*The Measurement of haemodialysis Access Blood Flow rates by Hemodynamic Monitor*", JASN 7(9), Sept. 1996, page 1412, Abstract A0830;
- D17: R.M. Lindsay et al., "*A Comparison of Methods for the Measurement of Access Recirculation [AR] and Access Flow [Q_a]*", JASN 7(9), Sept. 1996, page 1412, Abstract A0831;
- D18: J.K. Leypoldt et al., "*Vascular Access Blood Flow rates (Q_a) Measured from Increases (Δ) in Hematocrit (H) when Applying Ultrafiltration (UF)*", JASN 7(9), Sept. 1996, page 1412, Abstract A0828.

VI. In their statement setting out the grounds of appeal, the opponent appellants maintained that the apparatus claims, in view of some features defined therein, still implied surgical measures such as the necessary connection of the apparatus to the shunt, so the apparatus still fell under the exclusion of Article 52(4) EPC 1973. Moreover, the claimed apparatus lacked an inventive step having regard to the combination of D1 and D2, D3 and D2 or D4 and D2.

VII. In a communication in preparation for oral proceedings, the Board drew attention to the issues that needed to be debated and decided (in particular, in relation to exception to patentability, to decisions G 1/07 of 15 February 2010 (OJ EPO 2011, 134), T 1075/06 of 17 May 2011 and T 663/02 of 17 March 2011) and *inter alia* cited US patent 5,312,550 (a patent granted to R.L. Hester, one of the authors of D2, on the method for detecting undesired dialysis recirculation illustrated by D2).

VIII. In response to the communication by the Board:

- (a) the proprietor appellants maintained their Main Request (patent as granted) and enclosed 6 sets of claims as Auxiliary Requests 1 to 6 (letter of 5 September 2011);
- (b) the opponent appellants (letter of 5 September 2011) enclosed a copy of a further document (D19) (HD03/HD03-E Operator Manual, 22 pages, by Transonic Systems Inc.) (i.e. copy of an operator manual of an apparatus as claimed) and maintained that both the process, as defined in Claim 1 as granted or in the auxiliary request, and the apparatus, as defined in Claim 9 as granted or in the auxiliary request, fell under the exception of Article 53(c) EPC (i.e. the exclusion of Article 52(4) EPC 1973). Furthermore, the apparatus of the auxiliary request were also unclear (Article 84 EPC).

IX. Claim 1 of each of Auxiliary Requests 1 to 5 (Auxiliary Request 6 need not be dealt with in this decision, for

the reasons given in Point 24 *infra*) read respectively as follows (compared to Claim 1 as granted, added features are in bold, deleted in strike-through):

Auxiliary Request 1

"1. A process for measuring the rate of blood flow in a shunt (12) in which blood is flowing, comprising:
continuously removing blood from a downstream location in the shunt (12) by way of an inlet (28) to an inlet side (26) of a circulating line;
delivering the removed blood flowing in said circulating line by way of an outlet (34) connected to an outlet side (32) of said circulating line to an upstream location of said shunt (12), so as to cause it to travel downstream in the shunt (12) towards the inlet (28) as an admixture with the blood flow;
changing a selected physical property of the blood in said circulating line to produce a distinguishable blood characteristic at the outlet side (32) of said circulating line;
measuring the amount of change of said distinguishable blood characteristic; and
determining the rate of blood flow in said shunt (12) from the amount of change of said distinguishable blood characteristic by reference to a dilution curve of said amount of change, **wherein the step of changing the selected distinguishable blood characteristic includes changing the sound velocity characteristics of the blood flowing in said circulating line.**"

Auxiliary Request 2

"1. A process for measuring the rate of blood flow in a shunt (12) in which blood is flowing, comprising: continuously removing blood from a downstream location in the shunt (12) by way of an inlet (28) to an inlet side (26) of a circulating line; delivering the removed blood flowing in said circulating line by way of an outlet (34) connected to an outlet side (32) of said circulating line to an upstream location of said shunt (12), so as to cause it to travel downstream in the shunt (12) towards the inlet (28) as an admixture with the blood flow; changing a selected physical property of the blood in said circulating line to produce a distinguishable blood characteristic at the outlet side (32) of said circulating line; measuring the amount of change of said distinguishable blood characteristic; and determining the rate of blood flow in said shunt (12) from the amount of change of said distinguishable blood characteristic by reference to a dilution curve of said amount of change, **wherein the process is not a method for treatment of the human or animal body by surgery.**"

Auxiliary Request 3

Claim 1 according to Auxiliary Request 3 is identical to Claim 1 of the Auxiliary Request underlying the decision under appeal (Point III, *supra*).

Auxiliary request 4

"1. Apparatus for measuring the rate of flow of blood in a shunt (12) ~~according to a process of any one of the preceding claims~~ comprising:

an indication dilution sensor (50) adapted for monitoring a blood indicator concentration in a circulating line having an inlet side (26) and an outlet side (32)

the inlet side (26) being connected to an inlet (28) for **continuously** removing blood from a downstream location in the shunt (12)

means for directing blood flowing in the circulating line via the outlet side to an outlet (34) at an upstream location in the shunt (12) to form an admixture with the blood flow in the shunt, **and travel downstream in the shunt (12) towards the inlet (28) as an admixture with the blood flow,**

the circulating line having an introduction site (40) for administering an indicator to the blood therein, so as to cause the removed blood admixture to contain the indicator, **as distinguishable blood characteristic at the outlet side (32) of said circulating line,**

a recording means (58) connected to the indicator dilution sensor (50) and adapted to register the indicator concentration monitored by the indicator sensor (50), and

a calculating means responsive to the recording means (58) and adapted to calculate the area under a dilution curve of indicator concentration against time and from this to calculate the rate of blood flow in the shunt (12) according to the equation

$$Q = V/S$$

where: Q = rate of blood flow in the shunt
 V = amount of indicator administered
 S = area under the dilution curve

Said apparatus further comprising a blood flow sensor (60) for the measurement of the flow rate (Q_{dial}) of blood in the circulating line, said sensor (60) being connected to the recording means (58),

the calculating means being adapted to calculate the rate of blood flow in the shunt (12) according to the equation

$$Q_{shunt} = V_{ven} / S_{art} - Q_{dial}$$

where; Q_{shunt} = rate of blood flow in the shunt
 V_{ven} = amount of indicator administered
 S_{art} = area under the dilution curve."

Auxiliary Request 5

"1. Apparatus for measuring the rate of flow of blood in a shunt (12) according to

a process for measuring the rate of blood flow in a shunt (12) in which blood is flowing, comprising:

continuously removing blood from a downstream location in the shunt (12) by way of an inlet (28) to an inlet side (26) of a circulating line;

delivering the removed blood flowing in said circulating line by way of an outlet (34) connected to an outlet side (32) of said circulating line to an upstream location of said shunt (12), so as to cause it to travel downstream in the shunt (12) towards the inlet (28) as an admixture with the blood flow;

changing a selected physical property of the blood in said circulating line to produce a distinguishable blood characteristic at the outlet side (32) of said circulating line;

measuring the amount of change of said distinguishable blood characteristic; and

determining the rate of blood flow in said shunt (12) from the amount of change of said distinguishable blood characteristic by reference to a dilution curve of said amount of change

the apparatus comprising:

an indication dilution sensor (50) adapted for monitoring a blood indicator concentration in a circulating line having an inlet side (26) and an outlet side (32),

the inlet side (26) being connected to an inlet (28) for removing blood from a downstream location in the shunt (12),

means for directing blood flowing in the circulating line via the outlet side to an outlet (34) at an upstream location in the shunt (12) to form an admixture with the blood flow in the shunt,

the circulating line having an introduction site (40) for administering an indicator to the blood therein, so as to cause the removed blood admixture to contain the indicator,

a recording means (58) connected to the indicator dilution sensor (50) and adapted to register the indicator concentration monitored by the indicator sensor (50), and

a calculating means responsive to the recording means (58) and adapted to calculate the area under a dilution curve of indicator concentration against time

and from this to calculate the rate of blood flow in the shunt (12) according to the equation

$$Q = V/S$$

where:

Q = rate of blood flow in the shunt

V = amount of indicator administered

S = area under the dilution curve."

X. Oral proceedings were held on 28 September 2011. At the end of the oral proceedings, the decision was announced.

XI. The patent proprietor appellants essentially argued as follows:

Amendments to party's case - New items of evidence and fresh claims requests

(a) D6 to D12 were not new items of evidence, as they were submitted during the opposition proceedings. So they should be considered by the Board.

(b) D14 to D18, submitted in response to the statement setting out the grounds of appeal of the opponents, were post-published but highly relevant items of evidence showing the practical impact that the invention had made in its own field since the priority date of the patent in suit, in line with T 0677/91 of 3 November 1992, thus relevant "secondary indicia" of inventive step. Hence, D14 to D18 should be admitted into the proceedings.

(c) No objections were raised against the admissibility of D19.

- (d) Auxiliary Requests 1, 2 and 4 to 5 were submitted in response to the communication by the Board in preparation for oral proceedings, in particular in order to address the comments by the Board and overcome the objections raised. So they were admissible.

Main Request (Patent as granted)

Exception to patentability

- (e) Claim 1 as granted concerned a process for measuring blood flow. This was the technical reality to be looked at. The technical contribution of the invention did not at all relate to a surgical method. The claimed method did not even recite an interventional or invasive step. In any case, there was no logic to the approach that a single surgical step within a multi-step method prohibited the method from patentability. No one would think that in order to carry out the claimed process a surgical intervention was necessary. As regards the assessment of whether or not the claimed process, having regard to the contested steps of Claim 1 such as "continuously removing blood" and "delivering the removed blood ...", fell under the - narrow - exception of Article 53(c) EPC, the criteria developed in G 1/07, such as invasiveness, health risks and professional expertise, were to be applied.
- (f) As regards invasiveness, the claimed method was carried out after an explicit intervention on the patient's body had been performed, i.e. the initial

setup steps of puncturing the shunt and switching the lines were not part of the claimed measuring process which was carried out when all connections were already in place. In any case, reversal of the needles was not necessary and reversal of the blood lines could actually be carried out by leaving the needles in place in the shunt. Also, the carrying out of the claimed method was entirely non invasive, as was also apparent from the title of D2. The injection as defined in Claim 1 was also not a surgical intervention, as decided in T 663/02.

- (g) As to health risks, these were entirely hypothetical. The claimed method was normally carried out only once a month. After millions of uses, all over the world, no complications had ever arisen. The appellants' argument that no statistics had been presented could be reverted, as the appellants have never brought any evidence of accidents. Since the total volume of blood in all circulating lines was about 250 ml, there was no risk of blood losses, so quite distinctly from T 1075/06 there was no removal of large quantities of blood since the blood was returned to the patient immediately. Furthermore, the injected bolus was merely a saline solution, so no significant depletion of blood components took place. Also, a reversal of the needles was not needed, reversal of the blood lines could be attained by using particular devices located in the lines. So the claimed process did not involve substantial health risks. To the contrary, it had to be regarded as a safe routine technique clearly falling outside of the exception clause.

- (h) As regards the professional expertise required, the context in which the method took place was haemodialysis. However, removal and replacement of needles was not required, not even according to the operating instructions given in D19. Both the setup steps and the claimed method were actually carried out by a nurse or a technician, the attendance of a doctor not being required, at least in the USA. The fact that D19 mentioned "trained medical personnel" did not imply that the method could not be carried out by untrained practitioners. In fact, D19 merely warned to "read the manual prior to use" and "practice carefully". Hence, the personnel would act with the required care upon reading the manual. Also, the mentioning of trained paramedical personnel in D19 did not imply that a physician had to be involved. This was particularly true when the patient himself carried out the claimed measuring process, or even the whole haemodialysis treatment. Home haemodialysis was a reality in the world. The argument that delegating to nurses and technicians was not relevant was not convincing, as according to T 663/02 the delegation was an indication of whether or not the intervention was substantial and dangerous, and for unsubstantial and non-dangerous interventions the trend was to, as far as possible, rely upon low cost, i.e. less trained personnel.
- (i) Therefore, the process of Claim 1 as granted did not fall under the exception clause of Article 53(c) EPC.

Auxiliary Request 1

- (j) Claim 1 of Auxiliary Request 1 set out more explicitly than what was already clear from the patent in suit that the claimed subject-matter did not seek to protect methods for treatment of the human or animal body by surgery, in particular those involving delivery of isotopes to the blood.

Auxiliary Request 2

- (k) Claim 1 of Auxiliary Request 2 included a disclaimer to exclude protection in respect of methods for treatment of the human or animal body by surgery from the protection sought. In particular, the disclaimer aimed at limiting the process of Claim 1 to non-invasive operations, i.e. to address the problem that e.g. circulation of a large quantity of blood could be regarded as an invasive intervention. The patent proprietors were aware that a disclaimer per se was problematic with respect to clarity. Therefore they had formulated the disclaimer as close as possible to the clear wording used by the EPC in Article 53(c) EPC.

Auxiliary Request 3

- (l) Claim 1 of Auxiliary Request 3 was identical to Claim 1 of the Auxiliary request underlying the decision under appeal, which had been found to be in compliance with the EPC. The amendment to Claim 1 arose from the necessity, after deletion of Claim 1 as granted, of removing the explicit reference to the process while keeping the

apparatus claim as close as possible to granted Claim 9, hence, to meet the requirement of conciseness. So Auxiliary Request 3 was clearly formally allowable.

- (m) From Article 52(4) EPC 1973 it was furthermore clear that the exclusion from patentability did not apply to products, these including apparatus. The facts of case T 775/97 were rather different from the one at issue.

Auxiliary Requests 4

- (n) Claim 1 of Auxiliary Request 4 was identical to Claims 1 and 2 of Auxiliary Request 3, i.e. it was a fall back position, if Auxiliary Request 3 was not allowed under Article 56 EPC.

Auxiliary Request 5

Amendments

- (o) Auxiliary Request 5 consisted of the subject-matter of apparatus claims 9 to 15 as granted. Claim 1 was identical to Claim 9 as granted but with full recitation of the process of Claim 1 as granted, to replace the reference to the process of Claim 1 as granted present in Claim 9 as granted. This full recitation was necessary to cope with the deletion of Claim 1 as granted. Since Auxiliary Request 5 addressed the comments made in the Board's communication, it was clearly formally allowable.

Closest prior art

- (p) According to the established case law of the boards of appeal, the closest prior art document should be one concerning the same technical field of the invention and possibly addressing the same technical problem. The patent in suit addressed the measurement of the blood flow in a shunt.
- (q) D1 did not mention shunt flow determination. D2, invoked by the opponents, did not address shunt but recirculation flow. Recirculation flow was only present when a dialysis machine was connected, and actually depended on the pump flow, whereas shunt flow was always present. Therefore, the choice of D2 was complete hindsight, so D2 could not be the closest prior art document for assessing inventive step. Indeed, the idea of starting from D2, i.e. from an unrealistic point, was already an indication of non obviousness.
- (r) D3, D4 and D5 all concerned the determination of blood flow in fistulae, i.e. the measure of shunt flow as does the patent in suit, and had nothing to do with recirculation. Among them, D5, which was concerned with flow rates, was the closest prior art. Nevertheless, the method of D5 still required three punctures.

Problem and solution

- (s) The technical problem over D5, thus also over D3 and D4, was to provide a less invasive but more accurate method for measuring the shunt flow.

- (t) The claimed solution to this problem was distinct from the known solutions of D3, D4 and D5 in that *inter alia* the inlet and outlet of the circulating line were provided both in the shunt, the inlet was provided downstream in the shunt, a physical property was changed in the circulating line, because an inlet port was provided in the circulating line, calculating means were provided.

Non obviousness

- (u) D2 was not concerned with blood flow in shunts. The key teaching of D2, as illustrated by Figures 1 and 2, was such that the outlet of the line was downstream in the shunt, without recognition of measuring shunt flow, in any orientation of inlet and outlet. In fact, Figure 2 of D2 was not about measuring anything. The formula for determining the shunt flow ($Q=V/S$) mentioned in present Claim 1 made sense only if the circulating lines were OK. So, any references to D2 were pure hindsight. Since D2 was not the proper starting point, the reference to the published international PCT application of the patent in suit was not at all relevant.
- (v) Also the other documents showed outlet oriented in the opposite direction, compared to the orientation mentioned in Claim 1. Hence, by starting from these documents, e.g. D5, invasiveness could be reduced only by a process having inlet and outlet still in an opposite orientation, compared to the claimed solution. In particular, D5 and D2 were not

interchangeable nor would they be combined without hindsight.

- (w) So, the claimed apparatus was not obvious.
- (x) This conclusion was confirmed by a number of secondary indicia as mentioned in D7 and D9 to D13.

XII. The opponent appellants essentially argued as follows:

Amendments to party's case - New items of evidence and fresh claims requests

- (a) No objections were raised against the admissibility of documents D6 to D13.
- (b) Instead, documents D14 to D18 had been filed late, although being old (i.e. they could have been filed well before, since lack of an inventive step had been objected to already during the opposition proceedings) and were not relevant, as they could not support inventive step. So D14 to D18 should not be admitted into the proceedings.
- (c) D19 was an operator manual of the claimed apparatus of the patent proprietors, which *inter alia* mentioned the patent in suit (EP-B-0 781 161) on its very first page. D19 illustrated the functioning of the apparatus and was a highly relevant item of evidence to be admitted into the proceedings.

- (d) The claims of the auxiliary requests were unclear, in particular because the apparatus claims included process features.

Main Request (Claims as granted)

Exception to patentability

- (e) Claim 1 *inter alia* defined the steps "continuously removing blood ..." and "delivering the removed blood ...". According to the patent specification, these steps encompassed blood removal from, circulation and return delivery to patients' body, during haemodialysis, i.e. while the patients were connected to a dialyser. This was also apparent from D19, which mentioned that the process was for use only during haemodialysis. Hence, Claim 1 was directed to a process practised on the human or animal body.
- (f) The claimed process was actually carried out during haemodialysis, which was normally performed in clinical environments, under supervision and responsibility of medical personnel. Home haemodialysis was an exception rather than a reality. Thus, the steps of Claim 1 could not routinely be carried out by any person. At least in Europe, only trained medical personnel should monitor and carry out the method. As regards the delegation to nurses or technical personnel, this was not decisive as established in G 1/04 (OJ EPO 2006, 334), and confirmed in G 1/07, as it could change from place to place. Moreover, the claimed measurement process required an interruption of the

dialysis treatment and a proper setting of the blood flow rate. This could only be done by the treating physician.

- (g) According to D19, the flow rate of the circulating blood was about 250-300 ml/min. As admitted by the patent proprietors in the written proceedings, about 10 minutes were necessary for carrying out the measurement. So about 3 litres of blood were circulating, which was a large part of the total human blood volume. This large part of the human blood went into contact with large foreign surfaces, which also impacted on its clotting system, so requiring that anticoagulants be injected. In T 1075/06 (Point 2.1.1.2 of the Reasons), it was held that the removal of large quantities of blood from the patient's body was a "substantial physical intervention which required professional medical expertise to be carried out", and resulted in "substantial health risks even when carried out with the required professional care and expertise". It was also apparent from D19 that the claimed process should be carried out only on haemodialysis patients under stable cardiovascular condition. Thus, the claimed process, comprising steps such as blood removal from and return to patients' body, whereby the patients suffered at least from disrupted or reduced kidney function, definitely implied serious health risks. Further risks were related to the fact that if an appropriate reversal of the arterial and venous lines back to normal did not take place after the performance of the measurement, only a part of the blood would be cleaned during haemodialysis. Hence, the claimed

process was a substantial physical intervention accompanied by substantial health risks even when carried out by trained medical personnel.

- (h) The patent proprietors' argument that the process had been carried out millions of times without problems was not convincing, as surgical interventions remained such even when no problems arose. The argument that reversal of needles was not necessary was also not convincing, as this was required in the patent in suit itself. Also, Claim 1 was open as regards blood flow rates, injection substances and rates, replacement of needles, etc., hence very broad.
- (i) As regards decision T 663/02, it concerned a different situation, the injection of a standard contrast agent, which was regarded as a routine operation, carried out without substantial health risks. Instead, the change of a blood characteristic with possibly harmful agents as defined in Claim 1 was not without risks.
- (j) So the claimed process was not patentable for being a method for treatment of the human or animal body by surgery (Article 53(c) EPC).

Auxiliary Request 1

- (k) The process of Claim 1 of Auxiliary Request 1 still comprised the contested steps of blood removal from and return to the human or animal body. So, for the very same reasons as given for the Main Request, it was not allowable (Article 53(c) EPC).

Auxiliary Request 2

- (1) The disclaimer introduced in Claim 1 of Auxiliary Request 2 rendered the claimed subject-matter unclear. In particular, since at least two steps constituted surgical interventions practised on the human or animal body, it was not clear what remained of them, why and how they should no longer be surgical. Hence, neither the skilled person nor the public could determine what non-surgical process, if any, was to be protected, nor gather how the process steps should be carried out. So, Claim 1 lacked clarity. Such a disclaimer also contravened the requirements of Article 123(2) EPC. Auxiliary Request 2 was thus not allowable.

Auxiliary Request 3

- (m) Claim 1 of Auxiliary Request 3 now concerned an apparatus. However, the inclusion of some of the deleted process features of Claim 1 as granted such as "continuously", "travel downstream" and "distinguishable blood characteristic" rendered the claimed subject-matter unclear. In particular, it was not clear whether the term "continuously" had the same meaning as in Claim 1 as granted, hence whether an apparatus with the same structural features but for a non-continuous removal of blood also fell under Claim 1. Also, whether the mentioned "distinguishable blood characteristic" meant the indicator concentration. Thus, Claim 1 of Auxiliary Request 3 did not comply with Article 84 EPC.

- (n) Also the apparatus claims fell under the exclusion clause of Article 53(c) EPC if the criteria developed in T 775/97 were taken into consideration. Without a surgical intervention, the apparatus could not be connected to the patient in order to carry out the measuring process. The operation of the claimed apparatus required several surgical steps as already explained with regard to the process claims.

Auxiliary Request 4

- (o) Since Claim 1 of Auxiliary request 4 contained the objected to process terms "continuously", "travel downstream" and "distinguishable blood characteristic", the objections of lack of clarity raised against Claim 1 of Auxiliary Request 3 applied to Claim 1 of Auxiliary Request 4 as well.

Auxiliary Request 5

- (p) The amendments to the claims of Auxiliary Request 5 were not contested.
- (q) As regards the objections under Article 53(c) EPC raised against apparatus Claim 1, reference was made to the written arguments on file.
- (r) As to inventive step, D3, D4 and D5 all concerned the same method as the patent in suit. Also D2, acknowledged in the patent in suit, albeit concerning a non-invasive process for measuring recirculation, could be considered as a starting

point, especially if account were taken to the international application on which the patent in suit was granted, which mentioned also the measure of "undesirable recirculation during haemodialysis". The closest prior art documents thus were D2 or D4 and D5.

- (s) Starting from D2 as the closest prior art, all structural features were already disclosed, including reversal of the circulating lines. Only the particular calculating means were not disclosed.
- (t) The problems addressed by the patent in suit were mentioned in its Paragraphs [0004] and [0007].
- (u) Over D2, the problem to be solved was the alternative possibility of using the apparatus of D2 for measuring the shunt flow, i.e. to adapt the method of D2 to the measure of access flow.
- (v) Since D3, D4 and D5 disclosed the measure of the shunt flow, and since no structural modifications of the apparatus of D2 were necessary, apart from reversal of the lines, a possibility mentioned in D2, the combination of D2 with any of D3, D4 and D5, led obviously to the claimed apparatus.
- (w) Starting from D5 as the closest prior art, in particular from Figure 2 thereof, which showed injection of the dye at an upstream location in the shunt and a measurement of access flow carried out downstream, the only distinguishing feature of the claimed process was the injection port in the circulating line. The problem solved over D5 thus

was to provide a less invasive process. The way of avoiding the injection in the upstream location in the shunt was shown by D2, which disclosed a non-invasive method comprising injection of the bolus not in the artery or vein but in the conduits of the circulating line.

XIII. The appellant proprietors requested that the decision under appeal be set aside and the patent be maintained as granted (Main Request) or on the basis of Auxiliary Requests 1 to 6 filed with letter of 5 September 2011.

XIV. The appellant opponents requested that the decision under appeal be set aside and the patent be revoked.

Reasons for the Decision

1. The appeals are admissible.

Amendments to parties' cases

New items of evidence

2. The decision under appeal mentions documents D1 to D5.

2.1 D6 to D12 and D13 were presented to the Opposition Division before the oral proceedings took place but the decision under appeal did not mention them. However, this cannot be taken as an implicit decision not to admit D6 to D13 into the opposition proceedings. Since the proprietor appellants have again invoked D6 to D13 in their statement setting out the grounds of appeal,

- they are admitted in the appeal proceedings for consideration.
- 2.2 D14 to D18 were submitted by the proprietor appellants with their response to the statement setting out the grounds of appeal of the opponents. They concern post-published evidence on the impact of the claimed invention, i.e. secondary indicia of non obviousness, to counter the arguments of the opponent appellants. The Board sees no reason for not allowing them into the proceedings.
- 2.3 D19 is the latest evidence submitted by the opponent appellants just before the oral proceedings. It is an operating manual of the apparatus underlying the patent in suit, which did not surprise the proprietor appellants. In fact, D19 has indisputably been acknowledged as a relevant item of evidence by all the parties and was extensively debated during the oral proceedings before the Board.
- 2.4 Consequently, all of D6 to D19 are admitted into the appeal proceedings for consideration.

New claims requests

3. The Main Request and Auxiliary Request 3 underlie the decision under appeal, so their admissibility is not an issue of the present appeal.
- 3.1 The further fresh claim requests (Auxiliary Requests 1, 2, 4 and 5) were filed to address the Board's comments in the communication in preparation for oral proceedings and did not raise unexpected issues which

the Board and the opponent appellants could not be expected to deal with, without delay or adjournment of the oral proceedings.

3.2 Thus, all the claims requests are considered.

Main Request

Exception to patentability of methods for treatment of the human or animal body by surgery

Applicable provisions

4. According to Article 1 of the decision of the Administrative Council of 28 June 2001 on the transitional provisions under Article 7 of the Act revising the European Patent Convention of 29 November 2000, Article 53 EPC shall apply to European patents already granted at the time of entry into force of the revision (13 December 2007), hence to the present patent in suit.

The process of Claim 1

5. Claim 1 is directed to a process for measuring the rate of blood flow in a shunt in which blood is flowing. It comprises the steps of "continuously removing blood from a downstream location in the shunt (12) ..." and "delivering the removed blood flowing in said circulating line by way of an outlet (34) connected to an outlet side (32) of said circulating line to an upstream location of said shunt (12), ...".

- 5.1 According to the very first paragraph of the patent in suit, the process of Claim 1 is for measuring arterio-venous shunt blood flow during haemodialysis. Still according to the patent in suit (Paragraph [0002]), haemodialysis is a process by which an artificial kidney replaces the function of a patient's kidney. The majority of patients have an arterio-venous shunt implanted in a location having a high blood flow, to simplify the withdrawal of blood from a location close to the arterial side of the shunt and the return of the purified blood downstream of the withdrawal site, i.e. closer to the venous side of the shunt. The implanted shunt can be a native or artificial vessel that has been established surgically between a patient's artery and vein.
- 5.2 Since Claim 1 as granted is thus directed to a process that is carried out *in vivo* on a human or animal body, from which blood is removed and reintroduced, it has to be decided whether the claimed process is a method for treatment of the human or animal body by surgery falling under the exception clause of Article 53(c) EPC.
- 5.3 In this regard, the criteria developed in decision G 1/07 (OJ EPO 2011, 134) of the Enlarged Board of Appeal have to be taken into consideration.

The criteria developed in G 1/07

6. Before dealing with the criteria of G 1/07 in detail, it is necessary to deal with the proprietor appellants' assertion that exclusions from patentability should be construed narrowly.

- 6.1 According to G 1/07 (Reasons, Point 3.1), a provision containing exclusions or exceptions from patentability is to be interpreted in such a manner that it takes its effect fully and achieves the purpose for which it was designed.
- 6.2 As further explained in G 1/07 (Reasons, Points 3.4.2.1 to 3.4.2.3), the broad construction of the term "treatment by surgery" as previously developed in T 182/90 (OJ EPO 1994, 641) and T 35/99 (OJ EPO 2000, 447) was no longer justified. Also, the definition given in opinion G 1/04 (OJ EPO 2006, 334) (Reasons, Point 6.2.1) that "any physical intervention on the human or animal body ..." is a method of surgery within the meaning of Article 52(4) EPC 1973 appeared too broad.
- 6.3 A "narrower understanding" of what constitutes by its nature a "treatment by surgery" within the meaning of Article 53(c) EPC was hence required. It was generally stated (Reasons, Point 3.4.2.2) that *"such a narrower understanding rules out from the scope of the application of the exclusion clause uncritical methods involving only a **minor intervention** and **no substantial health risks**, when carried out with the required care and skill, while still adequately protecting the medical profession" [emphasis added]*. In particular it was found that it *"appeared hardly still justified to exclude from patentability certain, albeit invasive techniques, at least when performed on **uncritical parts of the body**", which were carried out in a **non-medical, commercial environment** like in cosmetic salons and in beauty parlours" [emphasis added]*. This was said to apply *"as a rule to treatments such as tattooing,*

*piercing, hair removal by optical radiation, micro abrasion of the skin". On the other hand, it was required that the "definition of the term "treatment by surgery" must cover the kind of interventions which represent the core of the medical profession's activities, i.e. the kind of interventions for which their members are specifically trained and for which they assume a particular responsibility". These physical interventions on the body were defined as those which "require **professional medical skills** to be carried out and which involve health risks even when carried out with the required medical professional care and expertise" [emphasis added].*

6.4 Therefore, G 1/07 (Reasons, Point 3.4.2.4) indicates a new direction in which further practice and jurisprudence should develop, namely that the exclusion from patentability should apply only to methods in respect of which it is justified on grounds of public health, the protection of patients and the freedom of the medical profession to apply the treatment of choice to its patients.

6.5 In the present case it now has to be decided whether the process of Claim 1 as granted belongs to the kind of methods which should not be covered by the exception clause according to this "narrower understanding" of the Enlarged Board of Appeal and according to the criteria developed in G 1/07. According to G 1/07 (Reasons, Point 3.4.2.6), this assessment has to be done on a case-by-case basis, with each category of cases being assessed on its own merits.

7. The main criteria developed in G 1/07 concern the criticality of the parts of the body affected by the method, the degree of intervention, the environment in which the method is carried out, the required medical expertise, if any, and the health risks incurred (as highlighted in Point 6.3, *supra*). These points will be considered in the following sections.

Criticality of the parts of the body affected by the method

8. The claimed process involves the continuous removal of blood from a shunt, its subsequent flowing through a circulating line of an extracorporeal circuit and the re-delivery of the blood to the shunt, where it forms an admixture with the blood flowing in the shunt.
 - 8.1 In a medical sense, blood is a (flowing) organ of the human body, performing numerous functions which are essential to the health of the patient (T 1075/06, Reasons, Point 2.1.1.2). Accordingly, it can hardly be regarded as an "uncritical part of the body".
 - 8.2 As regards the arterio-venous shunt, it can be created by joining an artery and a vein together through anastomosis, to bypass the capillaries, whereby a high blood flow is created in the shunt. Alternatively, an artificial vessel can be used to join artery and vein. The shunt is usually created in the lower arm but may also be situated on the hand. In any case, at least when the shunt is created by anastomosis to ensure the required access to the blood, in order to carry out haemodialysis, the shunt too cannot be regarded as an "uncritical part of the body".

8.3 Therefore, the claimed process is practised on body parts (blood and shunt) that are not uncritical for the health of the patient, whereby at least one of them (blood) is manipulated during the process. As mentioned in G 1/07 (Reasons, Point 3.4.2.5), "manipulating a body part is traditionally considered surgical". The Board considers that this traditional approach still applies to "*in vivo*" blood manipulation, blood not being an uncritical organ of the body.

8.4 Hence, the claimed method surgically affects a not uncritical part of the body.

Degree of intervention on the human or animal body

9. The specification of the patent in suit neither discloses a specific amount of the blood flow rate in the circulation line, nor the duration of the process. According to D19 (top of page 16), a typical flow value is 300 ml/min. Taking into account a duration of about 10 min, acknowledged as typical by the proprietor appellants in their letter of 5 September 2011 (Point 5.3, third paragraph, first sentence), the total quantity of blood flowing through the circulation line of the extracorporeal circuit during the measurement would be about 3 litres, i.e. more than one half of the average total blood volume of an adult patient. Even if the duration of the measurement were to be shorter, a substantial volume of blood is nevertheless being circulated during the measurement.

9.1 Since the process of Claim 1 as granted involves a continuous manipulation of a large part of the flowing organ blood in an extracorporeal circuit connected to

the patient, it is far from being a "minor intervention". The claimed process therefore involves a significant degree of intervention on the body.

The environment (medical, non-medical, commercial) in which the method is carried out

10. That the process of Claim 1 as granted is performed "during haemodialysis" is not only disclosed in paragraph [0001] of the patent in suit but also indicated in D19 (top of page 3). As a rule, haemodialysis is carried out in a medical environment, i.e. hospital, clinic or dialysis centre. The fact that, in some countries, nowadays, haemodialysis may also be carried out at home represents the exception rather than the rule, an exception which is only available under very specific conditions for certain kinds of patients, who nevertheless require detailed instructions and temporary assistance of medically trained personnel.

10.1 Although, as ruled in opinion G 1/04 (Reasons, Point 6.3, to be dealt with in more detail below), the fact that the method steps can also be practised by the patient himself or herself is not a decisive criterion with respect to the applicability of the exception clause, the conditions under which the claimed method is carried out are nevertheless not comparable to a "commercial environment like cosmetic salons and in beauty parlours", where certain kinds of treatment may not be excepted from patentability.

10.2 In the Board's view, the process of Claim 1 as granted is performed in an *essentially clinical* environment, i.e. in a medical environment.

Required professional medical expertise

11. Claim 1 itself does not address haemodialysis, but as indicated above its process is carried out during haemodialysis.

11.1 Haemodialysis is usually prescribed and supervised by nephrologists, as a consequence of a serious kidney dysfunction, i.e. of the inability of the kidneys to ensure the cleaning of the blood and the water balance in the body, resulting in accumulation of water and dangerous substances in the body, eventually leading to dysfunctions in almost all of the organs of the body. The treatment is initiated and managed by specialised medical staff specifically trained in extracorporeal blood treatment techniques, according to the detailed instructions of the physician and under his or her control and responsibility.

11.2 In order to perform the claimed measurement process, the dialysis treatment has to be interrupted, the direction of flow in the shunt is to be reversed and the rate should be set at a specific value (e.g. 250 to 300 ml/min, see D19, top of page 16). In the Board's view, these steps in particular require a dedicated decision of the responsible physician. This becomes also evident from the fact that D19 (page 3) restricts the use of the claimed measurement process to "patients under stable cardiovascular condition" and specifically

- excludes "unattended monitoring of conditions which could result in imminent danger to the patient".
- 11.3 Therefore, the claimed *in vivo* process requires "professional medical expertise".
- 11.4 Referring to G 1/07 and T 663/02, the patent proprietor appellants argued that "professional medical expertise can only be considered to be the expertise of a doctor or "physician"", which was to be distinguished from the care and skill of a "duly trained and qualified nurse or paramedical professional" to whom a physician may delegate minor routine interventions not implying a substantial health risk for the patient. Since the claimed method was routinely carried out by a nurse or dialysis technician, i.e. paramedical personnel, it represented a delegated act which could not be considered as belonging to the "core of medical activities" and should thus not fall under the exception clause.
- 11.5 The Board cannot follow this approach for the following reasons. It is true that G 1/07 (Reasons, Point 3.4.2.3) states that "any definition of the term treatment by surgery must cover the kind of interventions which represent the core of the medical profession's activities". This positively formulated requirement, however, does not imply that interventions which do not represent the core of the medical profession's activities do not generally fall under the exception.
- 11.6 Moreover, G 1/07 uses the definition of "the core of the medical profession's activities, i.e. the kind of interventions for which its members are specifically

trained and for which they assume a particular responsibility". The term "medical profession" cannot be regarded as being restricted to medical doctors and physicians, i.e. academically trained personnel. It appears that the broad term "medical profession" was chosen to cover all health care providers who professionally practise medical acts, thus also physicians under training, nurses and other paramedical professionals, who are undoubtedly "specifically trained" and assume "a particular responsibility" for the interventions they perform. Any other interpretation would run against the purpose of the exception provision which is, as set out by the Enlarged Board of Appeal, to free the medical profession from constraints which would be imposed on them by patents granted on methods for surgical treatments, because also paramedical staff act in the interest of public health and patients.

- 11.7 This understanding is consistent with the choice of the similarly broad term "medical or veterinary practitioner" used in Opinion G 1/04 (OJ EPO 2006, 334) with respect to diagnostic methods, which was explicitly distinguished from the more specific term "physician" (Reasons, Point 2). In point 6.3 of the Reasons of this Opinion, it is clearly stated that *"whether or not a method is a diagnostic method within the meaning of Article 52(4) EPC [1973] should neither depend on the participation of a medical or veterinary practitioner, by being present or by bearing the responsibility, nor on the fact that all method steps can also, or only, be practised by medicinal or non-medicinal support staff, the patient himself or herself or an automated system"*.

11.8 Accordingly, no distinction is to be made between a delegating physician and paramedical (or even non-medical) support staff with respect to the performance of diagnostic methods, and it cannot be derived from G 1/07 that such a distinction should apply for surgical methods. On the contrary, the approach taken in G 1/04 is explicitly confirmed by G 1/07 (Reasons, Point 3.4.1) as follows: "Whether or not a method is excluded from patentability under Article 53(c) EPC cannot depend on the person carrying it out. The findings of the Enlarged Board in point 6.3 of the Reasons of G 1/04 relate to diagnostic methods, but they quite generally deal with the exclusion from patentability under Article 52(4) EPC 1973 and are thus equally valid with respect to the other exception conditions contained in Article 53(c) EPC".

11.9 Therefore, the present Board does not follow the approach ("paramedical profession") suggested in Point 3.2.4 of the Reasons of T 663/02.

Health risks

12. In the extracorporeal circuit, the blood is subjected to conditions of a non-natural environment quite different from the vasculature within the patient's body. In order to avoid deleterious effects on the blood in the extracorporeal circuit and resulting negative side effects on the patient upon its re-delivery, a number of measures and precautions must be taken. In particular, sterility must be maintained in order to avoid infections, and the temperature and the blood flow rate be properly controlled. Bubble traps

are usually installed within the circuit in order to exclude the presence of air in the re-delivered blood which could lead to embolisms. Moreover, leakages resulting in blood losses have to be avoided. Blood clotting due to shear stresses and contact with artificial surfaces represents a serious risk since it may lead to thrombosis. This usually requires the addition of an anticoagulant, i.e. a medicament. Further problems and health risks might arise from the fact that the shunt, where flow is to be measured, can already be partially stenosed and that the inverted flow of blood therein causes blood clots to be dislodged into the patient's circulatory system. All these conditions must be continuously monitored and carefully controlled, and in cases of deviations and problems, immediate action must be taken to prevent danger for the patient (who is normally already in an impaired health state due to chronic renal failure, thus particularly sensitive to treatment). This requires the attendance of specially qualified and medically trained personnel, and, as a rule, the presence of a physician who at least supervises the procedure. Moreover, the necessary emergency equipment and personnel must be available. Most of the above-mentioned aspects also become directly evident from page 3 of D19. It is therefore clear that the patient is subjected to a number of health risks, even when the process is carried out with the required medical professional care and expertise. Some of these risks are certainly "substantial", even though the likelihood of their occurrence may be rare.

- 12.1 The proprietor appellants' argument that they were not aware of any complications or health risks, these only

being hypothetical and not based on any evidence or reports, is not convincing.

12.2 In the Board's view, the wording "entails" or "involves a substantial health risk" used in G 1/07 cannot be understood as requiring a factual risk analysis based on objective evidence for the following reasons.

12.2.1 Firstly, any risk is "hypothetical" by its very nature. In principle, it may be possible to quantify the likelihood of occurrence of a certain risk in absolute terms, taking into account statistical data. However, in many situations, significant and reliable data are not available. This applies in particular to the evaluation of health risks for patients undergoing a medical treatment. Since the treatment is generally adapted to the individual patient, comparable and thus reliable data are difficult to obtain. For new kinds of treatment, such as are frequently the subject of patent applications, e.g. the reversal of blood flow in a shunt in the present case, such data as a rule do not yet exist at all.

12.2.2 Moreover, what would seem relevant is not a risk analysis on an absolute scale, but a relative evaluation of the health risks for the patient. This implies a consideration of the physical state of the individual patient and a judgement of the health risks in relation to the potential benefit to be achieved by the intervention. This judgement or balance itself would require "professional medical expertise" and belongs to the "core of the medical profession's activities".

12.2.3 For the above reasons, the Board is of the opinion that an objective and concrete analysis of the absolute or relative risks, which is hardly feasible, cannot have been intended by the Enlarged Board of Appeal and should therefore not be required. Accordingly, the present Board has not followed the approach ("risk matrix") suggested in Point 3.2.5 of the Reasons of T 663/02.

12.2.4 The assessment of the "risk-criterion" is therefore limited to a more abstract basis, i.e. to the questions "Is a certain health risk present?" and "Is it substantial?". A health risk is considered to qualify as "substantial" whenever it goes beyond the side effects associated with the treatments mentioned in G 1/07 (piercing, tattooing, etc.) which are generally limited to harmless infections of superficial tissues due to non-sterile working conditions.

12.2.5 In contrast thereto, the above-mentioned health risks of the claimed method, which are objectively present, are undoubtedly "substantial".

Conclusion

13. It follows from the above that the claimed process does not fall under the "narrower understanding", i.e. does not belong to the kind of methods which should not be covered by the exception clause according to the criteria developed in G 1/07.

13.1 Claim 1 comprises the steps of "continuously removing blood from a downstream location in the shunt (12) ..." and "delivering the removed blood flowing in said

- circulating line by way of an outlet (34) connected to an outlet side (32) of said circulating line to an upstream location of said shunt (12), ...".
- 13.2 It has been established that these steps are invasive and represent a substantial physical intervention on the body which requires professional medical expertise to be carried out and which entails a substantial health risk even when carried out with the required professional care and expertise (Headnote 1 of G 1/07 and last paragraph of Point 3.4.2.7 of the Reasons).
- 13.3 According to the established jurisprudence of the Boards of Appeal, a multi-step method falls under the exception clause of Article 53(c) EPC, if it includes at least one feature that constitutes a method step for the treatment of the human body by surgery (G 1/04, Reasons, Point 6.2.1; G 1/07, Reasons, Point 3.2.5).
- 13.4 The possible technical contribution of the invention as mentioned by the proprietor appellants is not a criterion to be taken into consideration in this context.
- 13.5 The present case is quite different from that underlying T 329/94 (OJ EPO 1998, 241), referred to by the proprietor appellants, which related to a blood extraction assistance method for facilitating sustained venous blood flow through a human limb towards a venous blood extraction point. In that case the blood extraction itself did not form part of the claimed subject-matter. If that had been the case, it was stated that withdrawal of blood would have fallen under the exclusion clause of Article 52(4) EPC 1973 three

times, namely as treatment by therapy and surgery and as a diagnostic method (point 4 of the Reasons). With respect to the last two aspects it must be noted, however, that decision G 1/07 and opinion G 1/04 have subsequently been issued by the Enlarged Board of Appeal and the criteria developed therein must now be taken into consideration.

- 13.6 Therefore, Claims 1 to 8 of the Main Request are directed to a method for treatment of the human body by surgery which is excepted from patentability under Article 53(c) EPC.

Further steps of the process of Claim 1 as granted

14. Having regard to the above conclusion on Claims 1 to 8 of the Main Request under Article 53(c) EPC, the Board need not decide whether the step of "changing a selected physical property of the blood in said circulating line to produce a distinguishable blood characteristic at the outlet side (32) of said circulating line" in claim 1 constitutes a method step for the treatment of the human body by surgery or therapy, or whether the necessary reversal of the blood line connection from normal (see column 2, paragraph [0009] of the patent in suit) implies or encompasses a removal and re-insertion of the needles into the shunt which could also constitute a surgical treatment. Similarly, the question whether the claimed method is a diagnostic method can be left unanswered.

Auxiliary Request 1

15. Claim 1 of Auxiliary Request 1 still comprises the steps of "continuously removing blood from a downstream location in the shunt (12) ..." and "delivering the removed blood flowing in said circulating line by way of an outlet (34) connected to an outlet side (32) of said circulating line to an upstream location of said shunt (12), ...", which are surgical (Points 8.4, 9.1, 11.3, 12.2.5 and 13.6 *supra*).

15.1 Claims 1 to 7 of Auxiliary Request 1 are thus directed to a method for treatment of the human body by surgery, which is excepted from patentability under Article 53(c) EPC for the same reasons as for the Main Request.

15.2 The further limitation introduced, taken from Claim 7 as granted, with regard to the step of "changing a selected physical property of the blood ..." does not change this conclusion.

Auxiliary request 2

Admissibility of disclaimer excluding subject-matter not eligible for patent protection

16. Claim 1 of Auxiliary Request 2 includes (at the end its definition) the feature "wherein the process is not a method for treatment of the human or animal body by surgery", i.e. a disclaimer.

16.1 Reference was made in this respect to G 1/03 and G 2/03 (OJ EPO 2004, 413 and 448), according to which an undisclosed disclaimer may be allowable in order to

disclaim subject-matter which, under Articles 52 to 57 EPC, is excluded or exempted from patentability for non-technical reasons (see point 2.1 of the Headnote and point 2.4 of the Reasons). However, in the third paragraph of point 3 of the Reasons of G 1/03, it is emphasized that the requirements of Article 84 EPC are also applicable to claims containing disclaimers. The requirement of clarity (Article 84 EPC) is not met in the case at issue for the following reasons.

- 16.2 It has already been established that the steps of "continuously removing blood from a downstream location in the shunt (12) ..." and "delivering the removed blood flowing in said circulating line by way of an outlet (34) connected to an outlet side (32) of said circulating line to an upstream location of said shunt (12), ..." constitute method steps for the treatment of the human body by surgery. Claim 1 of Auxiliary Request 2 still includes these steps.
- 16.3 A mere renaming of the thus excepted method of surgical treatment by means of the formula "the process is not a method for treatment of the human or animal body by surgery" cannot overcome the objection, and indeed renders the claim unclear, if not contradictory in itself (T 67/02, Reasons, Point 2.1).
- 16.4 A clear delimitation and distinction between excepted surgical applications and possibly allowable non-surgical applications of the claimed process requires that the two methods be distinct, i.e. separable, which means that they must be of a different nature and may be carried out in different ways. As a case in point, reference may be made to D2, which discloses both "in

vitro" and "*in vivo*" methods. Such a distinction has not been made in the present case. In the present case, it cannot be seen how the claimed process would work without the surgical steps of removing from and redelivering the blood to the shunt.

16.5 Indeed, the proprietor appellants' argument has been that Claim 1 of the Main Request covered the (in their view arguably excepted) processing of large volumes of blood and the disclaimer of Auxiliary Request 2 served to limit the claim to (in their view clearly non-excepted) small volumes.

16.6 This argument is not convincing, in particular because the resulting volume is not quantifiable and remains ill-defined. Also, as shown above, this aspect only plays a role with respect to one among several criteria taken into consideration when assessing the applicability of the exception clause.

16.7 Thus, the subject-matter to be protected by the process claims of Auxiliary Request 2 is unclear (Article 84 EPC). The fact that the wording of the disclaimer is literally used in Article 53(c) EPC does not change this finding.

16.8 Consequently, Auxiliary Request 2 is not allowable.

Auxiliary Requests 3 and 4

Exception to patentability (Article 53(c) EPC)

17. Although Auxiliary Requests 3 and 4 comprise only apparatus claims, they were nevertheless objected to,

on the ground that the exception under Article 53(c) EPC, in view of the process or functional features used to define the apparatus, still applied. This objection is not valid for the following reasons.

- 17.1 Article 53(c) EPC, second sentence, specifies that the provision does not apply to products, e.g. substances and compositions, for use in the methods falling under the exclusion clause. In addition to substances and compositions, the claim category "products" includes apparatus. Accordingly, the provisions of Article 53(c) EPC do not apply to apparatus claims.
- 17.2 The fact that some features of the claimed apparatus are functionally defined in relation to the body of the patient (e.g. the shunt) does not itself transform the apparatus claim into a method claim (T 712/93, Reasons. Point 3). It is true that the operation of the apparatus requires an intervention on the patient's body and involves certain steps of a surgical character (which is the case for many medical devices). This, however, does not except the claimed apparatus from patentability under Article 53(c) EPC.
- 17.3 The reasoning of T 775/97 is not applicable to the present case since the underlying situation is entirely different. The objected claim in that case related to the use of two tubes for the manufacture of a device for use in a surgical method. Since said device was assembled inside the body by a surgical method, it was found to constitute a surgical treatment (point 2.6 of the Reasons). In the present case, however, the claim is not directed to a use but to an apparatus and does not refer to any manufacturing steps.

17.4 Thus, the apparatus claims of Auxiliary Requests 3 and 4 do not fall under the exception clause of Article 53(c) EPC.

Amendments

18. Compared to Claim 9 as granted, Claim 1 of Auxiliary Requests 3 and 4 comprises the following amendments:

- (a) "... for **continuously** removing blood from a downstream location in the shunt (12) ...";
- (b) "..., and travel downstream in the shunt (12) towards the inlet (28) as an admixture with the blood flow ..."; and,
- (c) " ... to cause the removed blood admixture to contain the indicator, **as distinguishable blood characteristic at the outlet side (32) of said circulating** line ...".

18.2 Any question taken apart whether amendments a) and b) are suitable to impart clear delimitations to the apparatus claim, it is apparent from amendment c) that the indicator as such becomes the distinguishable blood characteristic at the outlet of the circulating line, i.e. what is to be measured.

18.3 This is not in line with what is stated in Claim 1 as granted, to which Claim 1 of each of Auxiliary Requests 3 and 4 was trying to refer by the amendments replacing the reference as present in Claim 9 as granted, nor with Claims 5 and 6 of Auxiliary Request 3 or Claims 4 and 5 of Auxiliary Request 4, which specify what physical property can be determined by the sensors.

18.4 In fact, the last two steps of Claim 1 as granted make clear that not the indicator but the amount of change of a selected physical property (e.g. thermal, optical, electrical impedance, ultrasound velocity, as specified in Claims 5 and 6 of Auxiliary Requests 3 and 4 and Claim 5 of Auxiliary Request 4) is actually measured.

18.5 Therefore, at least amendment c) renders amended Claim 1 unclear, and the entire set of Claims of Auxiliary Requests 3 and 4 as well, whereby the amendments are also not supported by the description (Article 84 EPC).

18.6 Auxiliary Requests 3 and 4 are not allowable.

Auxiliary Request 5

Amendments

19. Claim 1 of Auxiliary Request 5 is identical to Claim 9 as granted, in which the reference to granted Claim 1 has been recited completely. Dependent Claims 2 to 7, respectively, identically correspond to Claims 10 to 15 as granted. The formal allowability of Auxiliary Request 5 was not contested during the oral proceedings before the Board, so further details need not be given.

Novelty

20. Novelty is not contested.

Closest prior art

21. The patent in suit concerns a blood flow measurement method in haemodialysis shunts. Within the context of the present appeal, the terms "fistula", "anastomosis" and "shunt" are all used to indicate an artificially created connection between an artery and a vein of a patient in order to provide access for haemodialysis.
- 21.1 It is not contested that D3, D4 and D5, respectively concerning "a dye-dilution method for the determination of blood flow in Cimino-Brescia arteriovenous fistulae", "das reale Shuntvolumen subkutaner arteriovenöser Fisteln bei chronisch hämodialysierten Patienten" and "arteriovenous shunt measured by bolus dye dilution", concern direct determination of blood flow in a shunt. However, the opponent appellants indicated D4 and the proprietor appellants D5 as the closest prior art document. Also, the opponent appellants contended that D2 was another possible starting point, as it concerned the "non-invasive determination of recirculation in the patient on dialysis", which could be used to determine blood flow in shunts. Hence, it has to be decided which of D4, D5 and D2 discloses the closest prior art for assessing inventive step.
- 21.2 D2 (page M190, introductory first full paragraph or abstract, left column) concerns a technique (qualified as quick, inexpensive and reliable) developed to measure recirculation in a fistula, using the injection of a saline solution into the sampling port of the venous dialysis line. The saline that appears in the arterial dialysis line as a result of recirculation causes a dilution of the blood and an increase in

transmitted light intensity (the light intensity is inversely proportional to the hematocrit), which an optical detector placed across the arterial dialysis line can continuously measure using a computer collection system. The system for carrying out the method of D2 is illustrated in Figure 1 of D2, which is reproduced here below:

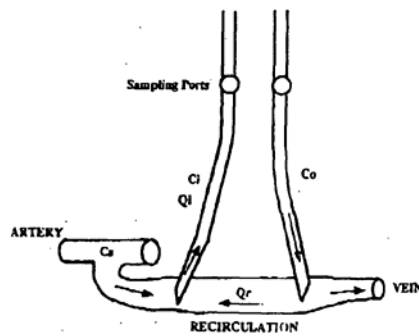

Figure 1. Standard theory and method for the determination of recirculation using blood urea nitrogen measurements.

21.2.1 The determination of D2 requires the injection of an indicator into the dialyser outflow line C_o (according to Figure 1, located downstream in the shunt) and the subsequent determination of the appearance of this indicator in the dialyser inflow line C_i (according to Figure 1, located upstream). Recirculation Q_r in Figure 1 of D2 represents the portion of blood that flows in the opposite direction to the normal blood flow within the shunt (the shunt blood flow). According to D2, a recirculation occurs when the fistula flowrate (the shunt flow) is insufficient, because of either a decrease in arterial inflow or an increase in venous resistance, hence inadequate, to support the desired dialyser blood flow. Summing up, recirculation, the undesirable counterflow of blood in a shunt arising from inadequate shunt flow, is not comparable with shunt flow, which is present even when recirculation is not present, and which is not necessarily inadequate.

21.2.2 D2 discloses an *in vitro* test, to test the system in the set-up shown in Figure 2 of D2, and an *in vivo* test on patients to carry out the recirculation measurements.

21.2.3 In the *in vitro* test, Pump B of Figure 2 of D2 was designated as the shunt flow and its delivery was adjusted so that the recirculation varied from 0-30% (page M191, right column, first three lines). Hence, the shunt flow was not the parameter to be measured.

21.2.4 In the *in vivo* test (page M191, right column last full paragraph), two sets of recirculation tests were done in each patient, whereby for each of them a comparison was made with the standard determinations based on three simultaneous measurements of blood urea nitrogen (BUN) (a classic method for determining recirculation by blood sampling), i.e. from dialyser inflow and outflow lines and from systemic sampling. In the first set the inflow and outflow lines were located as shown in Figure 1 of D2. In the second set the blood lines were reversed at the needles in order to promote a recirculation of blood (so injection of the saline and measurement of the dilution should also be reversed). The dialyser pump, the flow rate of which according to D2 influences the recirculation, was for both tests set at 350 ml/min. Hence, the second set of recirculation tests carried out with the reversed lines represents the closest embodiment of D2 to the claimed invention.

21.2.5 According to some of the conclusions of D2 (pages M192 and M193, Discussion):

- (a) the *in vivo* experiments showed that the system detects recirculation in patients on dialysis;

- (b) reversal of the dialysis lines allowed testing whether the device could determine recirculation;
- (c) recirculation could be detected using the current device when recirculation, as determined by the classic BUN method, was 16%. In one patient who normally had a 18–20% recirculation, recirculation could be detected non-invasively;
- (d) the device was thus able to detect recirculation at levels above 15%, while providing a quick, inexpensive method for determining recirculation;
- (e) saline was an innocuous suitable indicator.

21.2.6 The qualification "non-invasive" in D2 means that the determination of recirculation does not require blood sampling as in BUN method, so the patient incurs no losses of blood.

21.2.7 The author of D2 (Robert L. Hester) is also the only inventor named in patent specification US-A-5,312,550, which only concerns the device used in the first set of *in vivo* experiments of D2, i.e. without reversal of the circulating lines, as shown in the following figure:

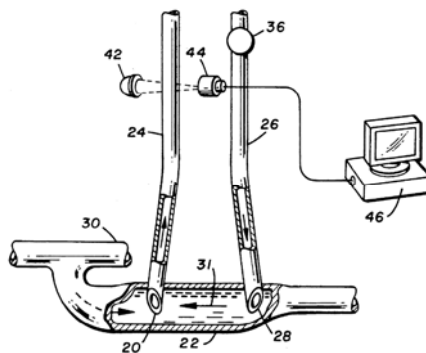

21.2.8 Thus, D2 definitely does not address measurement of shunt or access flow, let alone when no recirculation is present. Also, the device of D2 does not include all of the features of Claim 1 of Auxiliary Request 5, even

if the lines were reversed, in particular the calculating means for the shunt flow are not disclosed.

- 21.3 D3 (page 163, Paragraph bridging left and right columns) concerns a dye-dilution method for the determination of blood flow in Cimino-Brescia arteriovenous fistulae. In order to measure the flow through the shunt, 0.5 to 2.0 ml of a solution of indocyanine green was injected into an arterial catheter (percutaneously introduced into the brachial artery with the tip of the axillary artery) as a bolus. Blood was continuously aspirated from a venous catheter (percutaneously introduced into the cephalic vein with the tip in the subclavian vein) through a spectrophotometer and its density was recorded on a linear potentiometer writer, at a paper speed of 1 inch/sec. To integrate the curves, they were copied on cardboard, cut out, and weighed. The weight was compared with that of a piece of cardboard with an area of 100 square inches. A modified Stewart-Hamilton formula was used to calculate the flow:

$$BF = \frac{q \cdot D \cdot M_{100}}{M} \cdot 60$$

where BF = blood flow (ml/min), q = volume of dye injected (ml), and D = deflection (inches) on the potentiometer writer corresponding to the density of 0.1 ml of the dye solution in 10 ml of blood.

- 21.3.1 It is apparent from the above that the method of D3 requires puncturing the artery and the vein with catheters and that no circulating lines, let alone of a dialyser, are involved. Also, the means for integrating the curves are rather cumbersome, i.e. not automated.

- 21.4 D4, which acknowledges D3, concerns the determination, in 12 patients with chronic uremia, of the shunt volume

of a subcutaneous arteriovenous fistula between artery radialis and vena cephalica antebrachii and between artery femoralis and vena saphena magna, by single injection of cardio green into the fistula and registration of a dye dilution curve 15 cm proximal to the injection point, as shown in the figure of D4:



Abb. 1. Schematische Darstellung von Injektionsort (A) und Abzugstelle (B) zur Registrierung des Shuntvolumens einer Anastomose zwischen A. radialis und V. cephalica antebrachii.

21.5 The shunt flow varied between 598 and 1357 ml/min (mean value 879 ± 232 ml/min, $n = 53$). Additional venous inflow was calculated by the difference of pCO_2 between the dye injection- and withdrawal point and averaged 41 ± 29 ml/min in patients with wrist fistulas. Subtraction of venous inflow reduced the real shunt volume to 838 ± 243 ml/min. The real shunt flow of an end-to-side anastomosis between vena saphena magna and artery femoralis averaged 2045 ± 317 ml/min.

21.5.1 Compared with D3, the method of D4 still requires puncturing and catheter insertion but the determination is more automated.

21.6 According to D5 (Introduction), arteriovenous fistulae (AVF) flow rate in chronically haemodialysed patients had often been measured by methods of poor precision or high complexity (variation of cardiac output after AVF occlusion, electromagnetic flowmetry, plethysmography or Doppler effect). Still according to D5, tracer dilution had been employed, under the assumption that the thrill felt over the AVF supposed a mixer site at this level, with injection of tracer by bolus or by

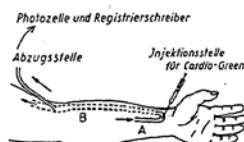
continuous infusion. However, for many reasons, the formulas of Stewart and Hamilton with tracer injected by bolus could not be employed in this kind of flow without reservations, particularly in short curves.

21.6.1 Therefore, the aim of D5 was to review the criteria of validity for this method in AVF flow, which was carried out to compare the reproducibility of the measurements with two injection tracer sites, in the artery feeding the fistula and in the efferent vessel of the fistula, this latter avoiding an arterial puncture.

21.6.2 The review study of D5 involved 28 chronically haemodialysed patients, 16 men and 12 women, ages ranging from 20 to 64 years (mean = 40), twenty-one of which had a side to end AVF, AVF being always in the arm or forearm. Under the assumption that there was a mixing chamber in the AVF, it was possible to measure the AVF flow by the Stewart and Hamilton method. A rapid injection of a bolus of 0.50–1.25 mg of cardiogreen into 0.2–0.5 ml of isotonic glucose solution was done through a plastic catheter of 10 cm length and 1 mm diameter. Blood sampling was done downstream by another catheter of the same dimensions at a constant rate of 23 ml/mm (Watson Marlow Pump 200) through a Water dichromatic cuvette X02 connected to a Water Instruments densitometer MD-41 and recorded over an X-Y table. After the first passage through the cuvette, blood was reinfused in another vein.

21.6.3 The flow was assessed by the formula

$$Q = m \int_0^{\infty} C \cdot dt$$

where Q = flow, m = amount of dye injected and integral of $C \cdot dt$ is the mathematical integration of the concentration of the tracer in the blood during its first passage.

21.6.4 The 30 measurements were divided in two groups. In the first group ($n = 14$), the tracer was injected into the afferent artery of the AVF, 10 cm upstream, and the concentration of the tracer in the blood was studied in the efferent vein, 10 cm downstream to the AVF (Figure 1). In the second group ($n = 16$), the tracer was injected into the efferent vein of the AVF, or in the upper segment of the graft linking artery and vein, with the needle going against the direction of flow. Sampling site was about 10 cm lower down in the same vessel.

21.6.5 Since the second group sampling device of D5 represents the closest embodiment to the claimed apparatus of Auxiliary request 5, Figure 2 of D5, which illustrates that device, is reproduced herein below:

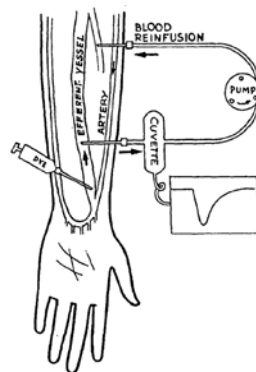

Fig. 2. Arteriovenous fistula (AVF) flow measured by Stewart and Hamilton method by dye bolus injection into the efferent vessel.

21.6.6 It is apparent from Figure 2 of D5, that the device shown, compared to those of D3 and D4, also comprises a circulating line with a pump, like that of a dialyser,

connected to already in place needles, so it comes closer to the claimed apparatus.

21.6.7 Compared to the claimed apparatus, however, it lacks injection ports in arterial and venous circulating lines, thus requiring separate injection of the bolus, and reversed lines as well.

21.7 It follows from the foregoing that D5 is more relevant than D3 and D4, and that D5 rather than D2 addresses the measurement of shunt flow, as does the patent in suit.

21.7.1 Hence, the device shown in Figure 2 of D5 represents the closest prior art for assessing inventive step.

Problem and solution

22. Over D5, in particular its Figure 2, which still requires injection of the bolus in the efferent line and which still needs puncturing the artery of the efferent line, the problem solved was seen by all the parties as the provision of an apparatus permitting a less invasive (more comfortable) performance, possibly more accurate and easier for determining the shunt flow. The Board has no reason to take a different position.

Assessment of inventive step

23. According to the results presented in Tables I and II of D5, the general shape of the dilution curves was the same whether the tracer was injected into the afferent artery or into the efferent vessel, and the increase in the dye concentration was regular with recirculation

occurring very late. Also, since D5 requires a mixing chamber, i.e. the shunt, injection of the bolus must be performed upstream to the shunt and the detector. So injection in the circulating lines is not disclosed by D5. Finally, without inverting the circulating lines, which is not suggested either by D5, the skilled person would not arrive at the claimed apparatus. Therefore, D5 does not suggest a modification of its system as defined in Claim 1 of Auxiliary Request 5.

- 23.1 D2 and D3 (*supra*) are less relevant than D5.
- 23.2 Even if D2 were retrospectively combinable with D5, the skilled person starting from Figure 2 of D5 would not get, at least, the suggestion that to avoid direct injection of the bolus in the efferent line, the system of D2 with reversed lines should be used. In fact, such system was used in D2 for promoting and measuring recirculation (not the shunt flow), and D2 does not suggest that thereby the shunt flow could be measured.
- 23.3 The remaining prior art documents are all less relevant than D5 or D2, so they need not be addressed here.
- 23.4 Therefore, the apparatus for measuring shunt flow as defined in Claim 1 of Auxiliary Request 5 was not obvious from the closest prior art D5.
- 23.5 Given the decision, the Board need not consider the secondary indicia presented by the proprietors.

Conclusions

24. One of the invoked grounds of opposition under Article 100(a) EPC (exception to patentability according to Article 53(c) EPC) prejudices the maintenance of the patent in suit as granted (Main Request) as well as in the amended form of Auxiliary Request 1. Auxiliary Requests 2 to 4 are not allowable for lack of clarity. The claims of Auxiliary Request 5 fulfil the requirements of the EPC. Therefore, Auxiliary Request 6 need not be dealt with.

Order

For these reasons it is decided that:

1. The decision under appeal is set aside.
2. The case is remitted to the department of first instance with the order to maintain the patent on the basis of the claims of Auxiliary Request 5 filed with letter dated 5 September 2011 and a description to be adapted thereto.

The Registrar:

The Chairman:

S. Fabiani

J. Riolo