

Internal distribution code:

- (A) [] Publication in OJ
(B) [] To Chairmen and Members
(C) [X] To Chairmen
(D) [] No distribution

**Datasheet for the decision
of 2 December 2009**

Case Number: T 0877/06 - 3.3.05

Application Number: 00910290.6

Publication Number: 1159052

IPC: B01D 27/08

Language of the proceedings: EN

Title of invention:
Sealing system for filter

Patentee:
DONALDSON COMPANY, INC.

Opponent:
Baldwin Filters, Inc.

Headword:
Filter Element/DONALDSON COMP

Relevant legal provisions:
-

Relevant legal provisions (EPC 1973):
EPC Art. 54, 56

Keyword:
"Inventive step (main request): yes - technical solution not derivable from the prior art"
"Double patenting (no)"

Decisions cited:
T 0013/84, T 0818/93, T 1391/07

Catchword:
-



Case Number: T 0877/06 - 3.3.05

D E C I S I O N
of the Technical Board of Appeal 3.3.05
of 2 December 2009

Appellant: DONALDSON COMPANY, INC.
(Patent Proprietor) 1400 West 94th Street
P.O. Box 1299
Minneapolis
MN 55440-1299 (US)

Representative: Eisenführ, Günther
Eisenführ, Speiser & Partner
Patentanwälte Rechtsanwälte
Postfach 10 60 78
D-28060 Bremen (DE)

Respondent: Baldwin Filters, Inc.
(Opponent) 4400 East Highway 30
Kearney
NE 68847-0610 (US)

Representative: Beck, Jürgen
HOEGER, STELLRECHT & PARTNER Patentanwälte
Uhlandstrasse 14 c
D-70182 Stuttgart (DE)

Decision under appeal: Decision of the Opposition Division of the
European Patent Office posted 13 April 2006
revoking European patent No. 1159052 pursuant
to Article 102(1) EPC (1973).

Composition of the Board:

Chairman: G. Rath
Members: H. Engl
S. Hoffmann

Summary of Facts and Submissions

I. This appeal lies against the decision of the opposition division to revoke European patent EP-B-1 159 052.

II. The opposition division relied on the following documents:

E1: JP-U-63 122 617
E1a: English translation thereof (Appendix 1)
E1b: Figure 5 of E1, enlarged (Appendix 2)
E2: WO-A-88/03 432
E3: US-A-4 498 989
E3b: Figure 14 of E3, enlarged (Appendix 3)
E5: WO-A-97/40 910
E6: JP-A-59 026 113
E7: WO-A-97/30 917
E8: JP-U-59 170 669 (Appendix 4)
E9: US-A-5 613 992

III. The opposition division held in the contested decision that the subject matter of claim 1 of the main request (claims as granted) lacked novelty having regard to documents E1 and E3. These documents disclosed a filter element arrangement comprising a filter media and a sealing system comprising a frame construction including an axially projecting extension and a **radial seal**. The first auxiliary request was not admitted into the opposition procedure, as it was filed during oral proceedings and therefore late (Rule 71a(1) EPC). Claim 1 of the second auxiliary request lacked novelty having regard to E3. The opposed patent was therefore revoked.

IV. The appeal of the patent proprietor (henceforth: the appellant) was filed with letter dated 8 June 2006 and the grounds of appeal were submitted with letter dated 17 August 2006.

V. The opponent's (respondent's) observations were received with letter dated 16 February 2007. Annexed thereto was:

Appendix 5: Webster's Third new International Dictionary, 1993, Merriam-Webster Inc., Springfield, Mass., USA, 1 page.

VI. With a letter dated 30 October 2009, the appellant submitted three sets of amended claims as a first, second and third auxiliary request, respectively. Also submitted was the following document:

Affidavit by Mr S. Gieseke, dated 30 October 2009.

VII. The respondent's reply was received with letter dated 11 November 2009 wherein objections were raised under Article 123(2) EPC against the amended claims in accordance with auxiliary requests 1, 2 and 3. Furthermore, the following documents were submitted:

E10: JP-H-01-122 817 &
E10a: English translation thereof
E11: US-A 5 415 677

VIII. Oral proceedings took place on 2 November 2009, during which the appellant submitted the document

E12: Statement of Mr G Müller of 2 December 2009

The appellant also submitted a new main request consisting of an amended claim 1 and claims 2 to 12 as granted.

IX. Said amended claim 1 in accordance with the main request reads:

"1. A filter element arrangement (50, 450) for use in an air cleaner housing (305, 672) having an internal annular sealing surface (260, 660); the filter element arrangement (50, 450) being removable and replaceable within the air cleaner housing (305, 672) upon relative axial movement between the filter element arrangement (50, 450) and the internal annular sealing surface (260, 660) of the housing (305, 672); the filter element arrangement (50, 450) comprising:

(a) a coiled media construction (125, 470) comprising a sheet of corrugations (123) secured to a bottom face sheet (132) and configured in a coil;

(i) the coiled media construction (125, 470) having: first and second ends; a first flow face (105, 471) at the first end; and a second flow face (110, 472) at the second end;

(ii) the media within said coiled media construction (125, 470) forming a plurality of flutes (124); each of the flutes (124) having a first end (146) positioned adjacent to the first flow face (105, 471) and a

second end (148) positioned adjacent to the second flow face (110, 472);

(A) a first set (136) of selected ones of the flutes (124) being open at the first end (146) and closed at the second end (148); and

(B) a second set (134) of selected ones of said flutes (124) being closed at the first end (146) and open at the second end (148);

(b) a sealing system (60, 460) including a seal member (250, 650) and a frame construction (170, 605) arranged around one of the first and second ends of the coiled media construction;

(i) the frame construction (170, 605) including an extension (174, 663) projecting axially from **and above** one of the first and second flow faces;

(A) the extension (174, 663) of the frame construction (170, 605) having an outer circumferential surface (178);

(B) the extension (174, 663) of the frame construction (170, 605) being an annular sealing support for the seal member (250, 650);

(ii) the seal member (250, 650) being positioned on, and being supported by, the extension

(174, 663) of the frame construction (170, 605);

(A) at least a portion of the seal member (250, 650) being positioned on and peripherally around the outer circumferential surface (178) of the extension (174, 663);

(B) the seal member (250, 650) including an outwardly directed, peripheral, sealing surface, the seal member peripheral sealing surface being oriented to form a releasable, peripherally directed, **radial** seal (172, 685)

between the filter element arrangement (50, 450) and a housing internal annular sealing surface (260, 660), as a result of axial insertion of the filter element arrangement (50, 450) into sealing engagement with the internal annular sealing surface of the air cleaner housing (305, 672)."

Additions to claim 1 as granted are highlighted by the board in **bold print**.

Independent claim 11 relates to a method of servicing an air cleaner including inserting a filter element as defined in claim 1. Independent claim 12 relates to a method of constructing a filter element arrangement of the type claimed in claim 1.

X. The arguments of the appellant may be summarized as follows:

(a) The appellant firstly discussed the various forms of filter element seals, namely axial seal, including axial pinch seals (according to the prior art), and radial seals (according to the opposed patent). It was argued that the frame construction according to the opposed patent comprised two elements, namely said frame and a projection or extension projecting axially from at least a portion of a flow face.

(b) *Novelty*

The opposition division had held that one of the legs of the L-shaped support ring disclosed in document E1 constituted a "projection or extension projecting axially from at least a portion of a flow face" within the meaning of the opposed patent. However, the skilled person would never address the said support ring as a frame having an extension. Said leg (even if mistaken for an extension) did not project axially from the flow face but covered a part of it. It did also not support a seal member adapted to form a peripheral seal. Due to the strong clamps (c) an axial pressure was applied to the housing leading to "bulging" and "buckling". This demonstrated the existence of high axial sealing forces, the filter element being sealed axially, not radially, within and against the housing. Therefore, novelty having regard to E1 should be acknowledged.

Document E3 (Figures 8, 9, 11, 14) showed different types of axial pinch seals. The compression ring did not generate any peripherally (radially) directed forces. Therefore this prior art, while disclosing radially directed peripheral surfaces, did not disclose that these surfaces were sealing surfaces or could be used to provide radial seals. All what was disclosed in E1 and E3 was the provision of a particular type of seal (axial seal, pinch seal) wherein the packing material in a short distance of the axial seal touched an adjacent wall. However, as explained in detail in Mr Gieseke's Affidavit, one had to distinguish between a "surface" and a "sealing surface". In particular in the case of a radial seal, a "sealing surface" must be sufficiently free from surface defects, such as voids and protrusions that would interfere with the creation and maintenance of the seal. In general, the design criteria for a radial seal were much stricter than for an axial seal.

The black spot D in Figure 10 of E3 referred to by the respondent as a seal was not disclosed or intended to form a releasable peripherally directed seal between the filter element and an internal annular sealing surface of the housing; rather, it would (at best) seem to be a seal between housing section A and outlet neck 94. One could also assume that the "*seal with the housing*" referred to in claim 9 of E3 was constituted by the black dot underneath band C. Figure 10 of E3 did also not disclose a cover.

(c) *Inventive step*

Starting from either E1 or E3 as the closest prior art, the problem underlying the opposed patent was to propose means and methods of filtering air which allowed for an optimal volume of fluted media per available housing volume, including means for protecting said media from external forces and giving the designer of air cleaners more freedom of design.

The claimed radial seal had many advantages: The seal need not be located at the point where separation of the housing parts occurred. Since the seal was supported on a frame arrangement, compression forces were not directed into the media pack, thus avoiding damage.

Document E1 disclosed an axial seal in which the radial forces were partly neutralized by the increased buckling strength of the filter media. This was diametrically opposed to the claimed invention and did not prompt the skilled person to arrive at the claimed solution. Likewise, nothing was disclosed in E3 pointing towards the claimed teaching. Even if the skilled person would replace the pinch seal of E3 with the lip seal of E6 or the radial seal of E9, the result would still be different from the solution claimed in the opposed patent.

XI. The arguments of the respondent may be summarized as follows:

- (a) Document E1 disclosed a removable coiled filter element with a plurality of flutes for use in an air cleaner housing. The primary issue of dispute was claims feature 1.4 (b) (the frame and the seal system). Figure 5 of E1 disclosed a frame construction of L-shaped cross-section extending around one of the ends of the coiled media construction, said frame having a first and a second leg. One of the legs was projecting axially from one of the first and second flow faces and therefore constituted an extension within the sense of claim 1 of the opposed patent. Said extension provided support for an annular sealing member forming a releasable peripherally directed seal between the filter element and the housing. Therefore, the subject matter of claim 1 of the opposed patent lacked novelty over E1.
- (b) Figure 14 of E3 showed a seal member 116 sealing against the side of the housing (page 9, lines 21 to 23). The sealing system included a frame construction arranged around one end of the coiled media, said frame construction comprising an extension (#174) projecting axially from the flow surface. In addition, the seal member was positioned on and supported by the extension of the frame construction. Hence all the features of claim 1 were anticipated by E3 (Figure 14). Likewise, Figure 10 of E3 disclosed a filter system and a housing having a sealing member and a

frame construction as claimed in the opposed patent.

- (c) The claimed subject matter was at least obvious having regard to E4, disclosing a coiled filter media construction with a radial sealing surface which when introduced into an appropriate housing would provide a peripheral sealing surface.
- (d) Document E7 disclosed a sealing system concept to which anyone skilled in the art would add the concept of feature 1.4(b) known, for example, from E1, E2 and E6.
- (e) Document E10 (E10a) disclosed a fluid filtering device (an air cleaner arrangement) having a filter element in a housing wherein a pure radial seal is formed between the housing and the filter element. The filter element consisted of a honeycomb structure having parallel tubular passages alternately closed at their ends. They thus corresponded to the coiled media construction of the opposed patent. Furthermore a sealing system was disclosed including a seal member (9a in Figure 1) and a frame construction (5), the latter including an extension having an outer circumferential surface. The extension projected axially from one of the first or second flow faces of the honeycomb element and provided an annular sealing support for the seal member. As the seal member in turn had an outwardly directed peripheral sealing surface providing a radial seal to the housing as a result of the axial insertion of the filter element arrangement into sealing

engagement with the annular sealing surface of the cleaner housing, all the features of claim 1 of the first auxiliary request were anticipated by E10. E10 also showed a first compartment having an annular internal sealing surface and an outlet region to allow air to flow out of the air cleaner housing, thereby also anticipating the subject matter of claim 1 of the second auxiliary request.

The subject matter of claim 1 of the third auxiliary request differed from E10 only by claim feature (b)(ii)(C) which was, however, obvious for the skilled person and moreover known from E9 (col. 5, line 65 to col. 6, line 5).

- (f) E11 related to air filters in general. Said document discussed at column 1, lines 40 to 55, a clear tendency in the art toward the use of radially sealed filters. Figures 1 and 2 of E11 disclosed two types of radial seals provided by gaskets 60 and 62. Therefore, the teaching of E11, when combined with one of E1 to E3 as far as the housing of the coiled media construction was concerned, rendered the subject matter of claim 1 of all the auxiliary requests obvious.

- (g) The Affidavit submitted by the appellant did not address the claim features, but referred to a plurality of features not forming part of granted claim 1 which could not, therefore, be taken into consideration.

- (h) Possible double patenting with respect to granted European patent EP 1 795 246, in the name of the appellant, should also be investigated.

XII. Requests

The appellant requested that the decision under appeal be set aside and the patent be maintained on the basis of the set of claims comprising claim 1 of the main request submitted during the oral proceedings and claims 2 to 12 as granted or, in the alternative, according to one of the first and second auxiliary requests submitted with letter of 30 October 2009 or the third auxiliary request submitted during the oral proceedings.

The respondent requested that the appeal be dismissed.

Reasons for the Decision

1. *Amendments (Article 123(2) and (3) EPC; main request)*

No objection under Article 100(c) EPC was raised in opposition proceedings against the wording of the claims as granted which are fairly based on the original disclosure. In particular, the expression "extension" appearing in claim 1 was already present in the granted version of the claims. The board considers that it is clear in the context of the application as a whole that the terms "extension" and "projection 174", the latter being used in the description to designate item 174 of the figures, in fact relate to the same part, namely the upper part of the frame construction

170 that "*projects or extends from at least a portion of one of the first and second flow faces 105, 100 of the filter construction 100*" (page 8, lines 24 to 28). Therefore, the respondent's objection under Article 123(2) EPC against the claim terminology is not convincing.

The new feature "*[from] and above*" inserted into item (b)(i) of granted claim 1 is based on the description, page 8, line 24 to page 9, line 3, of the original application documents published as WO-A-00/50149. It is clear from the context of the cited passage, in particular in view of the expression "*one of the first and second flow faces 105, 110*", that the extension or projection 174 may extend from and above either the first or the second flow face.

The term "*radial*" inserted in item (b)(ii)(B) of granted claim 1 is disclosed throughout the description, for example on page 9, lines 15 to 17; page 11, lines 25 to 31; page 12, lines 21 to 23; and page 19, lines 18 to 20, in connection with the seal.

2. *Article 84 EPC*

The respondent argued that the expression "*radial seal*" was not clear in the context of the claims as long as said seal was not defined as being compressible.

The board however considers that the skilled person implicitly understands that the seal member is to a certain extent compressible. Reference is made to the description of the opposed patent, which frequently refers to a "*compressible seal member 250*" and in

particular to paragraphs [0039] and [0042], disclosing the preferred amounts of compression of such a seal member, and to paragraphs [0087] to [0090], discussing suitable materials, such as foamed polyurethane. It is therefore in the board's opinion not necessary to explicitly state in the claim that the seal be compressible.

3. *Novelty (main request)*

- 3.1 Document **E1 (E1a)** discloses in Figure 5 a filter element of coiled, fluted filter media as claimed having frame constructions (steel support rings 6) at both ends thereof. The support rings are L-shaped; thus one leg thereof may be called a frame construction having a projection or extension.

At the downstream side of the filter element said extension of the L-shaped support ring 6 carries a plastic pack 7 which forms a peripheral seal with the container (a) housing the filter due to the compressive force exerted by clamps (c).

The appellant repeatedly asserted that E1 only disclosed an axial seal. However, according to Figure 5, a part of the sealing structure (support ring 6 and packing 7) also extends axially, along the filter element's side surface. This axially extending part of the packing 7 could be seen as providing a radial seal against the inner circumferential surface of the housing, see the details from the figures:

E1, Fig 5:

Detail from Figure 5:

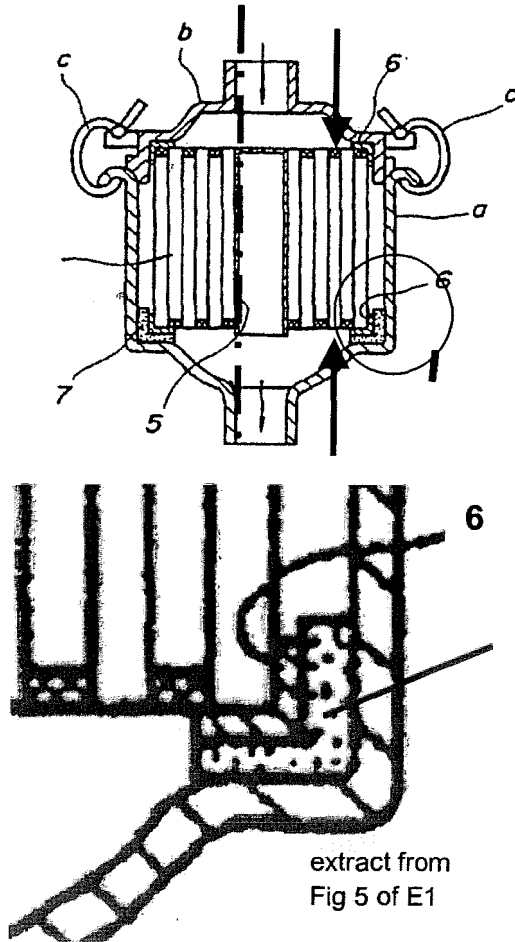

On the other hand, it is evident that sealing forces exerted by clamps (c) only act in an axial direction. The board has therefore doubts whether the axially extending part of plastic packing (7) de facto forms a radial seal, or is merely intended to prevent sideward (radial) movements or vibrations of the filter element (e).

This question needs not be decided, however, because the relevant axially projecting parts of the sealing system of E1, namely supporting frame 6 (and seal member 7), do not project **from and above** one of the first and second flow faces, as required by item (b)(i)

of claim 1 in accordance with the main request. The board accepts in this context the definition of the term "flow face" given by the appellant as the region in which air enters (or exits) the filter media construction at its first or second ends. According to said definition, the flow face of a filter media corresponds to the surface delimited by the (circular or elliptical, as the case may be in a coiled media construction) outer circumference of the filter media. In contrast, the flow face **does not extend beyond** said area of air entry or exit, respectively. No argument was submitted that anyone skilled in the art will understand said term "*flow face*" differently.

Having this in mind, both the L-shaped frame and the axially extending seal shown in Figure 5 of E1 are not extending axially **from and above**, but **adjacent or next to** a flow face.

Therefore, the subject matter of claim 1 is novel having regard to E1 (E1a).

- 3.2 Document **E3** discloses a spirally coiled filter media comprising a plurality of flutes, alternating ends of the flutes being closed at the upstream and downstream ends, respectively, of the filter. The filter media may be inserted into the inlet end of a cleaner housing where it is held in place by a compression ring and a gasket. Alternatively, as shown in Figures 13 and 14, the filter media element 102 includes a downstream gasket 116 sealing it against the housing 104. See claims 1 to 3; Figures 3, 4, 5, 9, 10 and 14; page 8, lines 14 to 18; page 9, lines 14 to 23.

Figure 14:

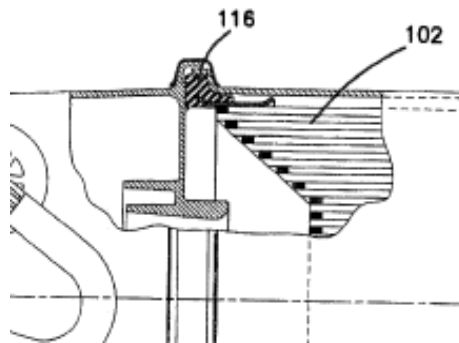

According to the respondent, Figure 14 also shows a frame construction (designated as #170 in Appendix 3 (E3b)) including an extension (#174) projecting axially from the flow surface of the coiled media construction. The outer circumferential surface and the extension of the frame construction forms an annular sealing support for the seal member 116, thereby anticipating claim features (b)(i) and (ii). Upon insertion of the filter media in the housing, the seal member's peripheral sealing surface comes into **sealing engagement** with the internal annular sealing surface of the housing 104.

The embodiment of Figure 10 of E3 shows, according to the respondent, a sealing system including a seal member and a frame construction. However, in this embodiment, the "frame" belongs to the housing 78, not to the sealing system.

According to the appellant, E3 discloses an **axial pinch** seal (the seal member being "pinched" between the parts of the housing upon exertion of an axial force).

The board considers that upon exertion of an axial force, the seal may not only be compressed axially, but also may expand radially (the sealing forces at least

partly being deflected in an axial direction) until contacting the housing's inner surface, so as to possibly form a radial seal. However, further considerations of this point are unnecessary since E3 in any case fails to disclose a frame construction including an extension projecting axially **from and above** one of the first and second flow faces. As seen most clearly in Figure 14 of E3, the frame construction supporting downstream gasket 116 projects axially **adjacent or next to** the flow face of filter media 102, but not axially **above** it.

Therefore, the subject matter of claim 1 is novel having regard to E3.

- 3.3 Document **E10 (E10a)** discloses a filter unit for an air cleaner used in connection with internal combustion engines. As shown in Figures 1 and 2, the filter unit has a honeycomb structure consisting of a plurality of parallel tubular passages of filter material closed at alternate ends. A cylindrical casing accommodates the filtering element and has at its ends attachment rings 4 and 5 having threads for connection to the inlet and outlet ducts. Also shown are seal packings 17a and 19a, but their precise location is not clearly visible from the drawings. In any case, there is no frame construction as claimed and the filter is not a coiled filter media construction.

Therefore, novelty having regard to E10 must be acknowledged.

- 3.4 Document **E8 (E8a)** discloses an air cleaner (1) for an internal combustion engine which comprises a two-part

housing consisting of a casing (2) and a cover (3), and a removable, coiled filter media (4). A radial seal (consisting of packings (12) and (13)) is provided between the filter media and the housing.

See Figure 1:

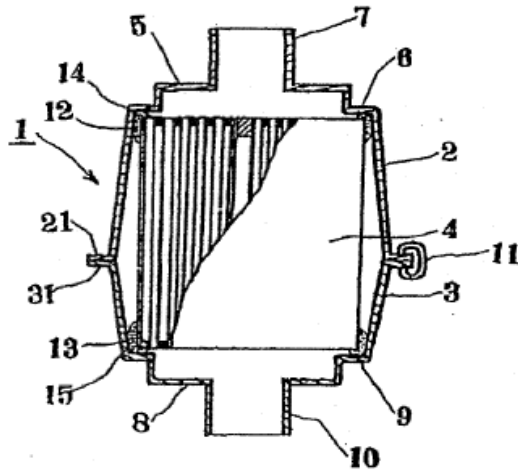

Figure 1

However, there is no frame construction supporting said seal packings.

3.5 Document **E11** refers to air filters in general. Figures 1 and 2 disclose two types of radial seals (gaskets 60 and 62) between a filter housing and two filter elements 16 and 18, respectively. In particular, gasket 60 is supported by metal end cap 100. However, said supporting metal end cap is not projecting axially from and above the flow face of the filter.

In another embodiment depicted in Figures 7 and 8, axial gasket 200 supported by metal end cap 200 forms a radial seal between filter housing 208 and filter construction 16 (column 5, lines 6 to 25). In this embodiment, too, the supporting structure is adjacent to, not above, the flow face.

Therefore, at least claim feature (b)(i) is not disclosed in E11.

3.6 **E6** discloses a filter assembly wherein the filter element has a ring-shaped sealing protrusion at the outer periphery of a supporting plate. Said protrusion seals the filter element against the inner surface of the cap of a two-part filter housing, forming a radial lip seal (see Figures 4, 6, 9a and 9b). The support plate is clearly distinguished from the frame construction according to the opposed patent in that it does not feature an extension projecting axially from and above the flow face of the filter element.

3.7 No other documents have been cited as relevant for novelty. The board is also satisfied that none of the remaining prior art documents discloses all of the claim features in combination.

Claim 1 of the main request thus satisfies the requirements of Article 54(1)(2) EPC. Claims 2 to 12 of the main request derive their novelty by way of back-reference to claim 1.

4. Inventive step

The patent in suit relates to a filter arrangement for use in an air cleaner housing, comprising a coiled media construction and a sealing system.

4.1 *Closest prior art*

The closest prior art is normally a prior art document disclosing subject-matter conceived for the same

purpose or aiming at the same objective as the claimed invention and having the most relevant technical features in common.

Document E1 reveals all the features of claim 1 in accordance with the main request except for claim item (b)(i) (see point 3.1). The parties have identified E1 as the document representing the closest prior art. The board concurs in choosing document E1 as the starting point for assessing inventive step.

4.2 *Technical problem*

4.2.1 The objective of the patent in suit is the removal of particulate material from an air flow upstream of e.g. an engine, a turbine or a furnace (*cf.* paragraph [0002] of the opposed patent).

4.2.2 The appellant defined the problem underlying the opposed patent as proposing means and methods of filtering air which allowed for an optimal volume of fluted media per available housing volume, protected said media from external forces and allowed the designer of air cleaners more freedom of design (statement of grounds for appeal, page 30).

The respondent agreed with this formulation of the technical problem.

4.2.3 Document E1 is concerned with the technical problem of avoiding the bulging of the filter media which is caused by the pressure applied to its periphery by the housing and the seal upon fastening of the cover (see E1a, page 4, second paragraph). Compared with this

closest prior art, the technical problem of protecting the filter media from external forces, although not explicitly stated in the opposed patent, becomes immediately apparent. Said part of the technical problem is deducible from the application as filed taking into account the features described in the figures and the effects and advantages clearly associated with them. The reformulation of the technical problem is therefore allowed, in line with the principle laid down in decision T 818/93 (of 2 April 1996; Reasons 5.2, fourth paragraph).

The optimization of the volume of fluted media per available housing volume is, in the board's view, a technical problem which the skilled person always takes into consideration because of the space restrictions prevailing in the places where such filter arrangements are used (generally engines of vehicles, buses, trucks, boats etc; see paragraph [0070] of the opposed patent). Therefore, said part of the technical problem is taken into account, even if it is not explicitly mentioned as such in the application as filed.

- 4.2.4 However, the board observes that the part of the above defined technical problem relating to the "freedom of design" is not addressed in the application documents as filed. In this respect, it was stated in T 13/84 (OJ EPO 1986, 253; see Reasons, point 11) that a reformulation of the technical problem was not precluded by Article 123(2) EPC if the problem could be deduced by the skilled person from the application documents as filed when considered in the light of the closest prior art. It follows that reformulation of a problem is prohibited if the problem so modified is

neither disclosed in the originally filed application itself nor deducible when the application is considered in the light of the closest prior art. Hence, having regard to the fact that E1 (or, for that matter E3) does not address such a design problem either, the board concludes that the part of the technical problem relating to the "freedom of design" aspect cannot be deduced from a comparison of the opposed patent with the closest prior art. Said part of the technical problem is, therefore, not taken into consideration for the assessment of inventive step.

4.2.5 Therefore, the board concludes that the problem underlying the patent in suit in the light of document E1 is to protect the filter media from external forces and to optimize the volume of fluted media per available housing volume.

4.3 *Solution*

As a solution to the technical problem defined under point 4.2.4, the opposed patent proposes a filter element arrangement according to claim 1, characterized in that said filter element arrangement comprises:

- a **frame construction** (170, 605) including an extension (174, 663) **projecting axially from and above one of the first and second flow faces;**
- the extension (174, 663) of the frame construction (170, 605) being an annular sealing support for the seal member (250, 650);
- the **seal member** (250, 650) **being positioned on and being supported by the extension** (174, 663) of the frame construction (170, 605);

- the seal member forming a **radial seal** between the filter element arrangement and the internal sealing surface of the housing.

4.3.1 The respondent disputed that the problem of volume optimization has been solved. More specifically, it argued that no gain in volume available for the filter media has been achieved.

The board however considers that the claimed radial seal arrangement, positioned on the frame construction's extension axially from and above one of the first and second flow faces, indeed allows increasing the volume available for the filter media, compared with an axial seal construction. This may be in particular seen from a comparison of E1, Figure 5, and the opposed patent, Figure 9. Firstly, by shifting the seal according to the opposed patent to a position above the filter media's flow face, the exploitation of the outer circumferential gap in E1 between the filter media and the housing is improved. Secondly, one notices that in the claimed arrangement - due to the supporting frame construction - the sealing forces do not act on the filter media, in contrast to the case of an axially sealed filter media arrangement as shown in E1 (and E3).

The board is therefore satisfied that the technical problem as identified under point 4.2.5 above has been successfully solved.

4.4 It remains to be decided whether or not the claimed solution is obvious in view of the prior art.

4.4.1 The respondent argued that the skilled person, starting from E1 would recognise that the problem of buckling of the filter media could be solved by providing a radial seal instead of an axial seal. To do so was - according to the respondent - clearly suggested by the following passage of E11 (column 1, lines 40 to 46):

"Axial compression techniques for sealing require filters and filter housings which are constructed so as not to collapse under compression. Since axially compressed filters tend to be more expensive than radially compressed filters because they are subjected to higher axial loads, radially sealed filters are being increasingly used. Since filter housings for both axially and radially sealed filter elements are on existing vehicles and equipment, confusion can occur as to which filter element should be used as a replacement when the original or prior replacement filter element is changed."

The respondent also pointed to E8 (E8a) (Figures 1 and 3), disclosing a **radial** seal between an air cleaner housing and a removable, coiled filter media construction. In such a construction, it would be an easy step for someone skilled in the art to add a frame construction as disclosed in documents E1, E2 or E6.

4.4.2 In the board's view, these arguments are insufficient to deny the presence of an inventive step.

To be sure, radial seals are disclosed in E8 and suggested by E11. The provision of such a radial seal would evidently overcome the problem addressed in E1,

namely of buckling of the filter media in axial direction.

However, in the absence of a frame construction supporting said radial seal, the problem of crunching the filter media in radial direction persisted, unless the sealing forces are substantially reduced. Such a substantial reduction of sealing forces entails the danger of inefficient sealing and possible leakage, and is therefore disadvantageous.

Moreover, the combination of E1 and E8 (or E11) still does not lead to the invention as claimed, because neither of these documents discloses a filter arrangement wherein the frame construction has an extension that projects axially from and above one of the first or second flow faces of the filter media. In this manner the seal member, supported by the said extension, is moved from its position in E1 and E8 along the side of the housing to a position upstream or downstream the filter media, making available the space between housing and filter media. The prior art does not suggest such a position of the seal member in order to solve the technical problem of optimizing the volume available of fluted media within the housing.

Essentially the same arguments apply to a hypothetical combination of E8 and E6 (or E2).

- 4.4.3 No other conclusion would be reached starting from E3 as the closest prior art. Even if the skilled person decided to opt for a radial seal as a solution to the above mentioned technical problem, for the reasons set out for instance in E11, there is still no incentive in

any prior art document to support this radial seal structure on a frame extension which is not adjacent to the filter media, but extends from and above one of the media's flow faces.

4.4.4 The respondent also argued a lack of inventive step having regard to document E4. Said document discloses a fluid cleaner system consisting of a housing (6, 7) and a cylindrical filter element (50). A sealing system including a seal member 3 and a frame construction 2 is arranged at the second end (50b) of the filter media (50). The seal member (3) sits on an end tip (2b) of the said frame and seals the two housing parts (6,7), forming an **axial pinch** seal (see Figures 6 and 14). There is no reason apparent to the board why the skilled person should thoroughly alter the design of E4, thereby replacing an axial pinch seal by a radial seal and modifying the frame extension and seal position, so as to arrive to the claimed subject matter.

4.4.5 Document E5 reveals various embodiments of a filter apparatus including a coiled, fluted filter element in a cylindrical housing having a first open and a second closed end (page 3, lines 9 to 18; Figures 8 and 9).

Figure 9 shows an alternate embodiment of the filter apparatus (100A) also including a filter element 102A and a housing 104, wherein gasket 118 forms an **axial** seal between the mounting member 116 and a fitting. This embodiment is clearly remote from the subject matter claimed in the opposed patent.

Figure 8 shows a filter apparatus 100 including a pleated, rolled filter element 102 inside a filter

housing 104. The rolled filter element 102 has an end cap 110 mounted thereon and a gasket 108 forming a **radial** seal between the end cap and the annular centre divider segment 124 of a mounting element 116. In the respondent's argument, the person skilled in the art would alter the frame construction so as to press seal 108 outwardly, thereby creating a radially outwardly directed seal. However, no convincing arguments have been submitted as to why the skilled person should do so, in view of the problem posed, so that the respondent's argument cannot succeed.

4.4.6 Document E2 relates to a liquid filter apparatus 10 having an integral filter unit 40. The integral filter unit has a bottom and top end caps (42, 56) with a core tube (50) and a concentric outer tube (54) extending between the end caps. The bottom end cap (42) has an axial extension and O-rings (48) sealing against the inner surfaces of an aperture in the base plate providing the inlet opening for the fluid (see Figure 1). The filter action is by radial flow through the filter material.

Being designed as a liquid filter, the filter action in E2 is different from the action required according to the opposed patent. E2 does not relate to sealing filter elements being sealed against the inner surfaces of the housing. Therefore, E2 cannot render the claimed subject matter obvious, either alone or taken in combination with one or more other citations.

4.4.7 Document E7 (see in particular Figures 7 and 8; page 10, lines 11 to 27; page 11, lines 9 to 21) reveals a spiral filter apparatus 60 inserting into a duct 64

connecting to a housing 62. The filter housing 62 has a substantially widened diameter relative to the duct for receiving a cylindrical filter element 52 having a larger flow receiving face than the cross-sectional area of the duct 64. The filter housing 62 includes a skin or other outer protective layer or housing portion 66 and transitional portions 68. The housing 62 connects to the duct through clip connectors 70. Gaskets 73 provide an air- and/or liquid-tight seal between the outer portion 66 of the filter housing 62 and the transitional members of the housing 68.

According to E7, the sealing system (gaskets 73) do not form part of the filter, but of the housing (clips 70). The document also fails to disclose a frame construction having an extension as claimed. The board therefore considers that E7 cannot, alone or in combination, render the claimed subject matter obvious.

- 4.5 The filter arrangement disclosed in E9 does not comprise a coiled filter media construction. Filter media 25 is positioned between inner support 26 and outer support 27 and consists of pleated paper. It carries end caps 23, 24, having outer annular compressible portions sealing radially against support 27 and base 63 (Figures 3 to 6; column 2, lines 28 to 38). Even if one equated - which the appellant denies - support 27 with the frame construction of the opposed patent, said support 27 does not extend from and above a flow face of the filter media. The board notes that in E9 the end cap 24 is closed, except for a draining aperture, so that there is no flow face on this side of the filter media (column 5, lines 26 to 28).

Therefore, a combination of E9 with E1 or E2, on which the respondent also relied in its written submissions, does not render the claimed subject matter obvious.

- 4.6 For these reasons, the subject matter of claim 1 in accordance with the main request involves an inventive step, as required by Article 56 EPC.

Dependent claims 2 to 10 and independent method claims 11 and 12 recite - by way of back-reference - all the features of claim 1 and thus derive their patentability from said claim.

The claims in accordance with the main request thus satisfy the requirements of Article 56 EPC.

- 4.7 Since the main request is allowable, there is no need to deal with the subsequent requests.

5. *Double patenting*

- 5.1 The objection of possible double patenting was raised by the respondent with respect to the auxiliary requests submitted by the appellant with letter of 30 October 2009. In this regard, the respondent drew in particular attention to divisional application EP 1 795 246, in the name of the appellant.

- 5.2 Granted claim 1 of said European patent EP-B-1 795 246, which stems from a divisional application of the application underlying the patent in suit, is directed to an **air cleaner** including a housing having a housing compartment and a removable cover and further comprising a removable and replaceable filter element

arrangement positioned in the air cleaner housing comprising a coiled media construction, a seal member and a frame arranged around one of the first and second ends of the coiled media construction; **the frame having a depending lip**, further including a projection having a **tip portion** projecting axially from one of the first and second flow faces, and including **a step providing a transition area between the cross-sectional width of the depending lip and the smaller cross-sectional width of the tip portion**; the **tip portion** of the frame having an outer circumferential surface; the **tip portion** of the frame **being an annular sealing support for the seal member**; the seal member being positioned on, and being supported by, the tip portion of the frame (highlighting by the board).

The subject matter claimed in claim 1 of said European patent EP-B-1 795 246 thus differs from the subject matter in accordance with claim 1 of the main request of the patent under appeal firstly in that it relates to an air cleaner, and not to a filter element arrangement; and secondly, as regards the filter arrangement which forms part of the said air cleaner, at least by the claim features highlighted above.

- 5.3 In decision T 1391/07 (of 7 November 2008; Reasons, points 2.6 and 2.7), the board saw no basis for extending the practice of prohibition of "double patenting" to cover claims not defining the same subject-matter but conferring a scope of protection overlapping with each other only partially in the sense that some, but not all of the embodiments notionally encompassed by one of the claims would also be encompassed by the other one of the claims. The lack of

legitimate interest of an applicant in obtaining two patents for the same subject-matter - as invoked by the Enlarged Board of Appeal in decisions G 1/05 and G 1/06 - could not be invoked when the scopes of protection conferred by the respective subject-matters **overlap only partially** with each other as there was no manifest objective reason to deny the legitimate interest of the applicant in obtaining a protection different from - although partially overlapping with - that of the parent patent already granted. Accordingly, the board concluded that the mere fact that the scope of protection notionally conferred by the claim in suit would partially overlap with that of the granted parent patent did not prejudice the grant of a patent.

- 5.4 In view of the substantial differences identified under point 5.2 above resulting in, if at all, only a partial overlap in the respective scopes of protection conferred by EP-B-1 795 246 and the opposed patent, the board concludes that no issue of double patenting arises with respect to the claims of the main request.

Order

For these reasons it is decided that:

1. The decision under appeal is set aside.

2. The case is remitted to the department of first instance with the order to maintain the patent in amended form according to the set of claims comprising claim 1 of the main request submitted during the oral proceedings and claims 2 to 12 of the patent as granted and a description and the figures to be adapted.

The Registrar

The Chairman

C. Vodz

G. Rath